

CoMatic:

Ready to Roll

貝特機械股份有限公司
CO-MATIC MACHINERY CO., LTD.

台灣 台中市后里區三壽路473-16號 42156
No. 473-16, San Feng Road, Houli, Taichung, Taiwan 42156
Tel: +886 4 2556 7105 : co-matic@co-matic.com

廣特機械工業(廣州)有限公司
PRO-MATIC MACHINERY(GUANGZHOU) CO., LTD.

廣州市番禺區沙灣鎮南成路1號 511483
No. 1, Qing Feng Road, Shawan, Panyu Dist., Guangzhou, China 511483
Tel: +86 20 3483 1189-99



CoMatic:

30

EASY FEEDER

It's Time to Change



www.co-matic.com



www.co-matic.com

Specifications Subject to Change without prior notice



Multinational Patents

EASY FEEDER



Instant 90 Degree Swivel Adjustment
Memo-Positioning : 90° Auto Lock

> Interchangeable Roller

Digital Control Panel
Variable Speed 2-22M/ min
Lubricant Gauge
Easy Flip Handle



> Cutting Edge Innovation – DC Brushless Servo Motor
High Efficient – More Power, More Torque
Environmental Friendly – Save over 50% power output than same size power feeders
Cost Saving – Continuously earning back cost from the energy saved annually.



> Inclinable Feeding Adjustment Indicator



> Inclined Feeding

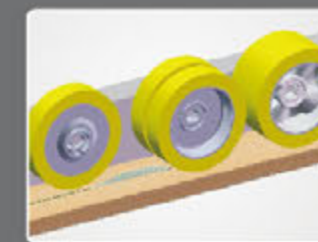

> Detachable Inner Roller Prevent Possible Blade Damage to the Work Piece



> Detachable Outer Roller Allows Extra Space for Router

EASY FEEDER

DC30 >



DC40 >



> **GR121 ROLLER**
(120Dia. x 60 mm W.)
Standard Roller



> **RU21 Separated Roller**
(120Dia. x 25 mm W.)
Optional



> **SL02 Swivel Kit**
Interchangeable (Optional)

	Voltage	Roller size	Roller	Feeding speed	Max. power output	Horsepower	Packing size	Net Weight	Gross Weight	Machine Body	Body + Stand
DC30	100-120V/1 Phase, 200-240V/1 or 3 Phase 380-420V / 3 PHASE	Φ120 x 60 mm / Φ120 x 25 mm	3	2-22 M/min (7-72 FPM)	400 W	1/2 HP	Body : 588 x 326 x 306 mm (23" x 12-3/4" x 12") Stand: 770 x 320 x 290 mm (30-3/8" x 12-5/8" x 11-1/2")	23 kg (51 Lb) 30 kg (66 Lb)	25 kg (55 Lb) 32 kg (72 Lb)	490 Sets / 20ft Container	224 Sets / 20ft Container
DC40	100-120V/1 Phase, 200-240V/1 or 3 Phase 380-420V / 3 PHASE	Φ120 x 60 mm / Φ120 x 25 mm	4	2-22 M/min (7-72 FPM)	400 W	1/2 HP	Body : 685 x 326 x 316 mm (27" x 12-3/4" x 12-3/8") Stand: 770 x 320 x 290 mm (30-3/8" x 12-5/8" x 11-1/2")	26 kg (57 Lb) 30 kg (66 Lb)	28 kg (62 Lb) 32 kg (72 Lb)	392 Sets / 20ft Container	205 Sets / 20ft Container

LIGHT DUTY

M3



BABY FEEDER

Small, Lightweight, Economical and Versatile.
Patented 3-D Adjustable.

AF32



JUNIOR FEEDER

MEDIUM DUTY

AF308



CABINET FEEDER

Ideal for Cabinet Works & Combining Machine.

AF04



TRACK FEEDER

Special for Shorter Piece or Extra Heavy-Duty Work.

Model	M3	AF32
Horsepower / Rotation	1/8 HP (0.094 KW), 1 phase only; Forward / Reverse	1/4 HP (0.188 KW), 1 or 3 phase ; Forward / Reverse
Range of Speeds (50Hz)/(60Hz)	2-12 M/min (6.5-40 FPM)	50HZ: 5/6.5/8/11 M/min (16/21/26/36 FPM) 60HZ: 6/8/10/13 M/min (20/26/33/43 FPM)
Rollers (Belts)	Φ76 x 30 mm x 3 pcs (Φ3" x 1-3/16" x 3 pcs) / PU	Φ80 x 30 mm x 3 pcs (Φ3-1/8" x 1-3/16" x 3 pcs) / Synthetic Rubber
Roller Suspension	8.3 mm (5/16")	18 mm (3/4")
Net Weight	10.5 Kg (23 Lb)	33 Kg (73 Lb)
Gross Weight	12 Kg (26 Lb)	35 Kg (77 Lb)
Carton for Body	560 x 280 x 230 mm (22" x 11" x 9")	580 x 580 x 280 mm (22-7/8" x 22-7/8" x 11")
20' Container Loading	840 Sets (840 Cartons)	320 Sets (320 Cartons)

Model	AF308	AF04
Horsepower / Rotation	1/2 HP (0.375 KW), 1 or 3 phase ; Forward / Reverse	1 HP (0.75 KW), 1 or 3 phase ; Forward / Reverse
Range of Speeds (50Hz)/(60Hz)	3 PH : 3/4.5/6/7.5/9/11.5/15/23 M/min ; 1 PH : 3/4.5/7.5/11.5 M/min (3 PH : 9.5/15/19/25/30/38/50/76 FPM ; 1 PH : 9.5/15/25/38 FPM)	4/8/10/20 M/min (13/26/33/66 FPM) 4/8/10/20 M/min (13/26/33/66 FPM)
Rollers (Belts)	Φ100 x 50 mm x 3 pcs (Φ4" x 2" x 3 pcs) / Synthetic Rubber	1118 x 12.7 mm x 3 pcs (44" x 1/2" x 3 pcs) / Synthetic Rubber
Roller Suspension	24 mm (15/16")	20 mm (3/4")
Net Weight	25 + 20 Kg (55 + 44 Lb)	30 + 34 Kg (66 + 75 Lb)
Gross Weight	27 + 22 Kg (59 + 49 Lb)	32 + 36 Kg (70 + 79 Lb)
Carton for Body	520 x 470 x 260 mm (20-1/2" x 18-1/2" x 10-1/4")	770 x 560 x 290 mm (30-3/8" x 22" x 11-1/2")
Carton for Stand	770 x 230 x 260 mm (30-3/8" x 9" x 10-1/4")	770 x 320 x 290 mm (30-3/8" x 12-5/8" x 11-1/2")
20' Container Loading	276 Sets (552 Cartons)	150 Sets (300 Cartons)

HEAVY DUTY

AF34



STOCK FEEDER
3 Rollers, 4 Speeds

AF44



STOCK FEEDER
4 Rollers, 4 Speeds

AF38



STOCK FEEDER
3 Rollers, 8 Speeds

AF48



STOCK FEEDER
4 Rollers, 8 Speeds

Model	AF34	AF44	Model	AF38	AF48
Horsepower / Rotation	1 HP (0.75 KW), 1 or 3 phase ; Forward / Reverse	1 HP (0.75 KW), 1 or 3 phase ; Forward / Reverse	Horsepower / Rotation	1 HP (0.75 KW), 1 or 3 phase ; Forward / Reverse	1 HP (0.75 KW), 1 or 3 phase ; Forward / Reverse
Range of Speeds (50Hz)/(60Hz)	4/8/10/20 M/min (13/26/33/66 FPM)	4/8/10/20 M/min (13/26/33/66 FPM)	Range of Speeds (50Hz)/(60Hz)	2/4/5.5/7/11/13/16.5/33 M/min (6.5/13/18/22/36/43/55/108 FPM)	2/4/5.5/7/11/13/16.5/33 M/min (6.5/13/18/22/36/43/55/108 FPM)
Optional Speeds (w/extra gear set)	3/6/13/26 M/min (10/20/43/85 FPM)	3/6/13/26 M/min (10/20/43/85 FPM)	Optional Speeds (w/extra gear set)	1.5/3/5/7/9.5/13/21/41 M/min (5/9.5/15/23/31/42/69/134 FPM)	1.5/3/5/7/9.5/13/21/41 M/min (5/9.5/15/23/31/42/69/134 FPM)
Rollers (Belts)	Φ120 x 60 mm x 3 pcs (Φ4-3/4" x 2-3/8" x 3 pcs) / Synthetic Rubber	Φ120 x 60 mm x 4 pcs (Φ4-3/4" x 2-3/8" x 4 pcs) / Synthetic Rubber	Rollers (Belts)	Φ120 x 60 mm x 3 pcs (Φ4-3/4" x 2-3/8" x 3 pcs) / Synthetic Rubber	Φ120 x 60 mm x 4 pcs (Φ4-3/4" x 2-3/8" x 4 pcs) / Synthetic Rubber
Roller Suspension	18 mm (3/4")	18 mm (3/4")	Roller Suspension	18 mm (3/4")	18 mm (3/4")
Net Weight	27 + 34 Kg (59 + 75 Lb)	32 + 34 Kg (70 + 75 Lb)	Net Weight	29 + 34 Kg (64 + 75 Lb)	34 + 34 Kg (75 + 75 Lb)
Gross Weight	29 + 36 Kg (64 + 79 Lb)	34 + 36 Kg (75 + 79 Lb)	Gross Weight	31 + 36 Kg (68 + 79 Lb)	36 + 36 Kg (79 + 79 Lb)
Carton for Body	560 x 540 x 290 mm (22" x 21-1/4" x 11-1/2")	770 x 560 x 290 mm (30-3/8" x 22" x 11-1/2")	Carton for Body	560 x 540 x 290 mm (22" x 21-1/4" x 11-1/2")	770 x 560 x 290 mm (30-3/8" x 22" x 11-1/2")
Carton for Stand	770 x 320 x 290 mm (30-3/8" x 12-5/8" x 11-1/2")	770 x 320 x 290 mm (30-3/8" x 12-5/8" x 11-1/2")	Carton for Stand	770 x 320 x 290 mm (30-3/8" x 12-5/8" x 11-1/2")	770 x 320 x 290 mm (30-3/8" x 12-5/8" x 11-1/2")
20' Container Loading	185 Sets (370 Cartons)	150 Sets (300 Cartons)	20' Container Loading	185 Sets (370 Cartons)	150 Sets (300 Cartons)

HEAVY DUTY

AF14



COPYING FEEDER

Ideal for Circumference Profiling or Edge Banding.

AF19 & AF19N



RESAW FEEDER

Ideal for Resaw over 600 mm(24")
AF19N (AF19 with Pneumatic)

DS300



EASY FEEDER

With Smart Stand
Memo-Lock System

DS400



EASY FEEDER

With Smart Stand
Memo-Lock System

Model	AF14	Model	AF19	Model	DS300	Model	DS400
Horsepower / Rotation	1/2 HP (0.375 KW), 1 or 3 phase ; Forward / Reverse	Horsepower / Rotation	1/2 HP (0.375 KW), 1 or 3 phase ; Forward	Horsepower / Rotation	0.5HP(0.4KW), 1 or 3PH; Forward/Reverse	Horsepower / Rotation	0.5HP(0.4KW), 1 or 3PH; Forward/Reverse
Range of Speeds (50Hz)	2/3/4/6/7/10/15/20 M/min (7/9.5/14/19/24/32/48.5/63.5 FPM)	Range of Speeds (50Hz)	1/2/2.3/3.5/4/6/7/7.5/12/15 M/min (3.5/7/7/11/14/20/22/25/40/50 FPM)	Range of Speeds (50Hz)/(60Hz)	2-22 M/min (7-72 FPM)	Range of Speeds (50Hz)/(60Hz)	2-22 M/min (7-72 FPM)
Range of Speeds (60Hz)	2/2.5/4/5/7/9/14/18.5 M/min (7/9/14/18/23/30/46/60 FPM)	Range of Speeds (60Hz)	1.5/2.5/2.5/4/5/7.5/8/9/15/18 M/min (4/8.5/8.5/14/17/25/28/30/50/60 FPM)	Rollers (Belts)	Φ120 X 25 mm X 6 pcs (Φ4.8" X 1" X 6 pcs) / PC	Rollers (Belts)	Φ120 X 25 mm X 6 pcs (Φ4.8" X 1" X 8 pcs) / PC
Optional Speeds (w/extra gear set)	•	Rollers	Φ175 x 40 mm x 2 pcs (Φ6-7/8" x 1-9/16" x 2 pcs) / Cast Steel (optional with PU roller)	Roller Suspension	18 mm (3/4")	Roller Suspension	18 mm (3/4")
Rollers (Belts)	Φ180 x 40 mm x 1 pcs (Φ7" x 1-9/16" x 1 pcs) / PU	Max. Roller-Blade Clearance	210 mm (8-1/4")	Net Weight	19 + 41 + 10 Kg (42 + 91 + 22 Lb)	Net Weight	23 + 41 + 10 Kg (51 + 91 + 22 Lb)
Roller Suspension	25 mm (1")	Net Weight	79 Kg (176 Lb)	Gross Weight	21 + 43 + 11 Kg (47 + 95 + 24 Lb)	Gross Weight	25 + 43 + 11 Kg (55 + 95 + 24 Lb)
Net Weight	20 + 34 Kg (44 + 75 Lb)	Gross Weight	97 Kg (209 Lb)	Carton for Body	588 x 326 x 306 mm (23" x 12-3/4" x 12")	Carton for Body	686 x 326 x 316 mm (27" x 12-3/4" x 12-3/8")
Gross Weight	22 + 36 Kg (49 + 75 Lb)	Packing Size	1220 x 480 x 470 mm (48" x 18-7/8" x 18-1/2")	Carton for Stand	770 x 320 x 290 mm (30-3/8" x 12-5/8" x 11-1/2")	Carton for Stand	770 x 320 x 290 mm (30-3/8" x 12-5/8" x 11-1/2")
Carton for Body	560 x 540 x 290 mm (22" x 21-1/4" x 11-1/2")	20' Container Loading	125 Sets (125 Wooden Cases)	Carton for Overarm	1080 x 60 x 60 mm (42-1/8" x 2-3/8" x 2-3/8")	Carton for Overarm	1080 x 60 x 60 mm (42-1/8" x 2-3/8" x 2-3/8")
Carton for Stand	770 x 320 x 290 mm (30-3/8" x 12-5/8" x 11-1/2")			20' Container Loading	224 Sets (672 Cartons)	20' Container Loading	205 Sets (615 Cartons)
20' Container Loading	185 Sets (370 Cartons)						

ACCESSORIES

UNIVERSAL STAND >

US01 (Light-Duty)



US02 (Medium Duty)

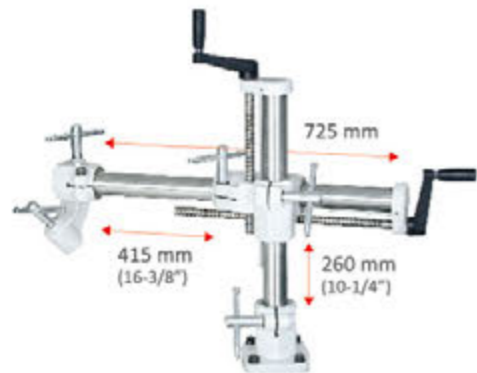

US13 (Heavy-Duty)



SMART STAND >

SS03 (Heavy-Duty)



QUICK HOLDER >

QH01

Boring-Free & Quick-Mount.
Applicable for All Light-Duty Models : M3, AF32

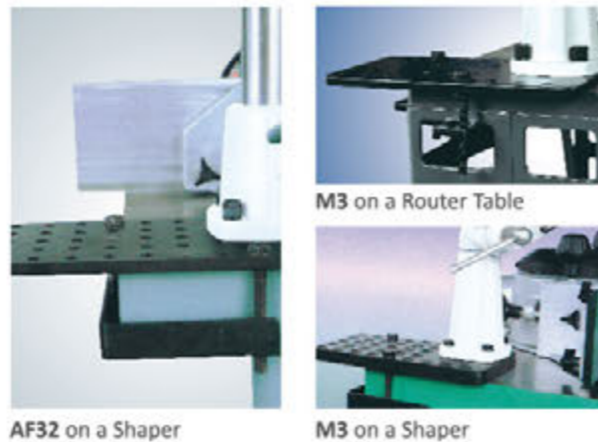

AF32 on a Shaper

M3 on a Shaper

ROLLER & BELT >

Cost Saving FRIENDLY ROLLER Set(RO120A, RU120A) with REPLACEABLE ROLLER TIRE (RO120, RU120)

 RO120 RUBBER TIRE Φ120 x 60 mm W. (Φ4-3/4" x 2-1/4") 12 PCs/Case	 RO120F ROLLER WHEEL Φ120 x 60 mm W. (Φ4-3/4" x 2-1/4") 12 PCs/Case	 RO120A FRIENDLY ROLLER, RUBBER  RU120A FRIENDLY ROLLER, PU Φ120 x 60 mm W. (Φ4-3/4" x 2-1/4") 12 PCs/Case AF34, AF44, AF38, AF48	 RO12 ROLLER Φ120 x 60 mm W. (Φ4-3/4" x 2-1/4") 12 PCs/Case AF34, AF44, AF38, AF48	 RS12 SERRATED ROLLER Φ120 x 60 mm W. (Φ4-3/4" x 2-1/4") 12 PCs/Case AF34, AF44, AF38, AF48
 GR12 ROLLER Φ120 x 60 mm W. (Φ4-3/4" x 2-1/4") 12 PCs/Case DC30, DC40, DS300, DS400, EZ300, EZ400	 RU21 SEPRATED ROLLER Φ120 x 25 mm W. (Φ4-3/4" x 1") 2 PCs/Set DC30, DC40, DS300, DS400, EZ300, EZ400	 RO05 ROLLER Φ48 x 60 mm W. (Φ1-7/8" x 2-3/8") 14 PCs/Case	 RO10 ROLLER Φ100 x 50 mm W. (Φ4" x 2") 12 PCs/Case AF308	 RO08 ROLLER Φ80 x 30 mm W. (Φ3-1/8" x 1-3/16") 12 PCs/Case AF32
 RO07 ROLLER Φ76 x 30 mm W. (Φ3" x 1-3/16") 12 PCs/Case M3	 RU18 PU ROLLER Φ180 x 40 mm W. (Φ7" x 1-9/16") 1 PC AF14, AF14T	 RU18A PU ROLLER SET (with Adaptor) Φ180 x 40 mm W. (Φ7" x 1-9/16") 2 PCs/Set AF19(N), AF19T	 RS18 SERRATED ROLLER Φ175 x 40 mm W. (Φ6-7/8" x 1-9/16") 2 PCs/Set AF19(N), AF19T	 33B BELT 1118 L x 12.7 mm W. (44" L x 1/2" W.) 3 PCs/Set AF04



INTEGRITY

Tell the Truth.
Devotion to the Commitments.



INNOVATION

Technology Breakthrough.
Management Development and Marketing Planning.



GLOBALIZATION

International Business Relationship.
No Geographical Limits.



CUSTOMER PARTNERSHIP

Develop Long Term Strategic Relationship.
Deliver Quick Service and Solutions.

LEADING MANUFACTURER FOR POWER FEEDER WORLDWIDE

Established in 1984, CO-MATIC is the world's largest dedicated power feeder provider in woodworking industry. CO-MATIC has built its reputation on offering wide range of stock and specialty power feeder with promising quality and satisfactory customer service.

Products are now sold to more than 70 countries worldwide.

CO-MATIC headquarter and manufacturing facility is located in Taichung City Taiwan, with a subsidiary company and factory (PRO-MATIC) in Guangzhou China.

PRO-MATIC China is a subsidiary company 100% owned by CO-MATIC. It is located in Guangzhou, as a pioneer of feeder business in China for domestic and overseas markets.

PRO-MATIC was registered in 1998, and the first factory was set up in 2001 to fulfill the increased demand.

Over the years, PRO-MATIC had gained more than 50% of the domestic market share. A new state-of-art and 15,000sqm factory was then built in 2007 with total investment of five million US dollars.

PRO-MATIC has now become the leader of power feeder provider in China.

- 1984** Company Founded by Mr.Oscar Lin
- 1986** Sales covered over 30 countries including England, France, Germany, Italy, Japan, U.S., ... etc.
- 1987** (1) World's largest O.D.M Power feeder MFG.
(2) Computerized Management.
- 1988** "Superior Product Award" by TWMA/CETRA.
- 1991** "Superior Quality Award" by TWMA/CETRA.
- 1992** Sales covered more than 50 countries with 50% market share in Germany and U.S.A.
- 1993** Implemented 1st die casting feeder housing for high quality. Set new standard in the industry.
- 1994** Taiwan 1st C.E approved woodworking machine MFG.
- 1995** World's 1st C.S.A and U.L approved power feeder.
- 1996** (1) TÜV certified ISO-9002.
(2) Introduction of world's smallest power feeder.
- 1997** (1) Products highlighted by the article in "American Woodworking".
(2) "Magazine Good Product Award" by TWMA/CETRA.
- 1999** (1) Introduction of flagship model : E.Z Feeder.
(2) Product highlighted by the article in "Fine Woodworking Magazine".

- 2001** Introduction of Track Feeder.
Establish subsidiary company (PRO-MATIC) in Guangzhou China.
- 2002** (1) Introduction of Saw-Mate.
(2) TÜV certified ISO-9001.
- 2004** (1) Developed Pneumatic Bandsaw Feeder.
- 2005** Completion of New Office
- 2007** (1) New factory completion in PRO-MATIC in Guangzhou China.
(2) Introduction of Joint-Mate.
- 2009** Introduction of Auto Jointer-specialized in 16" jointer with efficiency improvement by 300%-500%.
- 2010** Revolutionary feeder is brought into market for 600/700mm bandsaw, router, and sander ... etc.
- 2011** Introduction of the most popular 4 rollers 8 speeds power feeder model-easy operation, high durability and fascinating outlook.
- 2012** Introduced brand new product category, The Le-Matic AR Series Portable edgebanding system.
- 2014** Launched 4th generation of the Le-Matic BR Series Digital control portable edge banding system.
- 2015** Celebrating 30th establishment by introducing two cutting edge innovation products: The Co-Matic DC Servo Motor Power Feeders and the Digital Wireless 5th generation Portable Edgebander.

