

Production



Sales



Service

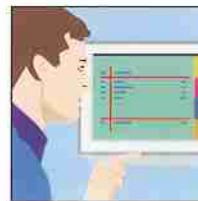
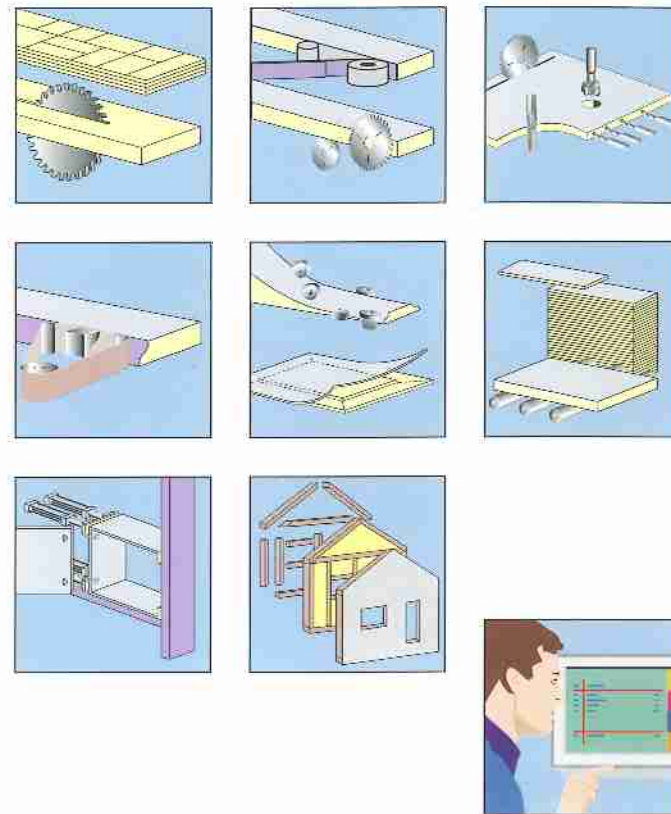

Werb Office

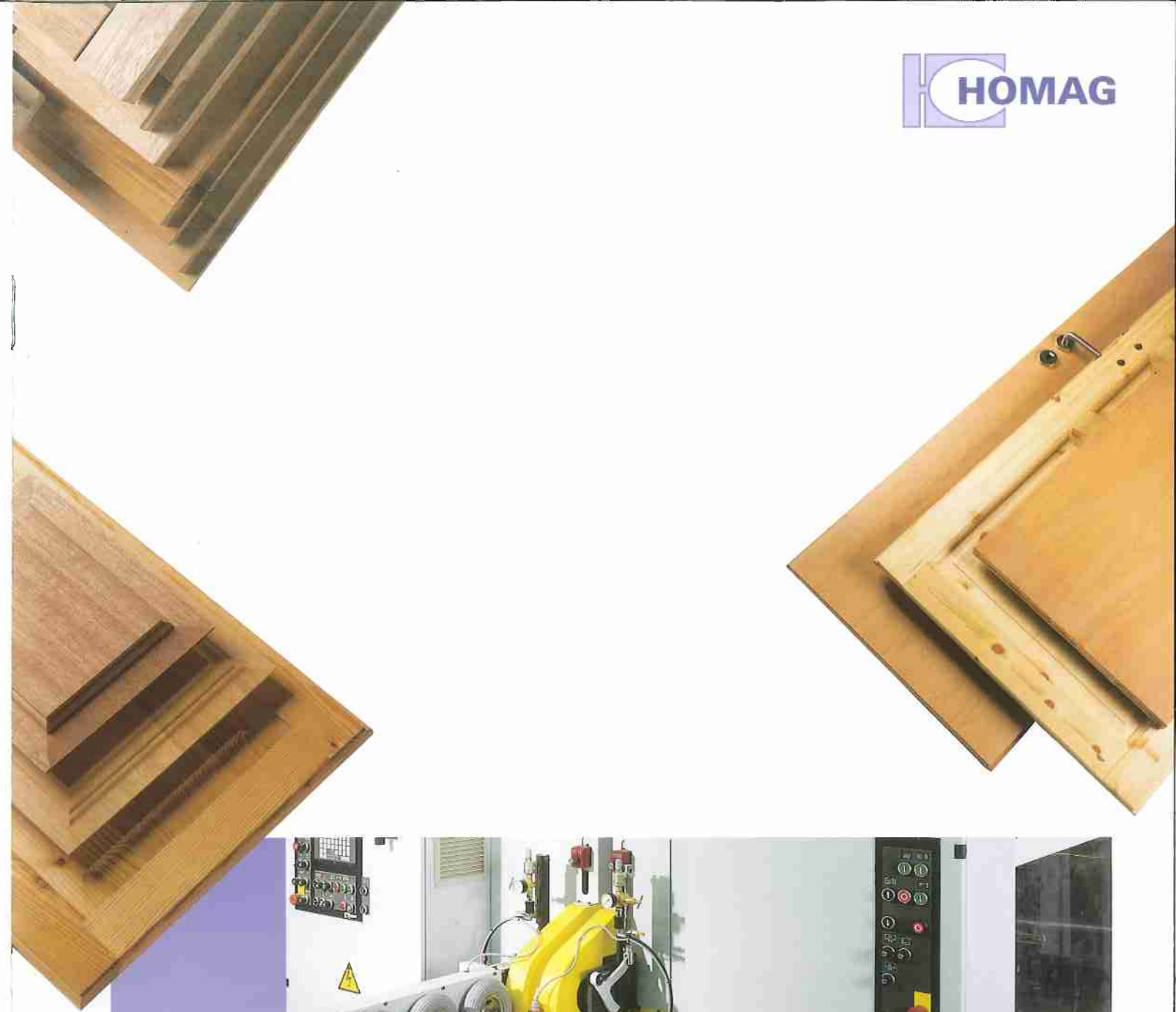

Double-end tenoner NFL 25 – NFL 26

Productive and
efficient sizing and
edge banding

Your contact:



HOMAG Holzbearbeitungssysteme AG
Homagstrasse 3-5
D-72296 Schopfloch
Tel. +49 (74 43) 13-0
Fax +49 (74 43) 13 23 00
info@homag.de
<http://www.homag.com>

NFL 25 / NFL 26 E/4.00

Double-sided processing – double the output

Double-end tenoners from Homag are reliable, compact "workhorses" designed to perform a whole range of functions: Angular and inclined cuts, sizing, profiling, rebating, grooving and corner processing... Perhaps you are aiming to enter the lucrative parquet market, or to produce windows, doors, fronts and panels?

With their hard-wearing, low-wear, low-maintenance technological concept, these machines are characterized by high output and maximum availability: Just the job for tough, everyday operation.

Success in bulk quantities

Two passes – one longitudinal, one transverse – are sufficient to process all four sides of your workpieces. Switching both passes in succession opens up scope for enormous production increases – through to the compact production line with continuous material flow, including loading and stacking. The control system and processing unit technology permit simple resetting – meaning bulk output even when producing small runs or frequently changing batch types.



Operating convenience as standard

Homag double-end tenoners with their Homatic NC 16 control system are outstandingly simple to operate and program. Using the display and operator prompt system, you can communicate in "plain text" with your machine right from the start: You are guided through the entire process in simple steps. Input errors are practically eliminated: Frequently required settings can be conveniently stored in the form of processing programs. The NC 16 is equipped ex works with three basic programs, covering the majority of all the work processes you will need. And error messages appear directly on screen, permitting fast response by the machine operator thus minimizing standstill periods.

Throughfeed: Maximum speed, reliability and workpiece care



Height and width adjustment
The linear guide at the fixed machine bearing and recirculating ball spindle ensures easy-running, fast adjustment precisely to digitally entered width dimensions. Height adjustment of the top pressure beam is powered by a maintenance free cardan drive system (optional feature). Low-play adjustable mechanisms guarantee a high degree of dimensional and repeat accuracy.



“Transverse” workpiece transport using stop dogs
An ingenious system of retractable stop dogs ensures precise angular positioning of workpieces during transverse processing. The dogs are adjustable – infinitely variable adjustment an optional feature – and are simply retracted into the chain links during longitudinal processing. They ensure reliable transport of even profiled or softforming components through the machine without damage.

Heavy-duty chain links for easy transport
Together with the torsion-resistant top pressure beam, the chain tracks guarantee reliable, precise workpiece guidance. The individual elements of the block link chain run on precision guides mounted in ball bearings at the running and guidance surfaces, ensuring easy running and reliably preventing lateral displacement.

The workpiece feed is infinitely variable and can be precisely adjusted in line with tool and material requirements. The rubber and plastic chain backing is designed to ensure maximum care of delicate workpiece surfaces.

Longitudinal and transverse precision
NFL 25: First machine for longitudinal feed
NFL 26: Second machine with extended chain track for transverse feed



The range of modular processing units – always at the cutting edge of technological development

A wide range of units is available to address the most varied processing requirements, and is continuously being extended and updated. Why not simply enquire – we will be pleased to advise you.

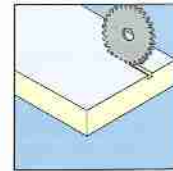

Prescoring saw above
For splinter-free processing of coated surfaces or for clean-cut transverse processing of veneered parts or solid wood.
Scoring motor 2.2 kW
Tool diameter max. 180 mm

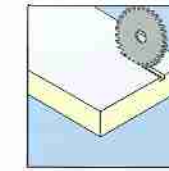
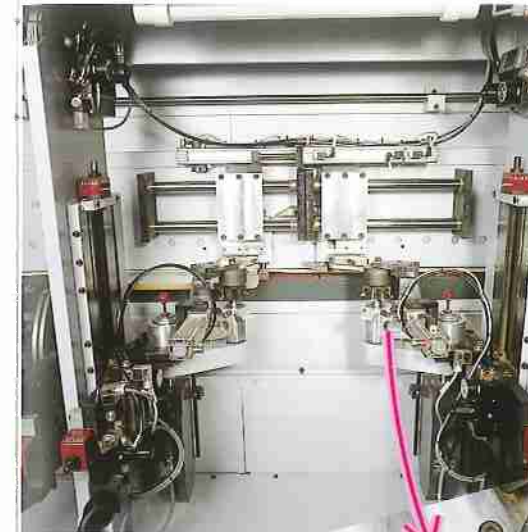

Corner rounding unit
For radii of up to 30 mm at the leading and trailing edge of the workpiece.

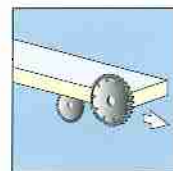
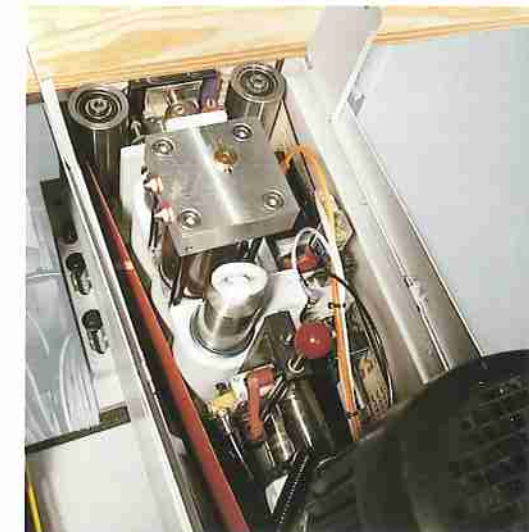

Scoring / hogging
Perfect sizing without tear-out, also for coated substrates. Pre-scoring unit with lift-out device. Hogging unit with cross support and extractor hood.

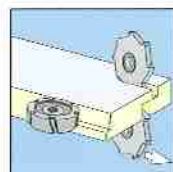
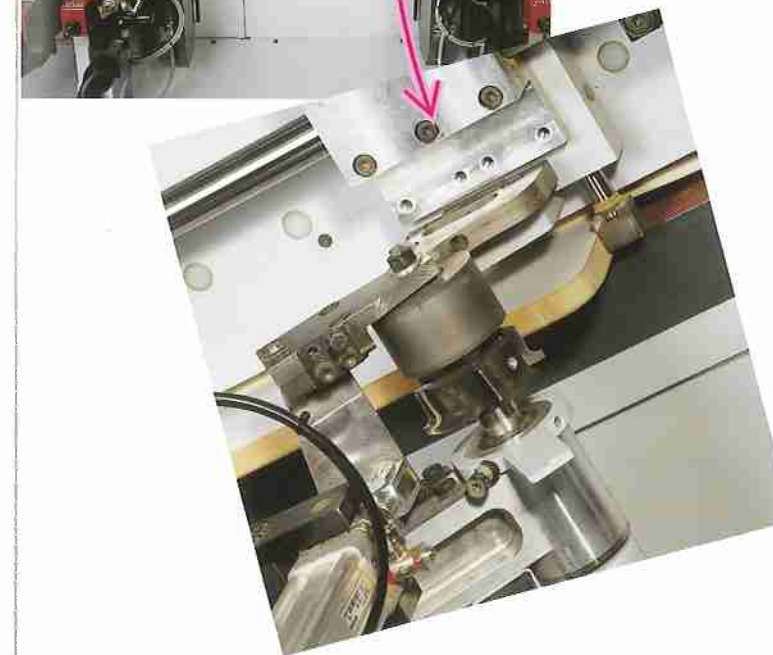

Standard trimming unit
For finish trimming, rebating, profiling, grooving etc. Electropneumatically controllable, swivel range 90°. Cross support and reversing switch to govern the sense of tool rotation.

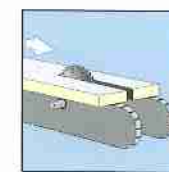
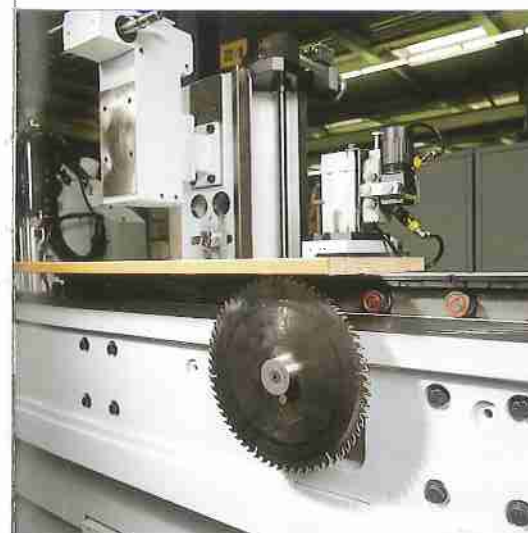

Central cutting flange
For separation in the range from 140 to 310 mm, providing twice the output when processing double widths.



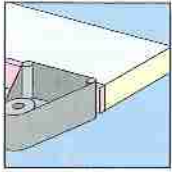

Belt sanding unit KS 10

For sanding straight edges. Vertical oscillation ensures even sanding and optimum utilization of the belt. Long belt (2100 mm), two belt speeds.

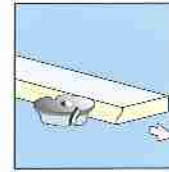
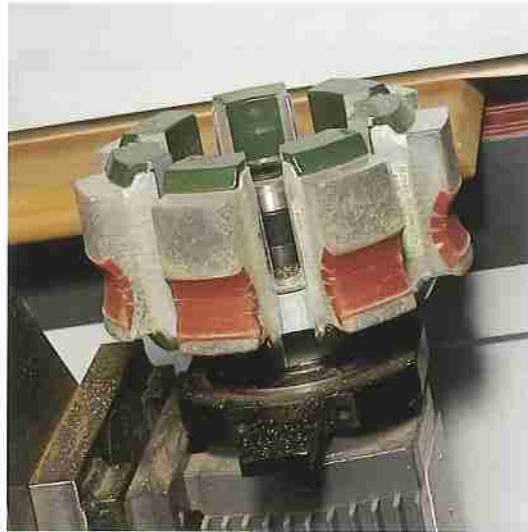

Disc sanding unit NFL

With profile disc for profiled edges. For sanding constant radii on solid wooden panels or MDF.

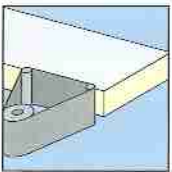

Profile sanding unit PS 10

For sanding profiles and straight edges. Long belt (2500 mm), two belt speeds, cleaning of the belt by means of air jet, swivel range up to 45°. Easy-exchange sanding pad.

Option: Belt oscillation

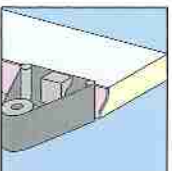
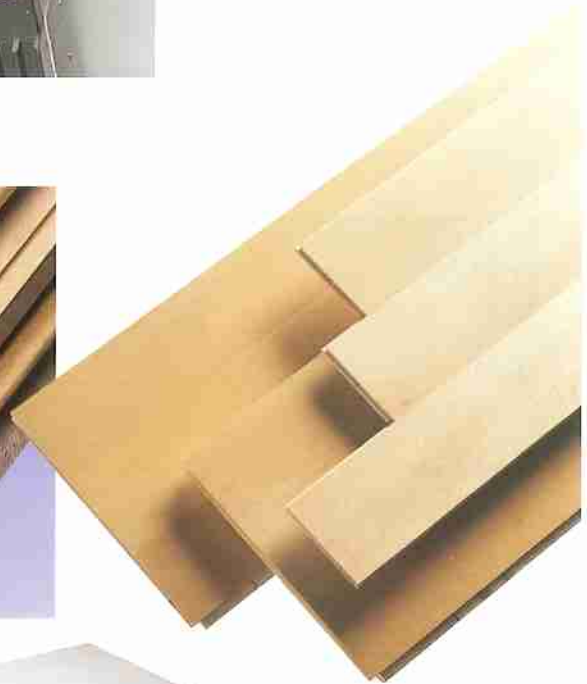

Belt sanding unit PS 20

With a belt length of 3200 mm and the facility to sand special profiles with two separate sanding pads which can be independently adjusted (double-pad technique).

Technical specifications

NFL 25/4

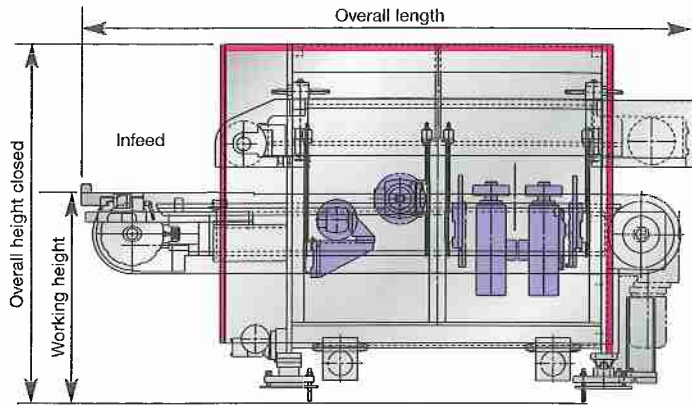

NFL 26/4

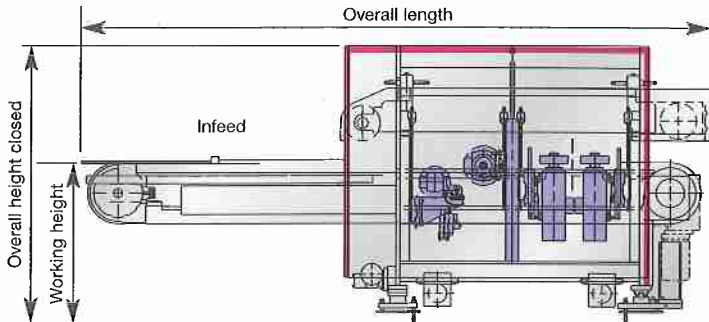

NFL 26/4

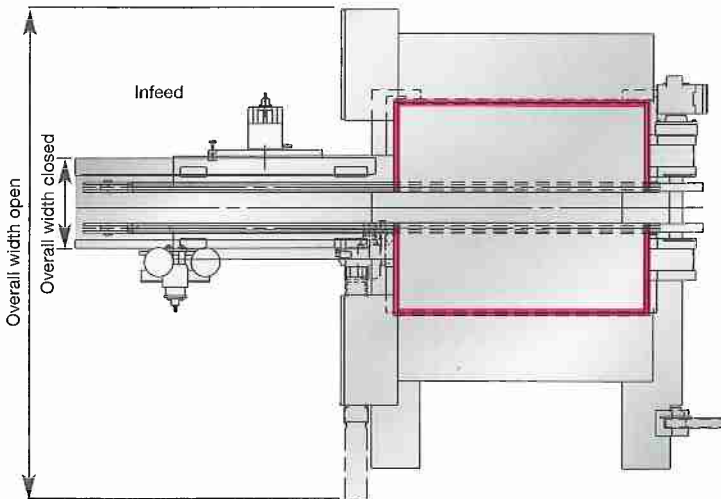

Machine dimensions

Overall length, single machine	mm
NFL 25/4	3150
NFL 25/6	4150
NFL 25/8	5150
NFL 26/4 Without workpiece transfer device	4115
NFL 26/6 Without workpiece transfer device	5115
NFL 26/8 Without workpiece transfer device	6115
NFL 26/4 With workpiece transfer device	4385
NFL 26/6 With workpiece transfer device	5385
NFL 26/8 With workpiece transfer device	6385

Overall width

With noise cover = Working width +	
Closed / open	mm 2160 / 3300
With PS 10	2300 / 3300

Overall height

With noise cover	
Closed / open	mm 1685 / 2150
With PS 10	1685 / 2150
Working height	950

Working dimensions

Workpiece width	min. double-sided	150
	max. double-sided	1000 / 1500 / 2000 / 2500 / 3000

Workpiece thickness	min. mm	8
	max. mm	120

Workpiece overhang	min. mm	10
	max. mm	110

Normal voltage	400 V/50 Hz
Control voltage	24 V

Compressed air connection	bar	6-8
		G 1/2" female thread

Miscellaneous

Feed	m/min	8-25
------	-------	------

Width adjustment speed

Standard machine	m/min	2,5
------------------	-------	-----

Dog spacing	mm	1000
-------------	----	------

Standard dog height	mm	18
---------------------	----	----

Option: infinitely variable	max. mm	25
-----------------------------	---------	----