

CNC8000

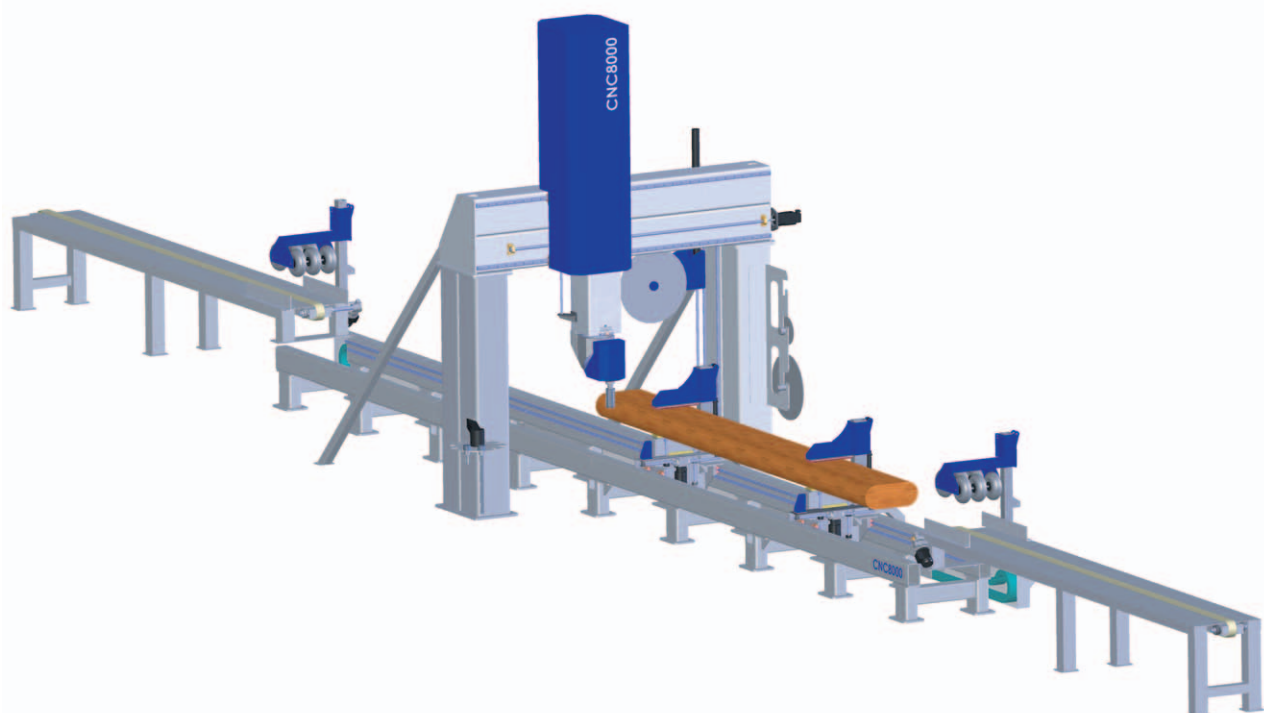

**MORETENS**

# CNC8000

- Flexible 6-axes machining of construction timber
- Integrated automatic materials handling
- Integrated automatic tool changing
- Automatic machining can take place from all directions by tilting the parts
- By resetting the clamping carriages all surfaces can be machined
- The re-clamping allows longer parts to be machined
- Cutting can be carried out at all angles

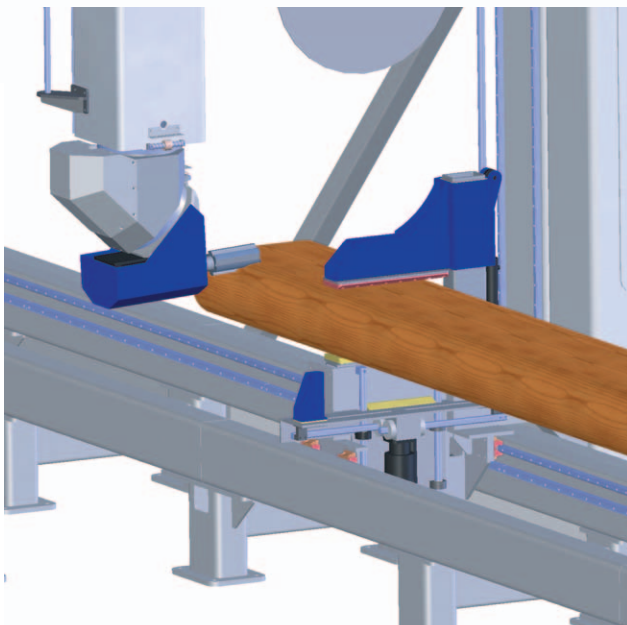
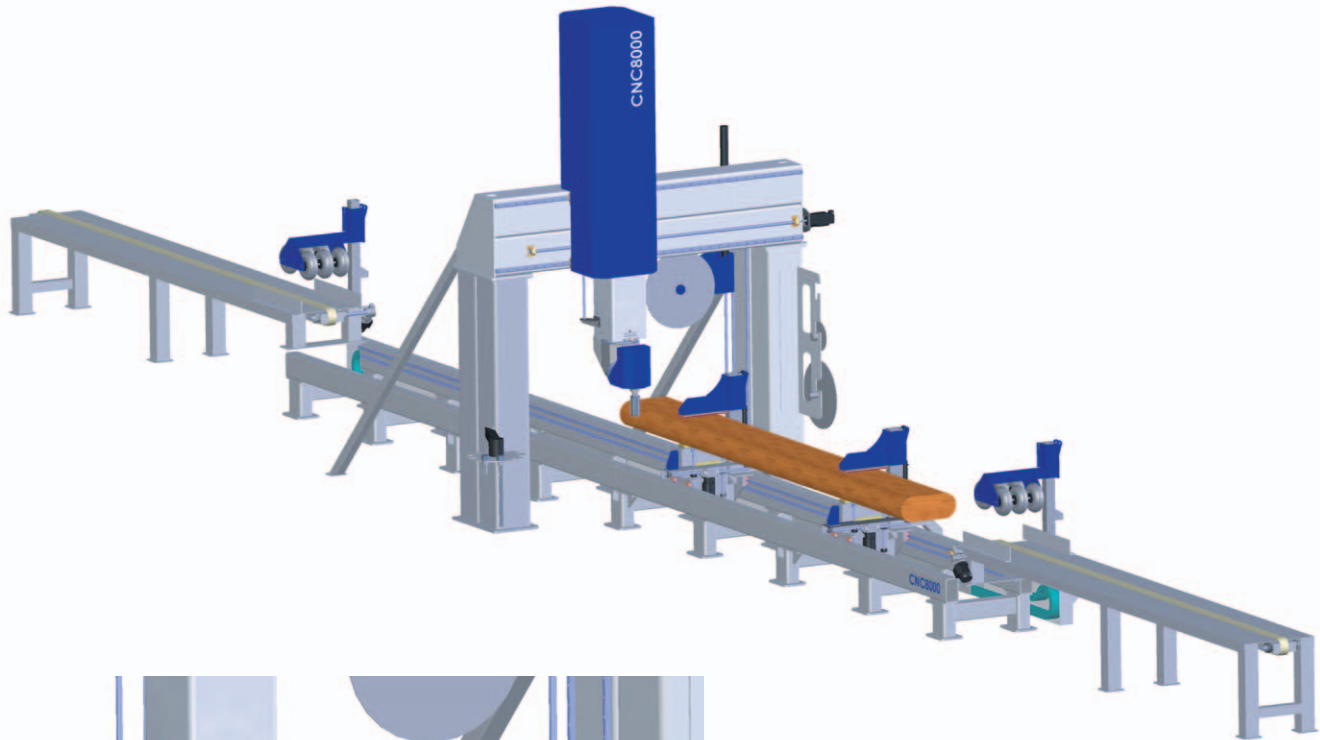
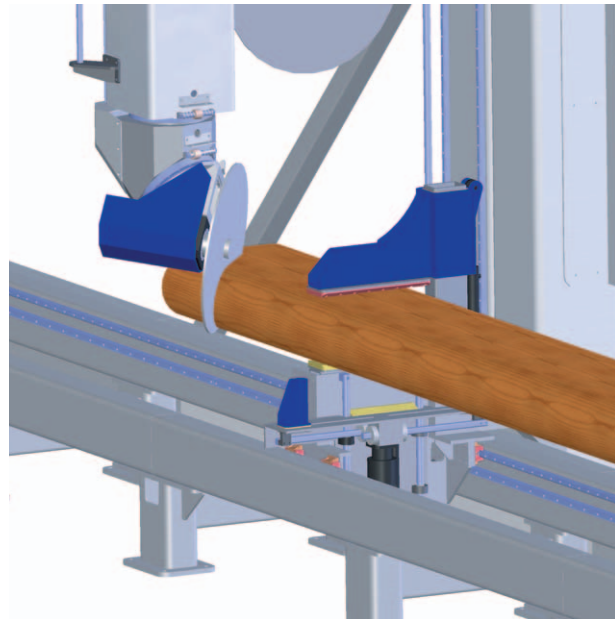

- Enables machining of conical parts, e.g. timber house logs
- Industrial control system
- Digital servos for greater efficiency and reduced vibrations
- Interface for PC and CAM software
- Portal design for improved stability
- Enables custom designs

CNC8000 has been specially developed for construction timber.

The machine is ideal for:

- companies conducting machining of glulam beams
- timber house manufacturers that set stringent requirements
- companies that machine supporting structures for construction work, e.g. roof truss manufacturers
- companies that machine poles

### Flexible 6-axes machining

The machine is built up around 6 axes (degrees of freedom), which can be freely programmed.

Axis X1 and X2 control the two clamping carriages.

The Y axis controls the lateral movement on the portal.

The Z axis controls the vertical movement on the portal.

The 4th axis controls the turning for tilting of the spindle motor.

The 5th axis controls the tilting of the spindle motor.

### Spindle motor

The spindle motor has built-in automation for tool changing. It has an output of 20 kW, with increased torque at low speed. It has the capacity to handle a circular saw blade up to 700 mm in diameter, which enables a cutting depth of up to 300 mm. The motor also ensures high efficiency during cutting.

### Clamping carriages

The clamping carriages enable a variety of functions:

- Integrated automatic materials handling  
The clamping carriages dock at the infeed conveyor. The conveyor feeds in the part. The clamping carriages follow the part, adjust the side position and clamp the part.
- Tilt function  
When the clamping carriages have securely clamped the part it can be tilted up to 90 degrees. The tilting is monitored and controlled to ensure rapid and smooth movement. Automatic machining can take place from all angles by tilting the part.
- The clamping carriages can be freely programmed, either separately or in pairs at a fixed distance.
- Longer parts can be machined when the clamping carriages are reset.

### Machining chamber

A machining chamber is supplied as standard, which encloses the machining zone. It functions both as protection and as a collecting magazine for shavings.

### Control system

The machine's control system has an industrial design and uses advanced technology. The control system can be connected to a network or USB port to a PC.

The control system accepts programs as per the ISO6983 standard, and therefore a large number of different CAM programs can be used both for 2D and 3D.

The machine has digital servos for greater efficiency and reduced vibrations.

Also available in a smaller model, designated CNC7000.

### Accessories, options

- Cutting station with fixed angle
- Third clamping carriage
- CAM software
- Machine guard round the machine
- Shavings extraction system
- Light curtain
- Adjusted rotating tool

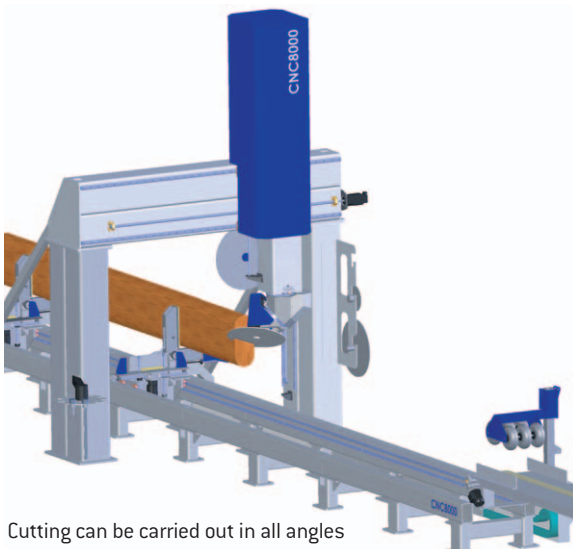
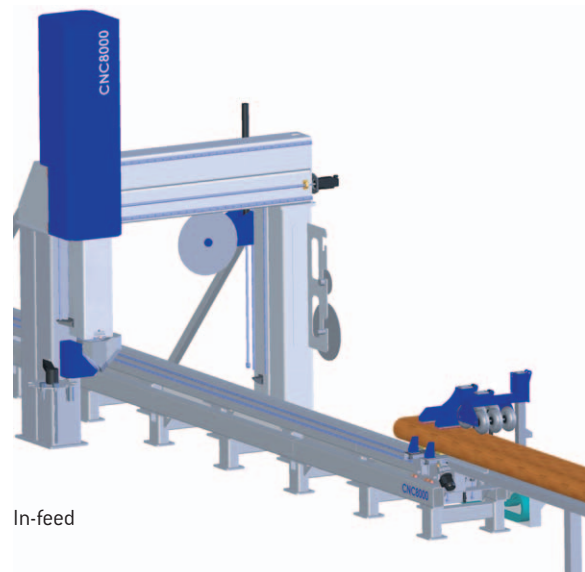

Cutting can be carried out in all angles

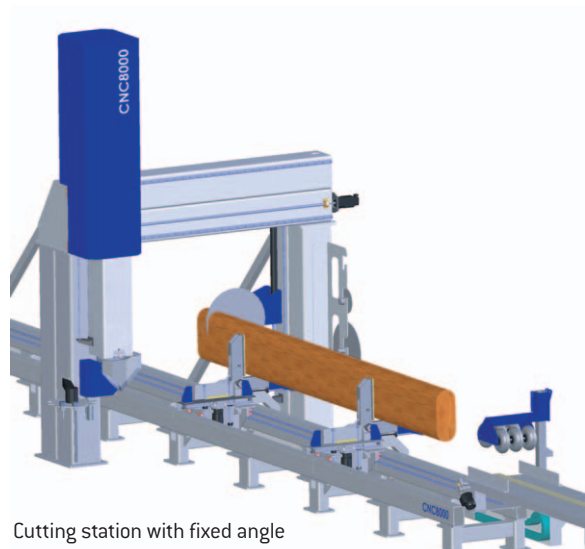

Cutting station with fixed angle

## Technical data

	CNC 8000	Option	CNC 7000
<b>Range</b>			
X axis, lengthwise	13,100 mm		12,900 mm
Y axis, sideways	2,600 mm		1,500 mm
Z axis, vertically	1,100 mm		600 mm
4th axis	360 degrees		360 degrees
5th axis	90 degrees		90 degrees
<b>Part size</b>			
X axis, length	6,000 mm	15,000 mm	6,000 mm
Y axis, width	600 mm		200 mm
Z axis, thickness	260 mm	310 mm	200 mm
<b>Speed</b>			
X axis	120 m/min		120 m/min
Y axis	40 m/min		40 m/min
Z axis	20 m/min		20 m/min
4th axis	3 sec/360 degrees		3 sec/360 degrees
5th axis	1.5 sec/90 degrees		1.5 sec/90 degrees
<b>Spindle motor w tool changing</b>			
Output	20 kW		8 kW
Taper	HSK63		HSK63
Max speed	18,000 rpm		18,000 rpm
Tool changing, fixed places,	3 tools		1 tools
Tool changing, rotation,	10 tools		10 tools
Total length excluding conveyors	15,200 mm		15,000 mm
Total width	4,500 mm		2,400 mm
Total height	5,250 mm		3,200 mm
Weight	approx 20,000 kg		approx 6,000 kg



Construction of a CNC 8000

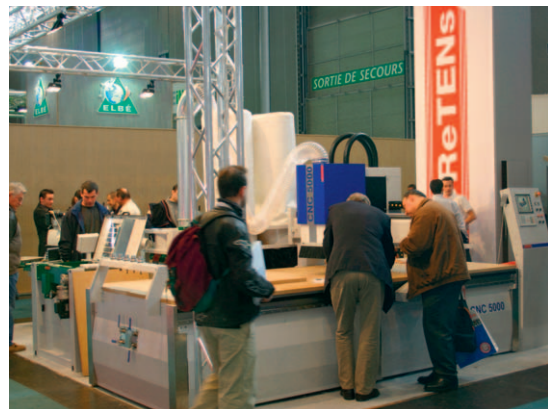

CNC 5000 at a major exposition in Paris

## Innovative woodworking machinery

MOReTENS have been manufacturing woodworking machinery in Sweden for over 25 years.



MOReTENS' Swedish manufacturing plant.  
All the Moretens range is produced to the highest quality standards.

[www.moretens.com](http://www.moretens.com)

Made in Sweden

**MOReTENS**