

accord range

numeric control machining centres

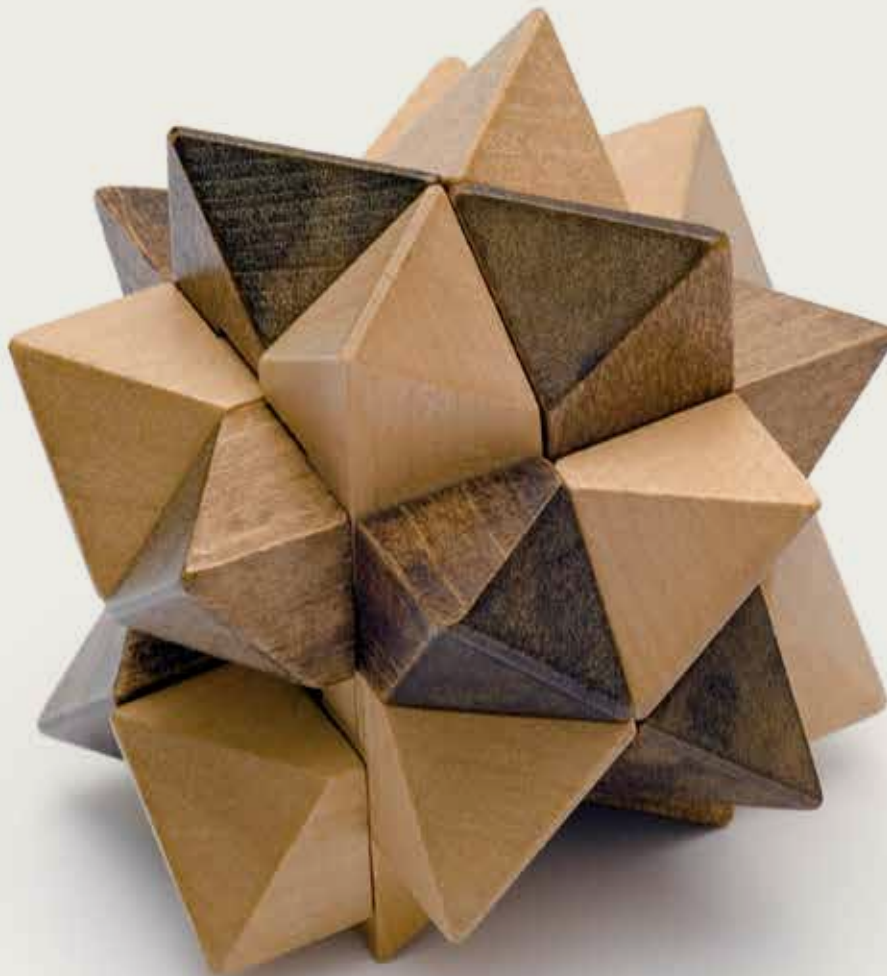

SOLID SKILLS FOR PERFECT PROCESSING





accord 25 fx
accord 40 fx
accord 42 fx
accord 50 fx



accord 25 fxm
accord 40 fxm
accord 42 fxm
accord 50 fxm



accord wd

THE LONGEST EXPERIENCE
IN SOLID WOOD MACHINING

6

ACCORD 25 FX/FXM

8

ACCORD 40 FX/FXM

10

ACCORD 42 FX/FXM

12

ACCORD 50 FX/FXM

14

ACCORD WD

PRECISION



Perfect finish quality

The architecture with fixed table and mobile gantry structure, consisting of a sturdy construction equipped with front and rear sliding guides, ensures maximum accuracy and finish quality over the entire work area.

STRENGTH



Heavy duty profiling

The PRISMA machining heads with 5 interpolating axes are designed for the processing of solid wood. The ideal solution for windows, doors and stairs.

RAPIDITY



Very high productivity

New combined TWIN machining head with 3 and 5 independent axes. The alternate use of the two routing units reduces the cycle time: while one unit is working, the other performs the tool change in masked time.

FLEXIBILITY



Rapid and precise set-up

The MATIC bars worktable with direct transmission system and independent drive units, assures the complete set-up in seconds.

Simple and quick replacement of clamps and suction cups through the exclusive rapid locking device.

Reliable technology

The SCM aluminium multi-function worktable guarantees perfect lasting planarity.

The direct integrated vacuum system allows the optimum work-piece hold down and the T-grooves are ideal for fitting of any type of mechanical locking equipment.

INNOVATION



Totally automatic

State of the art processes to guarantee the best production standards, such as work-piece loading and unloading systems, which enable the machine to work independently, without the continuous supervision of the operator.

Best-in-class performance

The integrated IoT platform displays, analyses and monitors all data received from connected machines. Data becomes useful information to increase machine productivity, reducing maintenance operations and cutting energy costs.

SAFETY



Ergonomic

The PRO-SPEED safety system with photocells and bumper protections, combines the safe access to the worktable and the maximum speed during machining.

42

Software

52

Technical data

TECHNICAL FEATURES OVERVIEW

TECHNOLOGICAL ADVANTAGES



PRISMA machining head with 5 axes electrospindle.



Multi-function worktable
suitable for any need of referencing and locking.

Bars worktable
configurable with clamps and suction cups, ideal for the processing of solid wood.

fxm

accord 25 fx/fxm

numeric control machining centres



*Side tool store
up to 12 positions.*



*Chain tool store
with 32 positions
anchored to the
mobile gantry
structure, developed
for managing heavy
and large tools.*

*Maximum
operator safety
thanks to
the compact
bumper
protections.*



*Total lack of
vibrations even at
high speed with
the mobile gantry
structure moved
by a double motor.*

TECHNICAL FEATURES OVERVIEW

TECHNOLOGICAL ADVANTAGES



The MACH 5 device in only five seconds replaces the tool drastically reducing down-times.



Bars worktable configurable with clamps and suction cups, ideal for the processing of solid wood.

Multi-function worktable suitable for any need of referencing and locking.

fxm

accord 40 fx/fxm

numeric control machining centres



PRISMA machining head with 5 axes electrospindle.



Additional BRC working unit with independent vertical axis.

Maximum operator safety thanks to the compact bumper protections.



Total lack of vibrations even at high speed with the mobile gantry structure moved by a double motor.

TECHNICAL FEATURES OVERVIEW

TECHNOLOGICAL ADVANTAGES



TWIN machining head with two independent routing units.



Rear routing unit with 3/4 axes electrospindle.



Front routing unit with 5 axes electrospindle.



Multi-function worktable suitable for any need of referencing and locking.

Bars worktable configurable with clamps and suction cups, ideal for the processing of solid wood.

fxm

accord 42 fx/fxm

numeric control machining centres

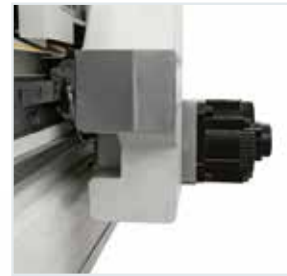

Total lack of vibrations even at high speed with the mobile gantry structure moved by a double motor.



Chain tool store with 48 positions anchored to the mobile gantry structure, developed for managing heavy and large tools.

Maximum operator safety thanks to the compact bumper protections.

TECHNICAL FEATURES OVERVIEW

TECHNOLOGICAL ADVANTAGES

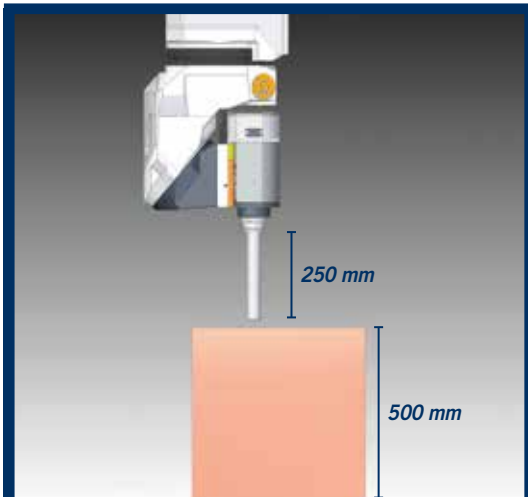

The increased stroke of the vertical axis allows machining of work-pieces up to 500 mm in height, using large dimensioned tools.



Circular tool store with 12 positions located on the machining head.



Bars worktable configurable with clamps and suction cups, ideal for the processing of solid wood.

Multi-function worktable suitable for any need of referencing and locking.

fxm

accord 50 fx/fxm

numeric control machining centres



PRISMA machining head with 5 axes electrospindle.

Maximum operator safety thanks to the compact bumper protections.



Total lack of vibrations even at high speed with the mobile gantry structure moved by a double motor.

TECHNICAL FEATURES OVERVIEW

TECHNOLOGICAL ADVANTAGES



Flexible work cell for the production of window and door frames, fitted with automatic loading and unloading.



Worktable with 145 mm height (H145)
to process elements of different thickness by using double-profile tools.



Chain tool store with 48 positions
anchored to the mobile gantry structure, developed for managing heavy and large tools.



PRISMA machining head with 5 axes electrospindle.

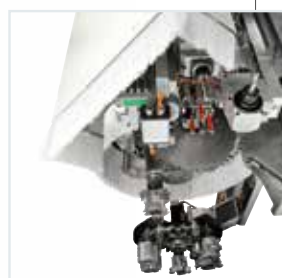

Additional BRC working unit with independent vertical axis.

Maximum operator safety thanks to the compact bumper protections.



Total lack of vibrations even at high speed with the mobile gantry structure moved by a double motor.

ARCHITECTURE

MOBILE GANTRY STRUCTURE

The machines of *accord* series are designed with a sturdy and highly ribbed mobile gantry structure that ensures maximum finish quality, accuracy and productivity.

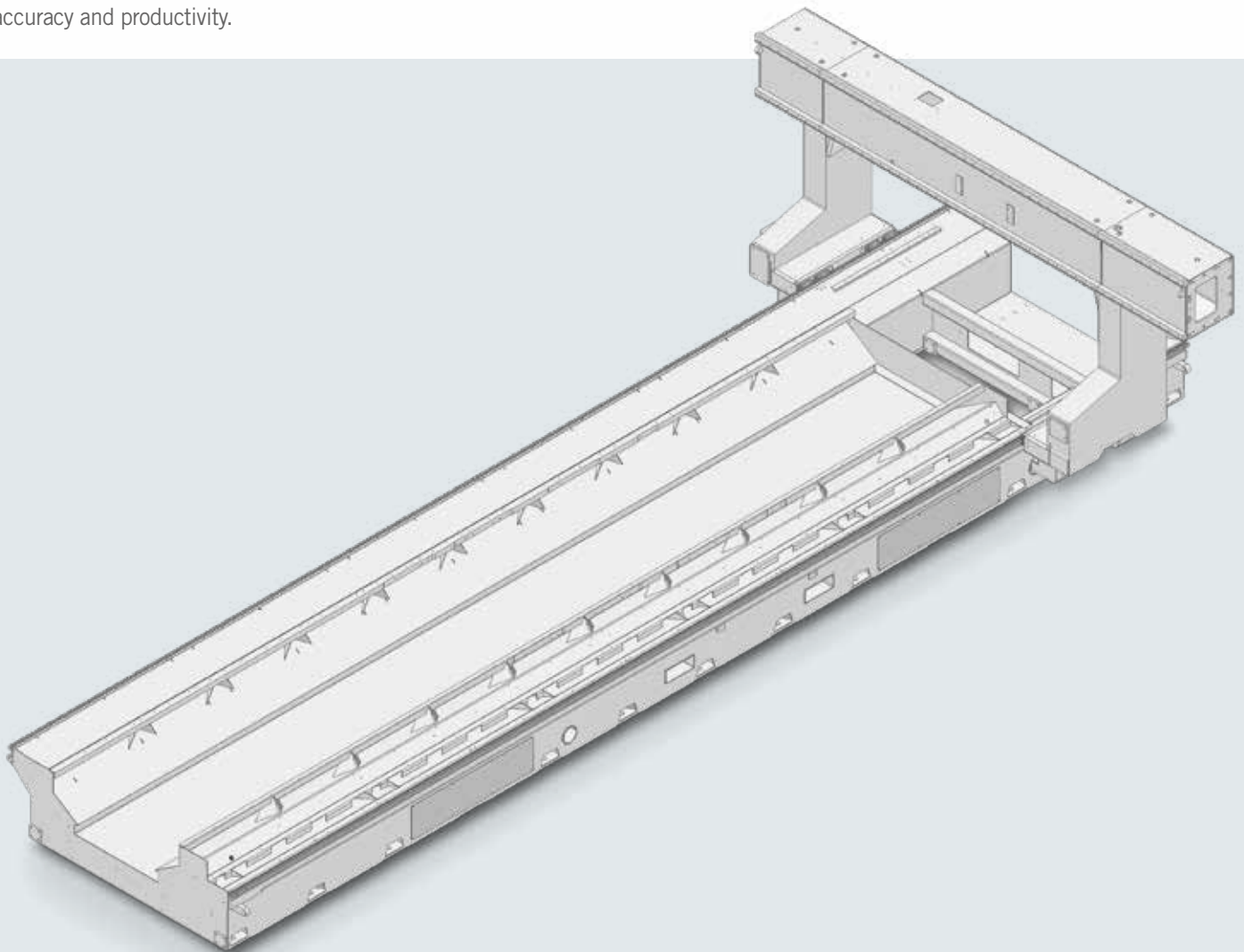

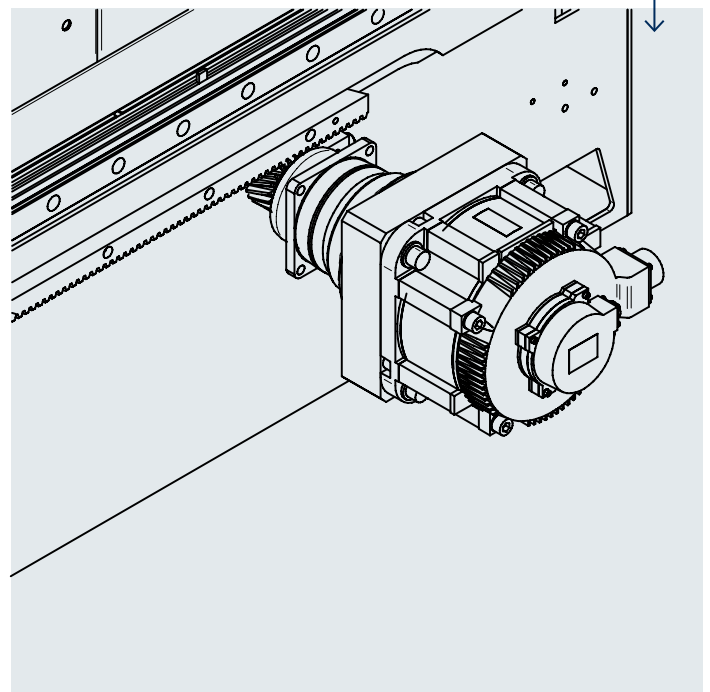
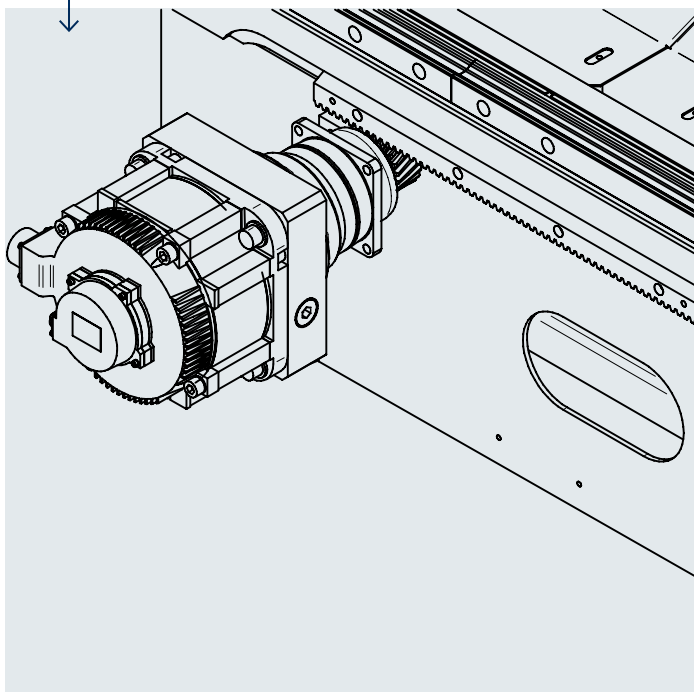
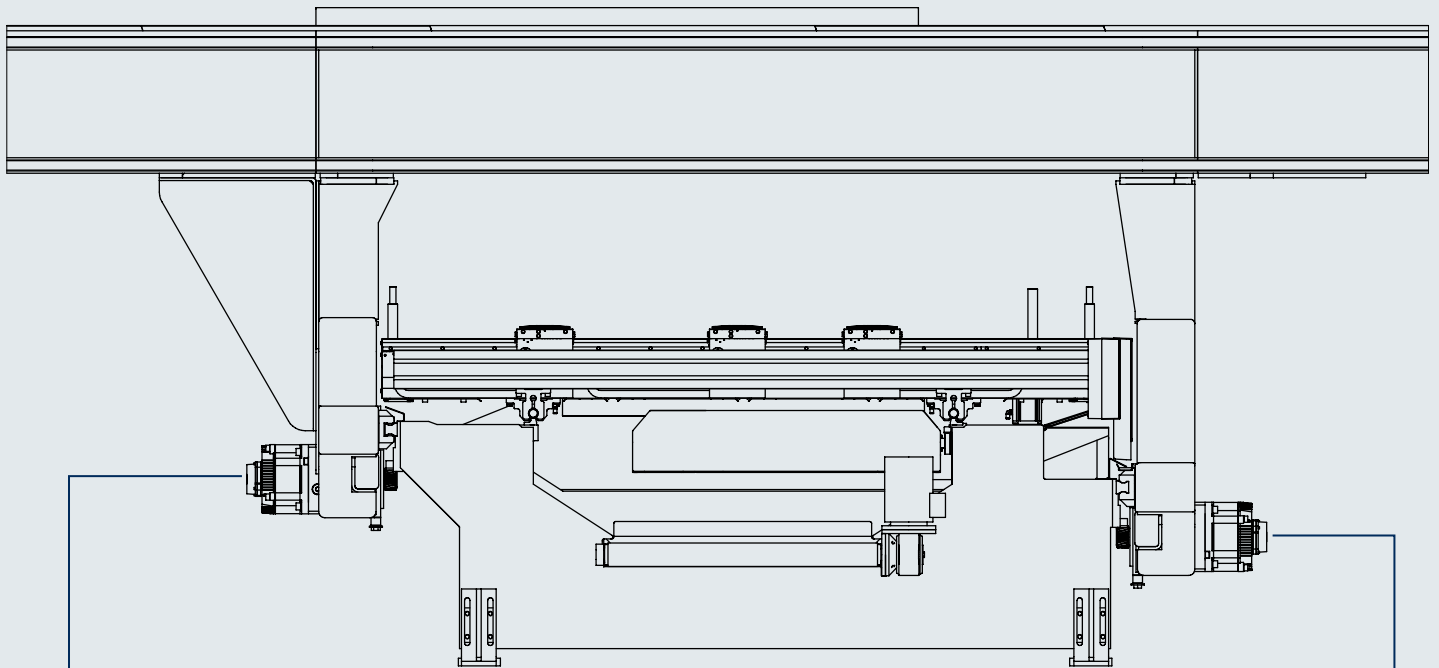

Double rack-and-pinion and **twin motors** to guarantee fast movements and maximum precision by means of the X-axis sliding with gantry system.

MACHINING UNIT

Heavy duty profiling, maximum flexibility and best finish quality thanks to the PRISMA machining heads with 5 interpolating axes.

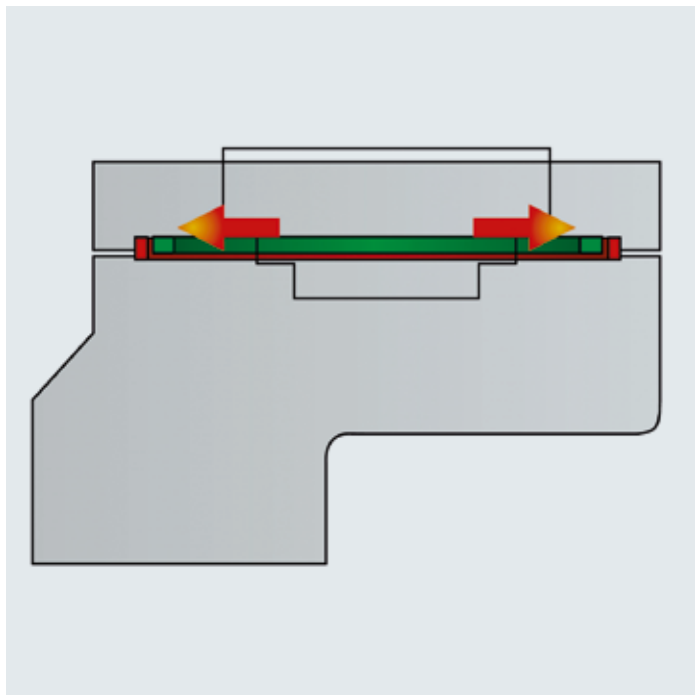

The TTS (Total Torque System), unique to SCM, **mechanically locks the rotating axis in vertical position**, increasing system stiffness.





MACHINING UNIT

The geometry of PRISMA machining heads allows them to operate at **angles of up to 10°** below the work-piece supporting surface.

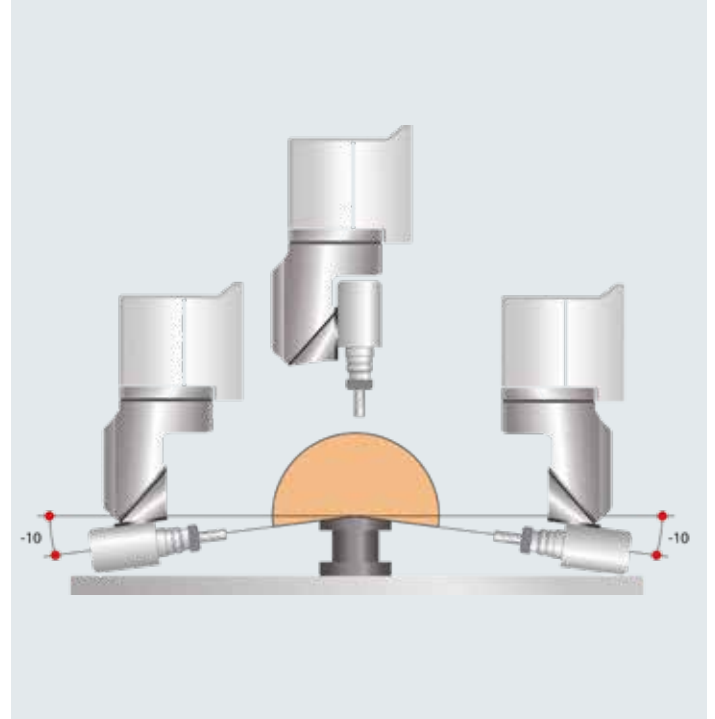

Reduced maintenance and maximum flexibility with the BEL.TECH technology (Belt Technology system), the belt transmission system which eliminates vibration and heat from tools to the motor.

This particular geometrical configuration enables to work on horizontal axis in reduced space.



Guaranteed accuracy of the 5-axis with the RTCP setting (Rotation Tool Center Point system) that automatically re-adjust the machining head parameters through a self-calibration system and a software function available on the machine, developed by SCM.

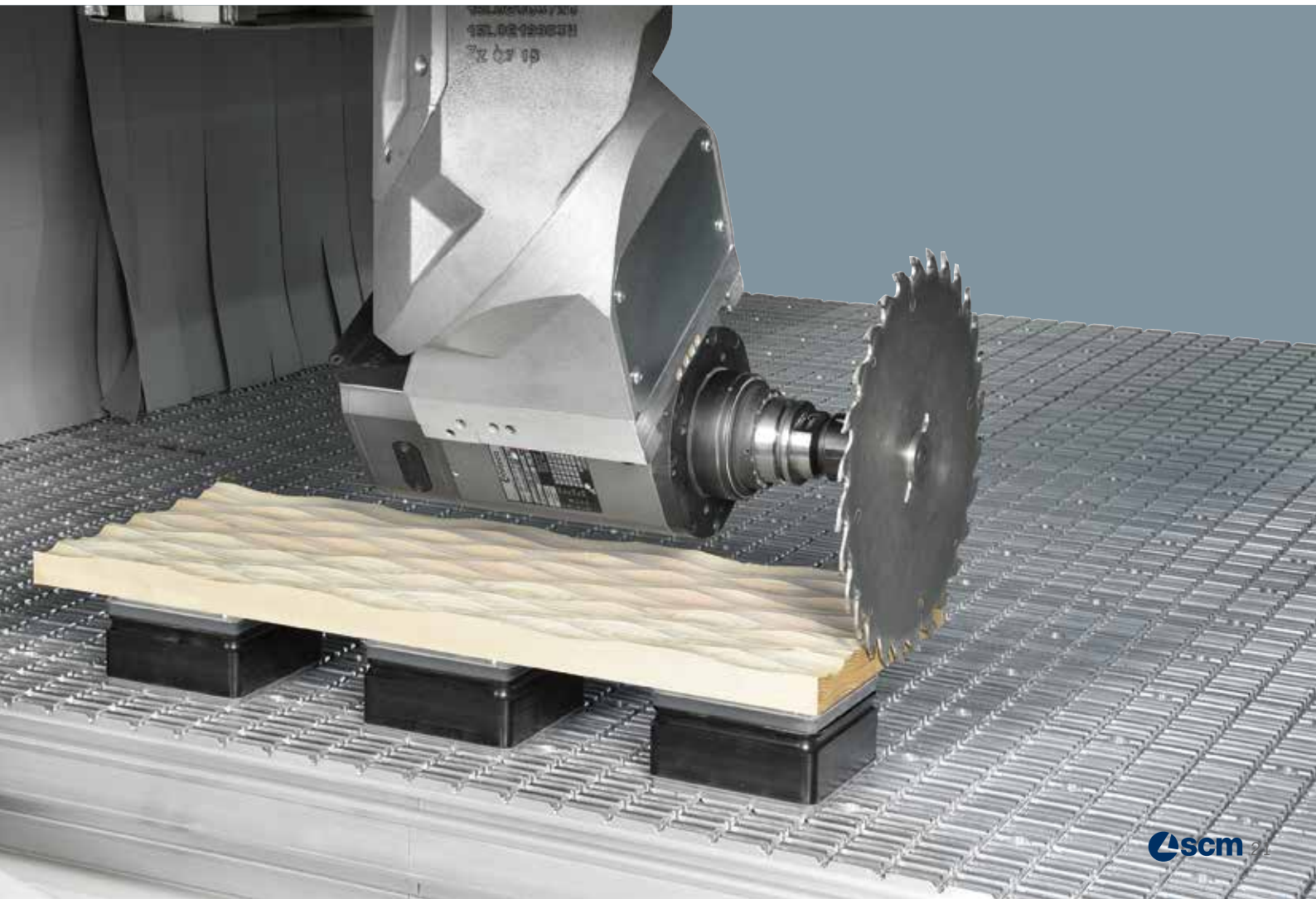
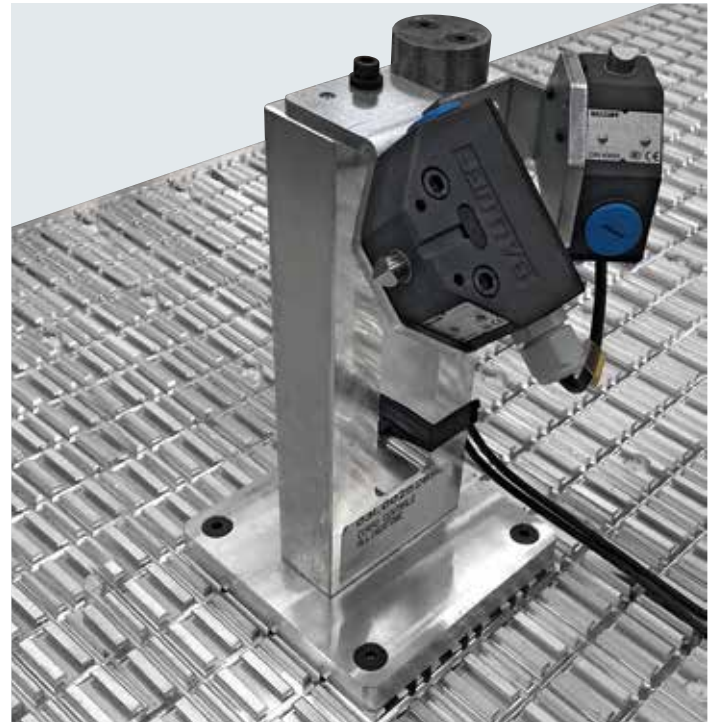

MACHINING UNIT

TWIN MACHINING HEAD

Very high productivity thanks to the new combined machining head with 3 and 5 independent axes.

The alternate use of the two routing units reduces the cycle time: while one unit is working, the other performs the tool change in masked time.

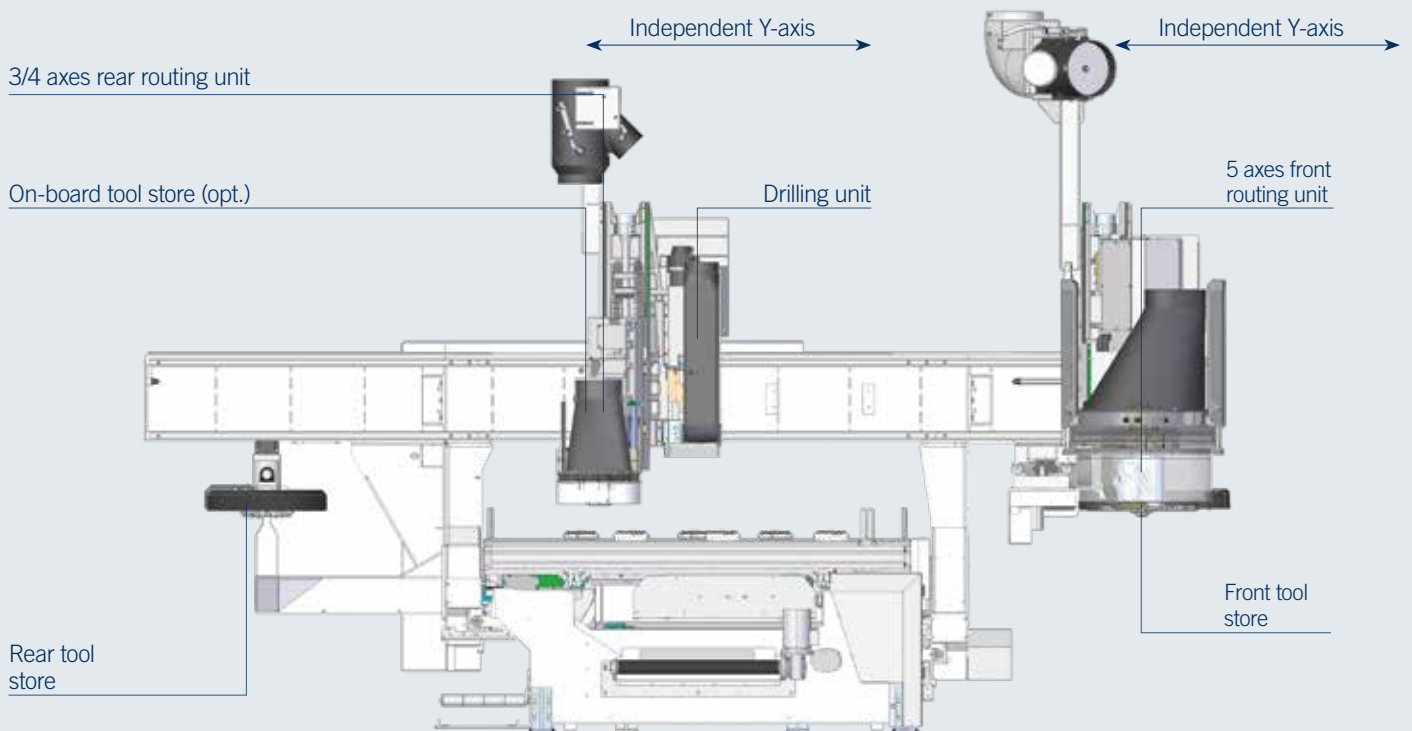

BRC WORKING UNIT

Boring, Routing and Cutting both vertically and horizontally, **without needing to tool change.**

Fast and efficient, all additional machinings are carried out by this unit that has an independent Z-axis and a dedicated inverter.



MACHINING UNIT



The traditional solution with sturdy carriage directly fitted to the vertical guides. Wide range of high power electrospindles to use large dimensioned tools and double-profile tools.

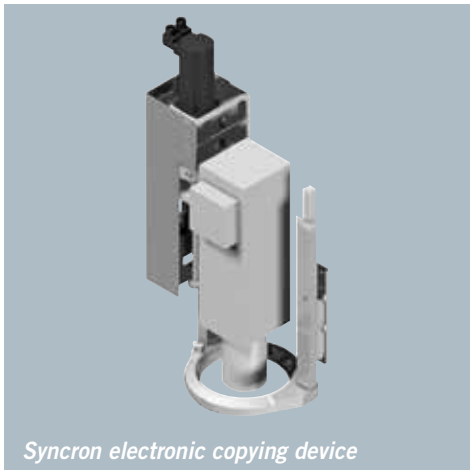

Synchron electronic copying device

This device ensures milling of the top surface of the work-piece at constant-depth through the synchronised movement of the Z-axis.



Coaxial mechanical presser

It is essential to hold down small work-pieces.



RO.AX SPINDLE

Zero play during machining with the new RO.AX technology (RotoAxial spindle technology), the most efficient spindle on the market with rotation speeds up to 8000 rpm.

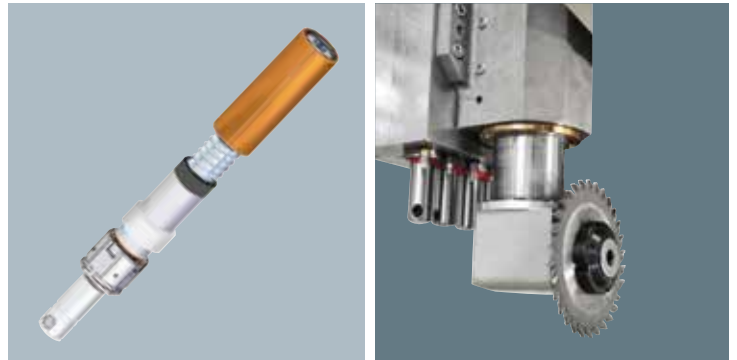

A dedicated saw-blade unit is available for cuttings, either in fixed position or with 0-90° adjustable angle.

DRILLING UNIT

Optimum solution to any drilling needs thanks to the wide range of modules, equipped with independent vertical and horizontal spindles.

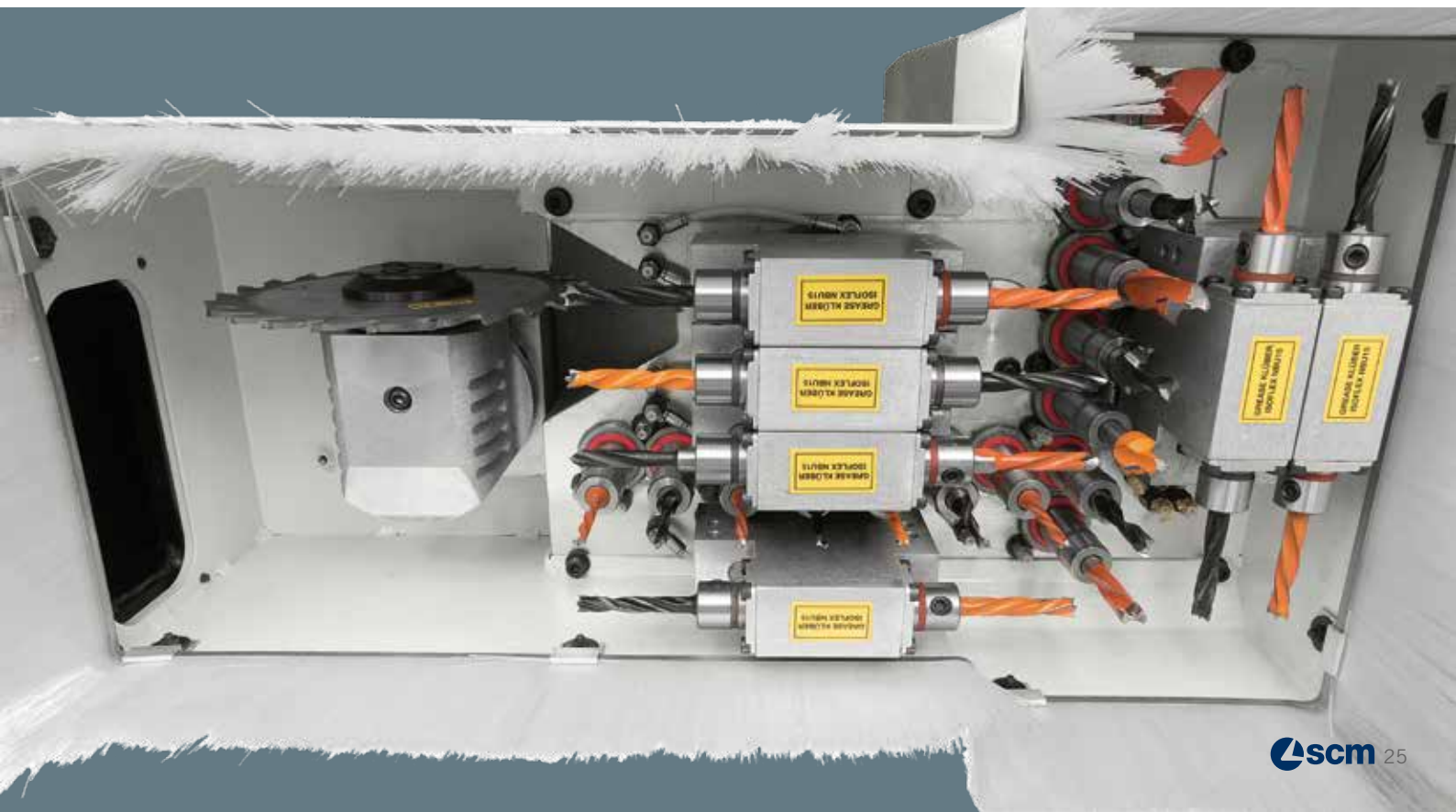

CLEANING SYSTEM

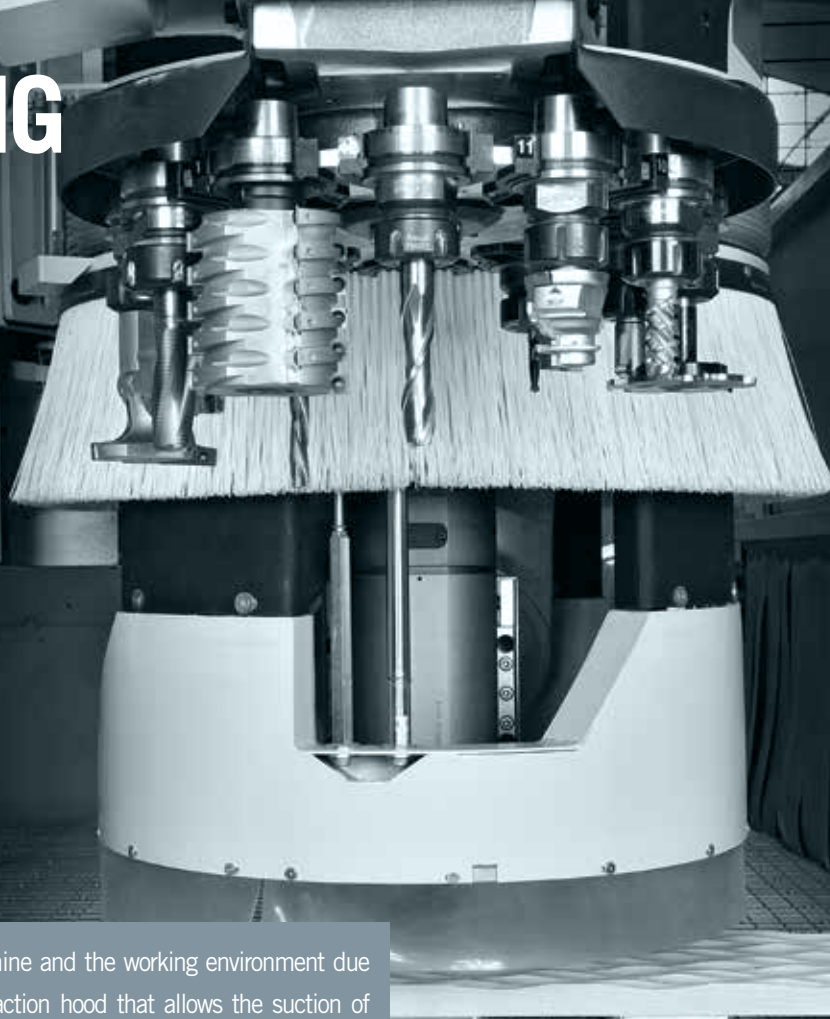

Maximum cleaning of the machine and the working environment due to the double coaxial dust extraction hood that allows the suction of shavings and sawdust in any condition of use.



The inner hood is used for routing with the tool in vertical position, due to its reduced dimensions.



The outer hood is used during 5 axes routing operations, as it has adequate dimensions to cover all tool movements.



The coaxial deflector is particularly useful during machining with tools in vertical position and heavy stock removal. It is automatically directed towards dust extraction inlets.

TOOL STORES



TRC 48 or 32 positions

Chain tool store anchored to the mobile gantry structure, developed for managing heavy and large tools, ideal for the processing of solid wood.



MACH 5

In only five seconds, it replaces the tool drastically reducing down-times.



RAPID
24 or 16 positions

Circular tool store anchored to the mobile gantry structure, to have the most tools available.



RAPID 12 ON-BOARD
12 positions

Circular tool store located on the machining head, it allows the tool change during drilling operations.



TR 12
12 positions

Maximum efficiency with the side tool store positioned on the right side of the worktable.

BARS WORKTABLE

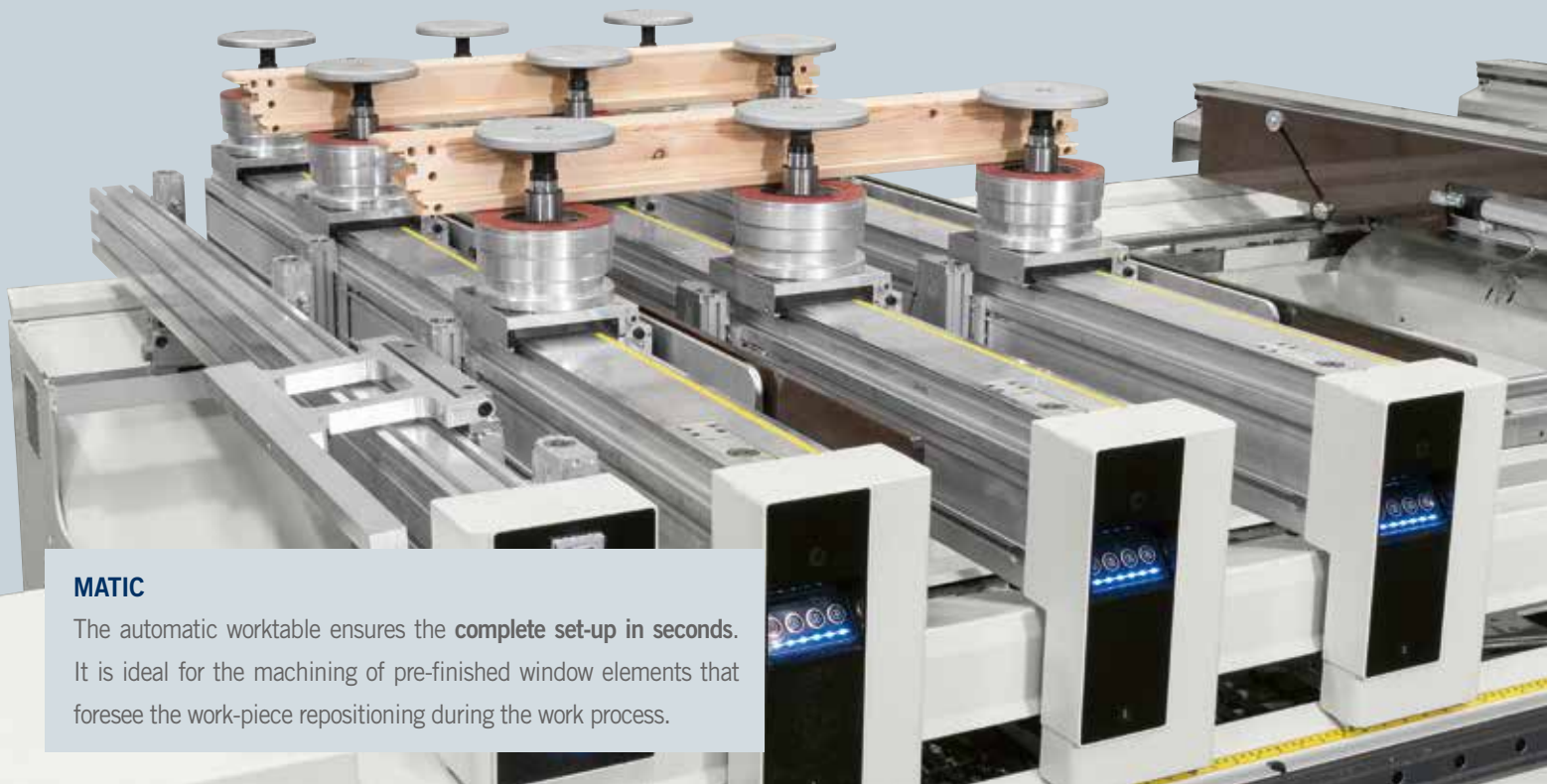

MATIC

The automatic worktable ensures the **complete set-up in seconds**. It is ideal for the machining of pre-finished window elements that foresee the work-piece repositioning during the work process.

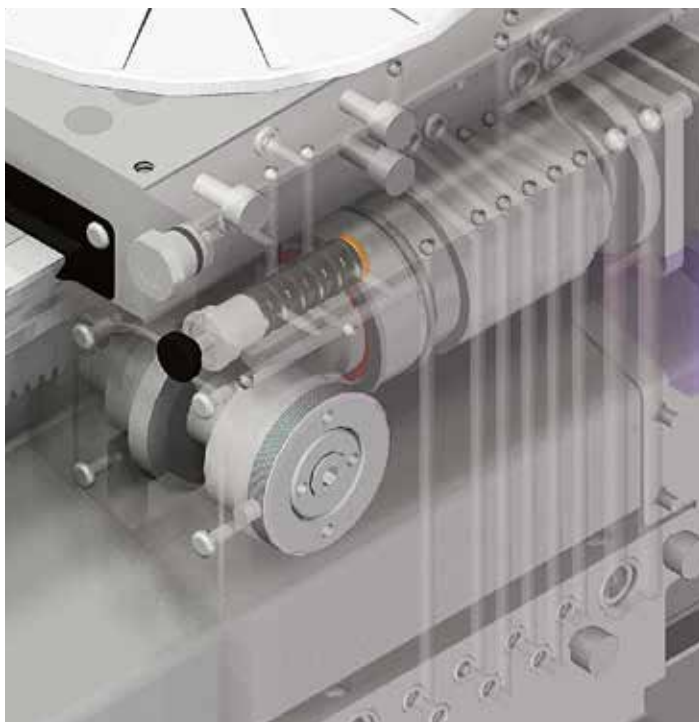

Bars and bases are moved using a rack-and-pinion direct transmission system and have independent drive units.



Locking clamps with 145 mm height (H145) to process elements of different thickness by using double-profile tools, from 60 to 120 mm, without any need of manual adjustments.



Simple and quick replacement of clamps and suction cups by pressing a button, through the exclusive rapid locking device.



*Easy and ergonomic work-pieces loading and unloading, automatic movement of the parts to the machining zone avoiding any type of collision, thanks to **worktable total management**. Cleaning is carried out by using **blowing systems** that remove shavings both from the sliding area and the work-piece supporting surface.*



BARS WORKTABLE



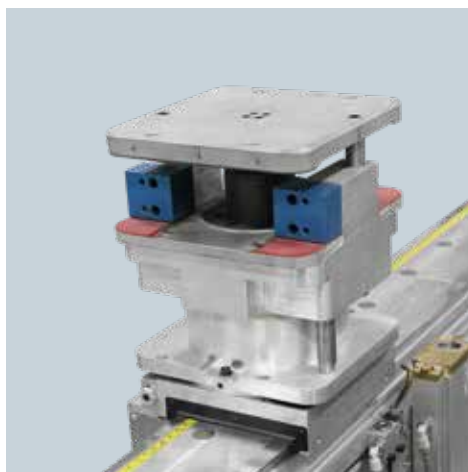
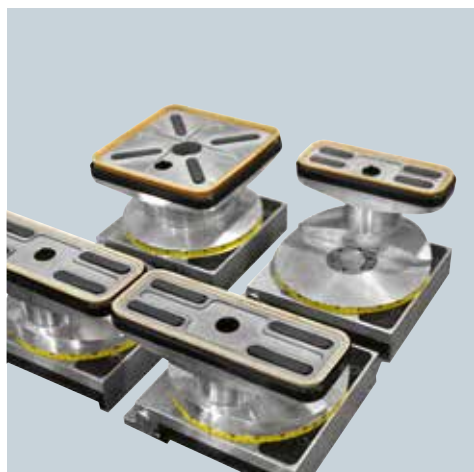
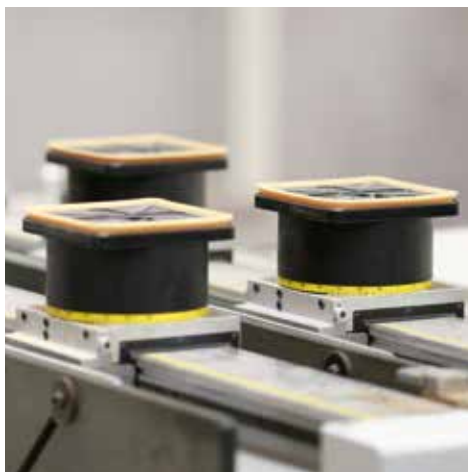

Wide range of accessories that ensures an optimal work-piece locking to always reach the best finish quality even with heavy stock removal.

START

Maximum freedom of use with the manual action worktable: the pneumatic locking of clamps or suction cups can be used on each movable bar, for machining elements having different shape and size.



MULTI-FUNCTION WORKTABLE



MULTI-FUNCTION WORKTABLE

The SCM aluminium worktable guarantees **best reliability**. Characterized by a perfect lasting planarity, it is not subject to warping due to changes in ambient factors such as temperature and humidity.



The vacuum system is formed directly within the extruded aluminium parts and distributed on a grid of holes spaced at 120 mm on the whole surface of the worktable.

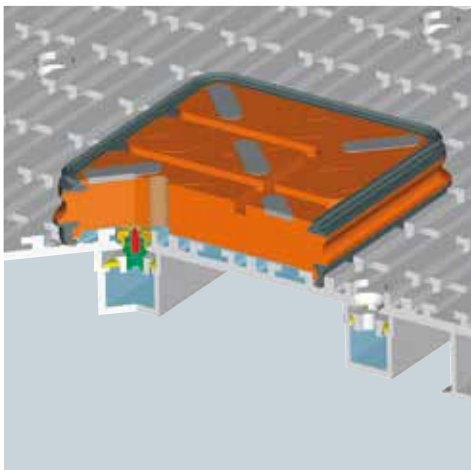



On the entire surface of the worktable there are **T-grooves** that allow the firm locking of any additional equipment not supplied by SCM.

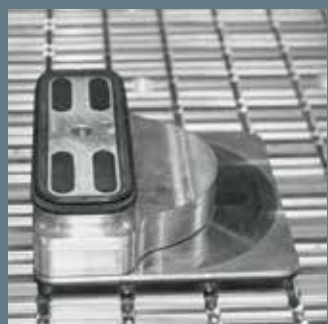

It is possible to configure the worktable with different types of MPS suction cups, adding or removing them easily, depending on the type and geometry of the pieces to be fixed. The laser pointer helps the operator to quickly reach the correct set-up.

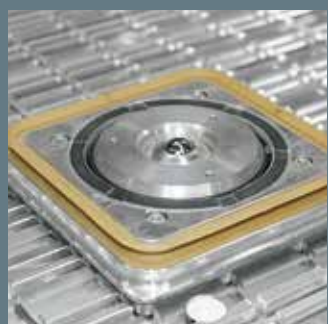

500 MM WORKING HEIGHT ACCORD 50 FX/FXM



The sturdy machine's structure and the architecture of the machining unit enable the tool to **move freely around parts of complex shape**, and perform three-dimensional machining with high precision and maximum finish quality.

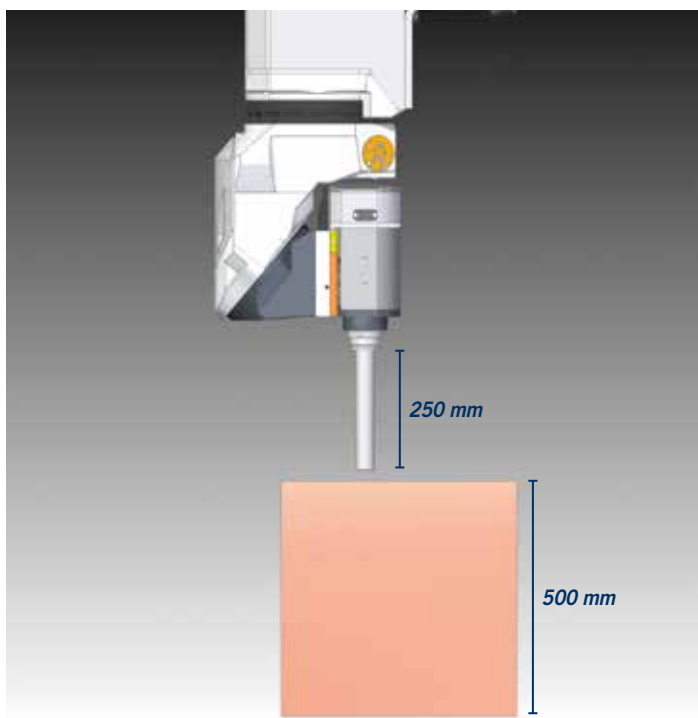

Large working volume thanks to the increased Z-axis stroke allowing the machining of work-pieces up to 500 mm in height, using large dimensioned tools.



AUTOMATIC LOADING AND UNLOADING SYSTEM

ACCORD WD



Several elements of different length can be positioned on the loading table. When the operator loads the element, its dimensions (length, width, thickness) are checked with an optical laser.

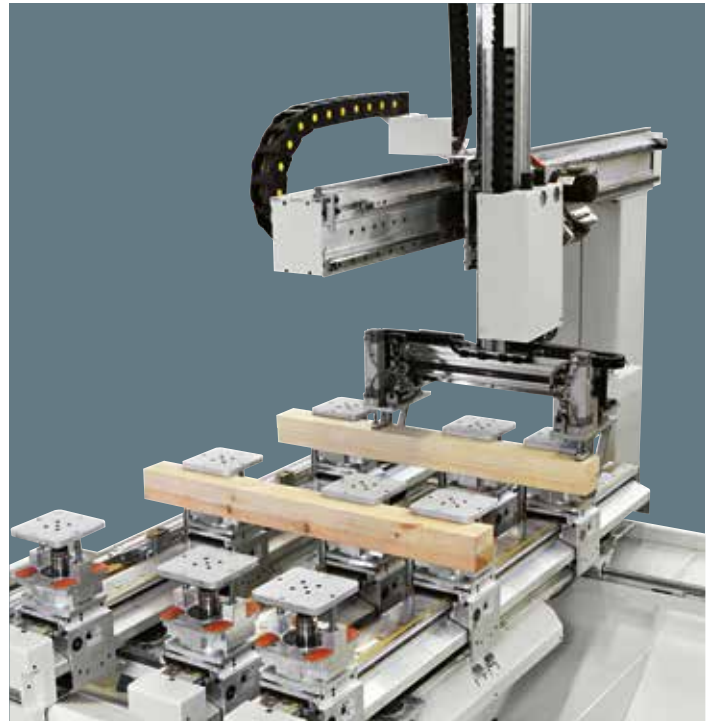

For increased productivity, two elements can always be machined at the same time on the half-worktable.



Short elements are loaded automatically and locked with a single clamp.

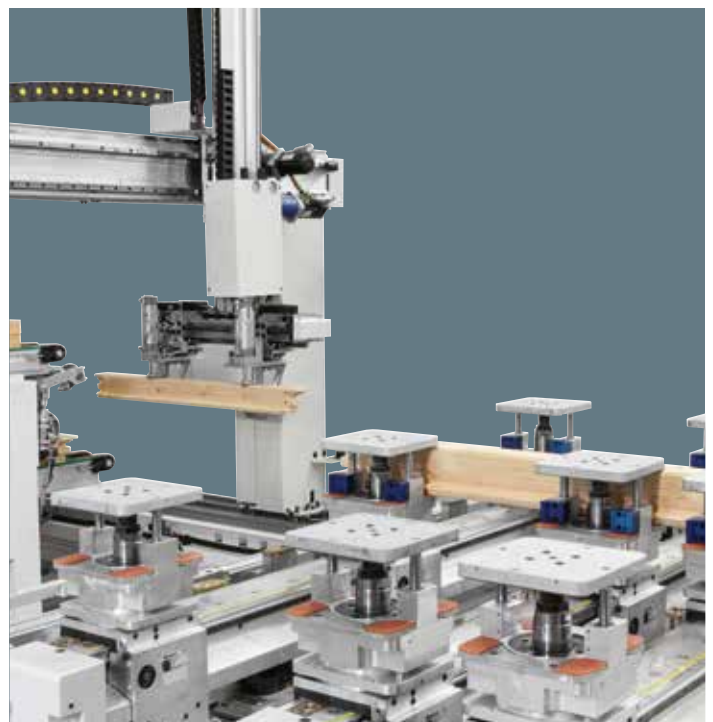

The handling units setting is managed by NC controlled axes. The clamping grippers are automatically positioned, according to the length and width of the work-pieces.



AUTOMATIC LOADING AND UNLOADING SYSTEM

ACCORD WD

1

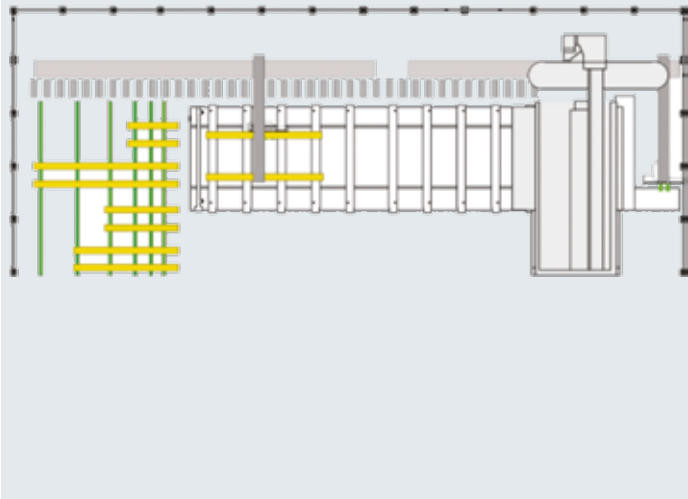

The left handling unit picks up the blanks elements from the loading table (upper deck) and deposits them on the left half-worktable.

2

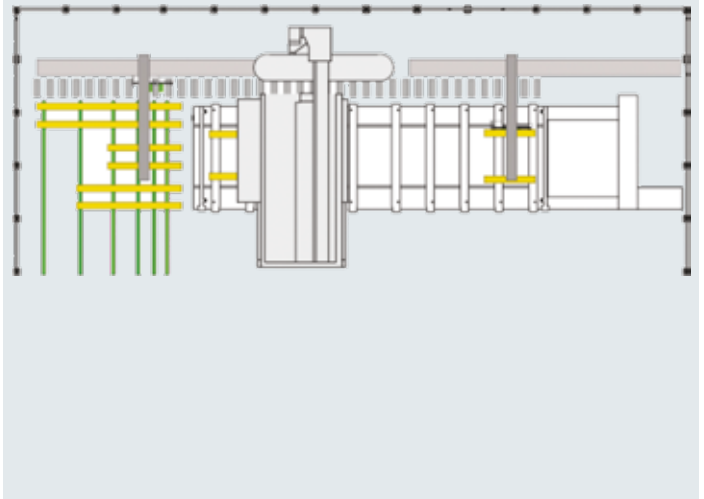

While the machine executes the program on the left half-worktable, the right handling unit receives the next blanks elements from the rear roller conveyor and deposits them on the right half-worktable.

3

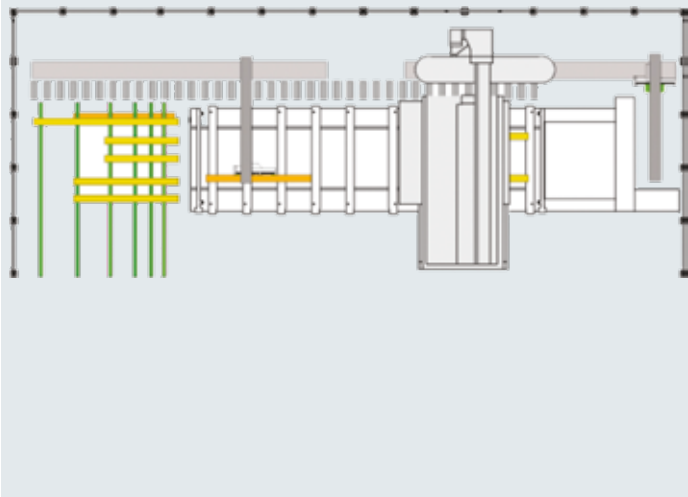

Once the program is finished, the left handling unit unloads all the finished elements from the left half-worktable and deposits them on the unloading table (lower deck).

4

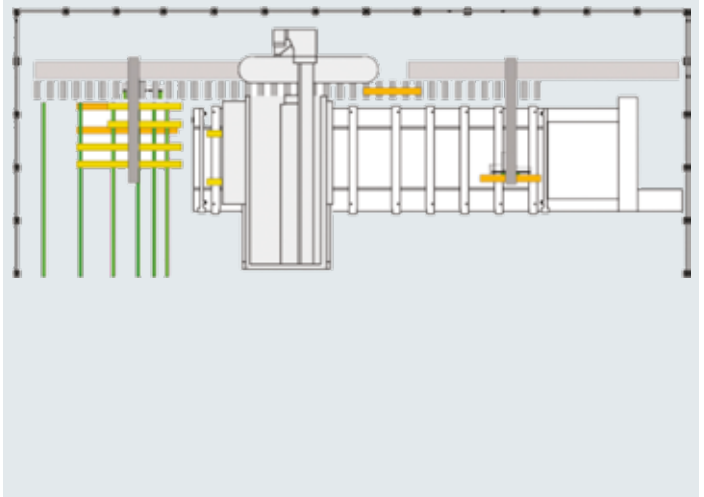

The cycle is completed by unloading the elements from the right half-worktable, while the machine is already processing the next elements on the left half-worktable.

Maximum flexibility to process special window and door frames or other types of elements as the worktable can be accessed also for manual loading and unloading.

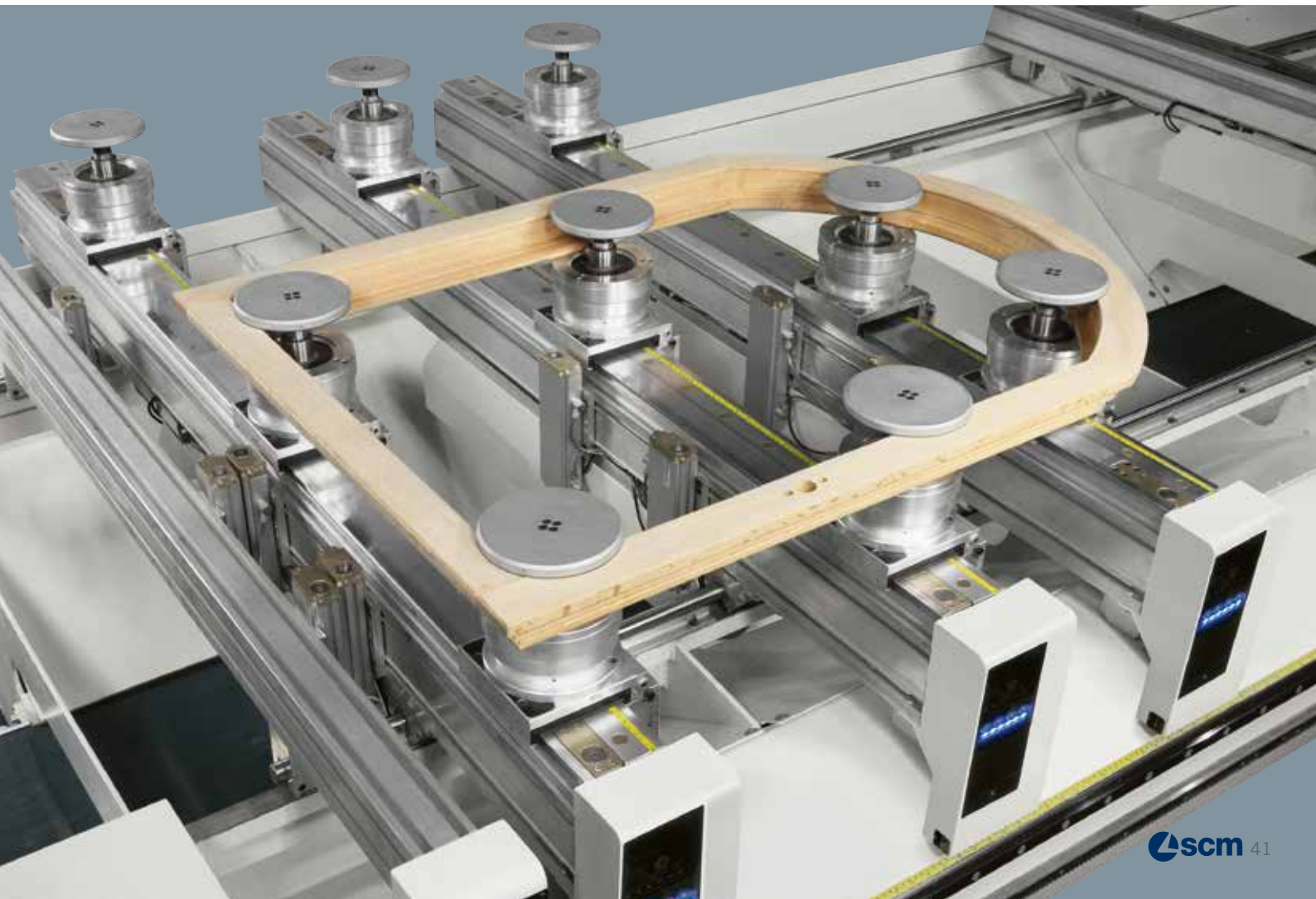

M Maestro Digital Systems

SMART SOFTWARE AND DIGITAL SERVICES TO ENHANCE PRODUCTIVITY OF WOODWORKING AND FURNITURE INDUSTRIES.

design



programming
and data
generation

Maestro office

Office



Factory

Maestro active

cutting



routing
drilling

SOFTWARE

Simple, smart and open.

Maestro software are tailored on the machine technology as well as on the entire process. All Maestro software share a common mission:

easy to use, so that any operator can easily and confidently learn and use the software

smart, with algorithms and computing modules aiming at the best possible result

open in order to integrate existing software, and provide customer the coverage of all his process.



SCM accompanies woodworking companies throughout their whole process combining machines with matching software solutions and digital services, with a constant strive to enhance company productivity.

The software solutions powered by SCM are developed to optimize machine usage as well as the entire process, providing integration with the different software existing in the company.

DIGITAL SERVICES

Transforming the way it delivers services to its customers through digital technologies and particularly, the IoT platform that collects and analyses data coming from the machine, **SCM created a world of services enabled by Maestro connect.**

Meaning that connecting an SCM machine through Maestro connect will let customer subscribe a program of fast-evolving services and access a wide range of benefits that even go beyond the machine experience and will support and assist you through the whole life-cycle of your machine.

Maestro connect IoT Platform

1
Machine monitoring,
KPIs, early warning

2
Maintenance
equipment

3
Predictive
maintenance

4
Report and historical
data export to MES

5
Warranty
extension

6
Augmented remote
support

7
Smart learning,
SELF-HEALING,
video tutorials

8
Asset management
with e-shop SCM
Spare Parts





Maestro cnc

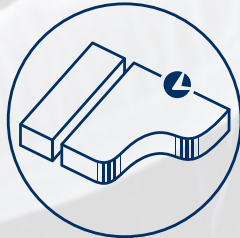

In the office, before the production, the design and programming system Maestro cnc ensures that routing, drilling or sawing can quickly and easily be programmed thanks to 3D graphics of work-pieces and machining and clamping aids as well as a smart App and macros library to program any machine operation with a mouse click. Another click away and CNC programs are automatically generated.

SOFTWARE

Office

Maestro cnc

THE SOFTWARE THAT SIMPLIFY THE WORK

CAD/CAM programming software to design all the production processes. Developed in Windows® environment it ensures easy programming with an advanced, simple and intuitive sketching that features all the tools necessary to design the parts, their layout on the worktable, tools management and the relative machining operations. All the procedures are contained in a perfectly integrated and high performance software.

ADDITIONAL FUNCTIONS



Maestro pro view - Unique 3D display

3D Simulator that allows users access to a three dimensional model of their machine in their office and view the operations that will be carried out during the production in advance on their PC.



Maestro 3d - Unique in the creation of 3D objects

Integrated module designed to program three dimensional objects on 5 axes machining centres.



Maestro apps - Unique know-how

Maestro apps is a library of programming functions that are always available and easy to use, developed by SCM for the production of parts for doors, windows, stairs, furniture and furnishings.



Maestro msl connector - Total integrability

Connector for third-parties with design software.



Maestro active cnc

Maestro active is the new operator interface software which has been unified across all SCM technologies. A single operator can easily and confidently run multiple machines due to controller and interface consistency: regardless the machine, Maestro active maintains the same *look&feel*, with many identical icons and navigation buttons, thus ensuring the same approach to interaction.

EASE OF USE

The new interface has been specifically designed and optimized for immediate use via touch screen. Graphics have been redesigned for simple and comfortable navigation, with tablet-like icons on touch screen controller.

“ZERO” ERRORS

Improved productivity thanks to integrated help and recovery procedures that reduce the possibility of error from the operator’s side.

SOFTWARE

Factory

Maestro active cnc

A REVOLUTIONARY APPROACH TO INTERACT WITH YOUR SCM MACHINE

FULL CONTROL OF PRODUCTION PERFORMANCES

The creation of customizable reports by operator, shift, program, forecast period (and much more) allows to monitor, optimize and improve the production performance.

FULL MACHINE AWARENESS AND KNOWLEDGE MANAGEMENT SYSTEM

Maestro active allows to record the times related to set-up, maintenance, training and other events, tracing all the activities in a database. The operator’s *know-how* is also stored and made available to other people inside the organization thanks to the possibility to comment and document all production events or notifications.

ORGANIZE YOUR PRODUCTION

Maestro active allows to create different users with different roles and authorizations (e.g.: operator, maintainer, administrator, ...). Any user can only execute the functions whose permissions have been assigned to him. It is also possible to define the work shifts on the machine and then detect activities, productivity and events that occurred in each shift.

TOTAL QUALITY OF THE FINISHED PRODUCT

With Maestro active the quality of the finished piece is no longer put at risk by worn tools. The new Maestro active Tool Life Determination system sends notification messages as the tool reaches its end of life and recommends its replacement at the most appropriate time.

TOOLS? NO PROBLEM!

Maestro active guides the operator during the tool change phase, taking into account the programs to be executed.

A WORLD OF SERVICES FOR GREATER EFFICIENCY

Maestro connect

CONNECT YOUR MACHINE AND GAIN ACCESS TO A WORLD OF SERVICES

Connecting your machine through IoT technology Maestro connect will let you subscribe a program of fast-evolving services. You will access a wide range of benefits that even go beyond the machine experience and will support and assist you through the whole life-cycle of your machine.

FASTER SERVICE INTERVENTION AND PROBLEM RESOLUTION

Maestro connect provides real time data and Health Records of the machine also to SCM Service, drastically reducing its troubleshooting time.

WORKING ALWAYS IN PERFECT CONDITIONS

Maestro connect can provide a full kit of sophisticated sensor devices to detect and warn the operator in case of alarming conditions of the machine.

DIGITAL SERVICES

SMART MAINTENANCE: DOWN TIME REDUCTION

Maestro connect reduces maintenance downtime thanks to:

- automatic maintenance notifications and scheduling, to prevent failures and work in the best conditions of use
- direct connection to SCM Service thanks to an automatic ticket opening function

SMART MACHINE: ANYTIME, ANYWHERE, AWARENESS

Connecting your SCM machine also means having your machine always at hand.

Immediate instant notifications in case of alarms or downtimes allow customers to immediately take an action thus optimizing his productivity.

SMART MANAGEMENT: PRODUCTION PERFORMANCE OPTIMIZATION

Reports and KPIs allow further analysis thus increasing customer knowledge about his performance and results.

SMART PARTS: FAST PARTS REPLENISHMENT

Repairs are scheduled proactively since the system provides Spare Parts suggestions and a direct Integration with Smart Parts e-shop.

SMART LEARNING: EXECUTE WORK AND RECEIVE PROBLEM SOLVING SUPPORT

Maestro connect provides an intuitive problem solving management system to help the operator to self solve any issue.

SMARTECH: FASTER AUGMENTED SUPPORT

Maestro connect allows augmented reality support by means of Smartech: the head-wearable computers with wireless connectivity that will bring the interaction between customer and SCM service to a higher level.

SMART WARRANTY: YOUR MACHINE ALWAYS IN PERFECT CONDITIONS

Together with scheduled maintenance contracts, you can take care of your asset by doubling the warranty from 1 year to 2 years* for complete peace of mind!

* please read the complete contract to understand terms and conditions.

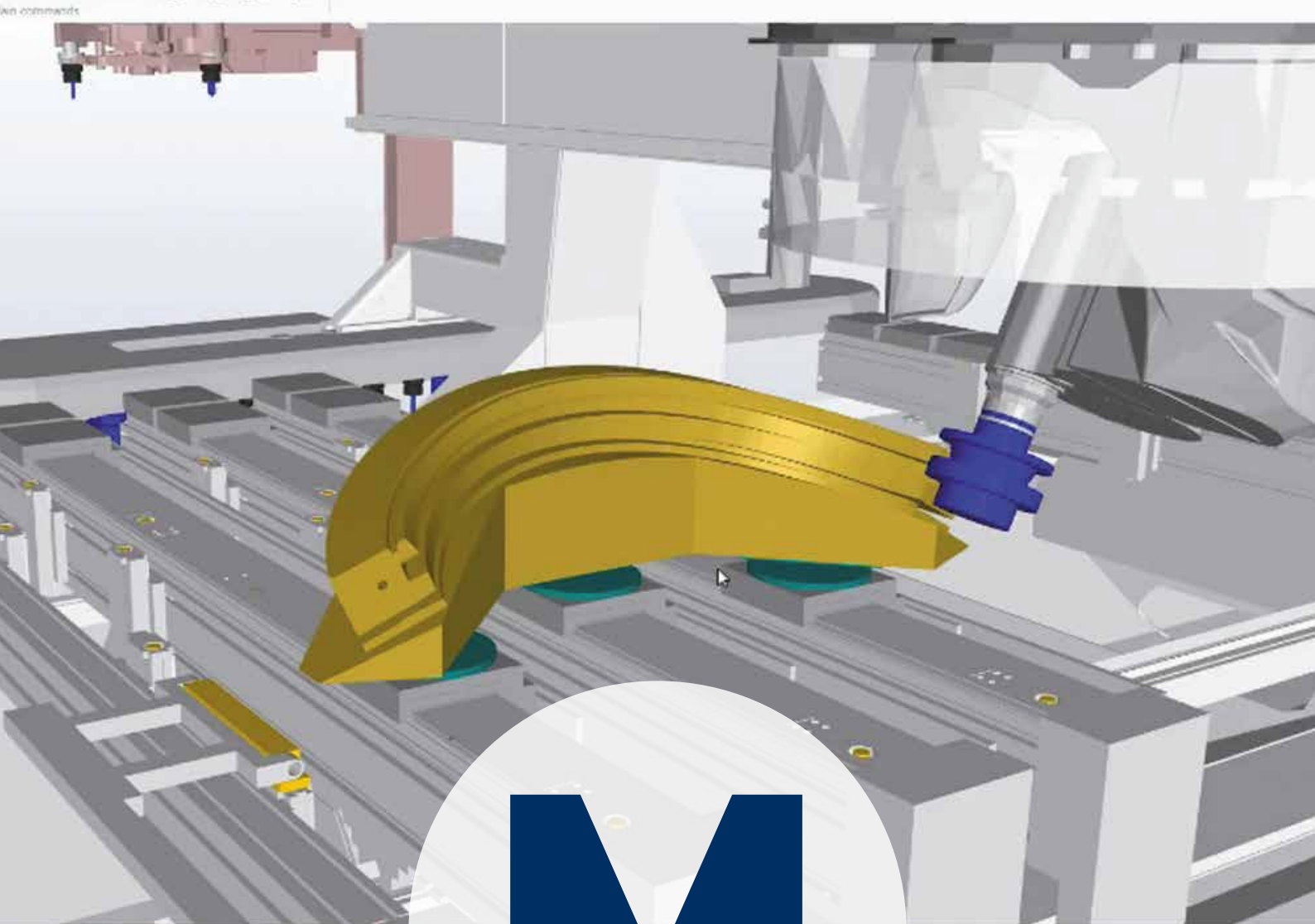

SAFETY SYSTEMS



The machining head cover is equipped with compact bumper protections, enabling the use of the entire work area, and the positioning of several pieces on the worktable all at the same time.

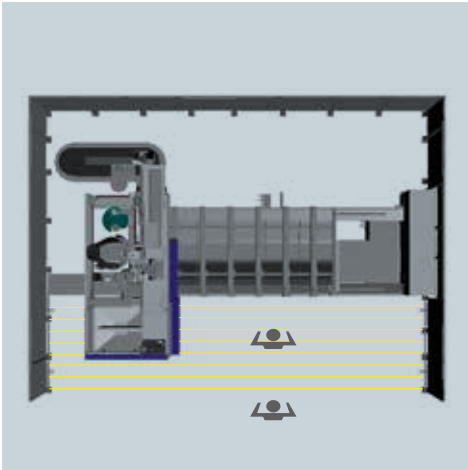

PRO-SPEED

The safety system with horizontal photocells and bumper protections, combines total access to the worktable and maximum operator's safety during work-piece loading and unloading.

When machining, the top speed can be reached for higher productivity.

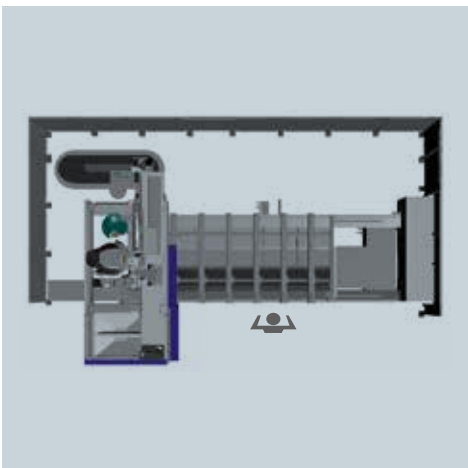

PRO-SPACE

Designed to minimise the machine footprint while guaranteeing maximum operator's safety thanks to the bumper protections installed on the mobile gantry structure.

During machining, the speed is limited to max. 25 m/min.

| | ACCORD 25 | ACCORD 40 | ACCORD 42 | ACCORD 50 | ACCORD WD |
|--|-----------|-----------|-----------|-----------|-----------|
| PRISMA 5 axes machining head | ✓ | ✓ | ✓ | ✓ | ✓ |
| TWIN machining head | - | - | ✓ | - | - |
| 3 axes machining head | ✓ | ✓ | ✓ | - | - |
| BRC working unit | - | ✓ | - | - | ✓ |
| BRC-K working unit | ✓ | - | - | - | - |
| Drilling unit | ✓ | ✓ | ✓ | ✓ | - |
| Deflector on electrospindle | ✓ | ✓ | ✓ | ✓ | ✓ |
| MACH 5 tool change device | - | ✓ | - | - | - |
| TRC 48 tool store | - | ✓ | ✓ | ✓ | ✓ |
| TRC 32 tool store | ✓ | - | - | ✓ | - |
| RAPID 24 tool store | ✓ | ✓ | - | ✓ | - |
| RAPID 16 tool store | ✓ | ✓ | ✓ | ✓ | - |
| RAPID 12 ON-BOARD tool store | ✓ | ✓ | ✓ | ✓ | ✓ |
| TR 12 tool store | ✓ | ✓ | - | ✓ | ✓ |
| Automatic loading and unloading system | - | - | - | - | ✓ |

ELECTROSPINDLES POWER

The wide range of electrospindles, designed and manufactured by SCM, develops an output of 21 kW and reaches maximum rotation speed of 24000 rpm.

Excellent performances for routing with heavy stock removal and profiling at high rotation speed.

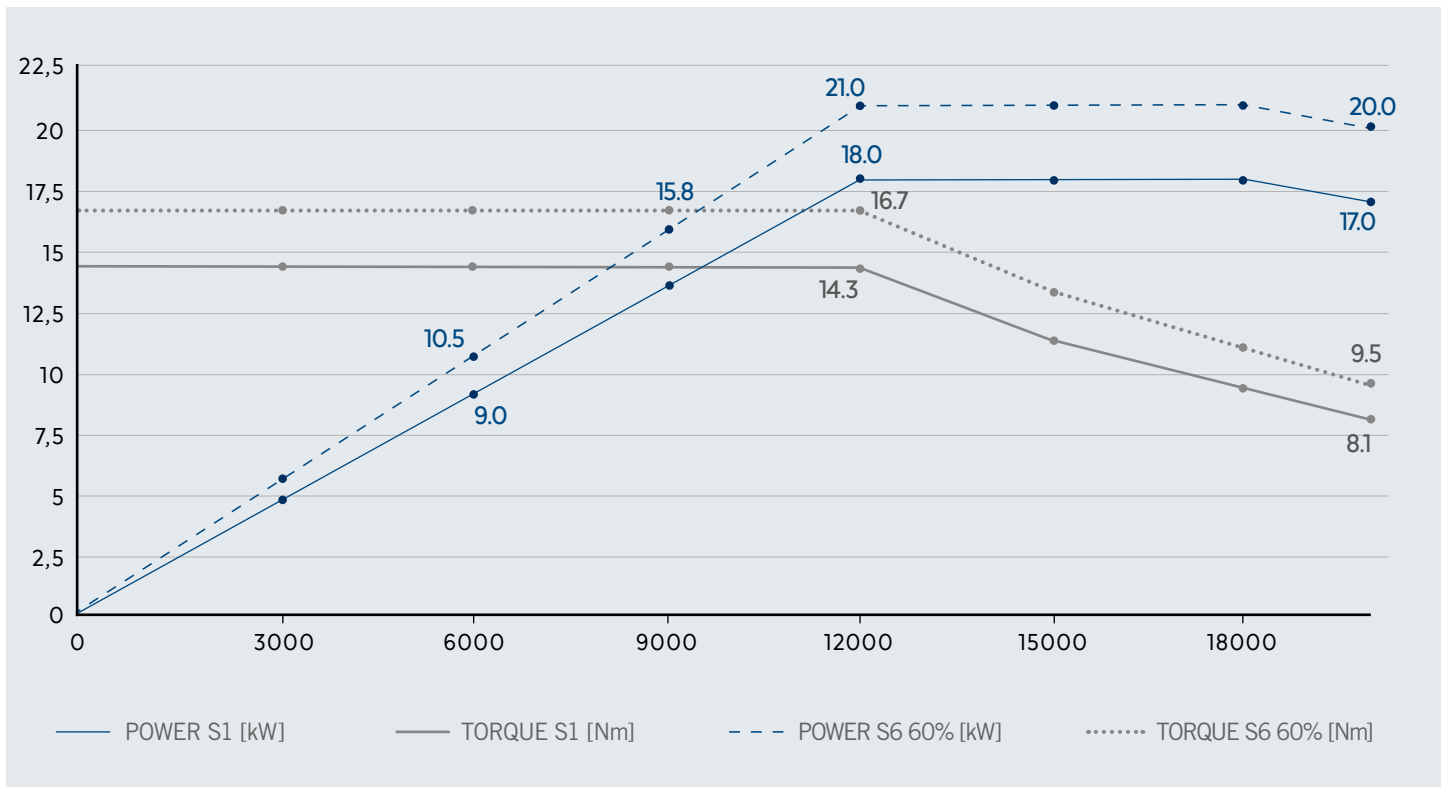

OVERALL DIMENSIONS AND LAYOUT BARS WORKTABLE

| X-Y-Z WORKING AREA | | PRO-SPEED | | PRO-SPACE | |
|---------------------|----|-----------|------|-----------|------|
| | | A | B | B | C |
| ACCORD 25 FX | | | | | |
| 3680 x 1380 x 250 | mm | 7550 | 5100 | 4240 | 2850 |
| 5020 x 1380 x 250 | mm | 8880 | 5100 | 4240 | 2850 |
| 6360 x 1380 x 250 | mm | 10220 | 5100 | 4240 | 2850 |
| 3680 x 1680 x 250 | mm | 7550 | 5500 | 4570 | 2850 |
| 5020 x 1680 x 250 | mm | 8880 | 5500 | 4570 | 2850 |
| 6360 x 1680 x 250 | mm | 10220 | 5500 | 4570 | 2850 |
| ACCORD 40 FX | | | | | |
| 3680 x 1680 x 350 | mm | 8520 | 5960 | 5250 | 3000 |
| 5020 x 1680 x 350 | mm | 9820 | 5960 | 5250 | 3000 |
| 6360 x 1680 x 350 | mm | 11250 | 5960 | 5250 | 3000 |
| 3680 x 1905 x 350 | mm | 8520 | 6355 | 5465 | 3000 |
| 5020 x 1905 x 350 | mm | 9820 | 6355 | 5465 | 3000 |
| 6360 x 1905 x 350 | mm | 11250 | 6355 | 5465 | 3000 |
| ACCORD 42 FX | | | | | |
| 5020 x 1680 x 350 | mm | 9930 | 6720 | 5760 | 3150 |
| 6360 x 1680 x 350 | mm | 11270 | 6720 | 5760 | 3150 |
| 5020 x 1905 x 350 | mm | 9930 | 6950 | 5990 | 3150 |
| 6360 x 1905 x 350 | mm | 11270 | 6950 | 5990 | 3150 |
| ACCORD 50 FX | | | | | |
| 3680 x 1680 x 500 | mm | 8440 | 5700 | 4670 | 3600 |
| 5020 x 1680 x 500 | mm | 9850 | 5700 | 4670 | 3600 |
| 6360 x 1680 x 500 | mm | 11130 | 5700 | 4670 | 3600 |
| 3680 x 1905 x 500 | mm | 8440 | 5940 | 4890 | 3600 |
| 5020 x 1905 x 500 | mm | 9850 | 5940 | 4890 | 3600 |
| 6360 x 1905 x 500 | mm | 11130 | 5940 | 4890 | 3600 |
| ACCORD WD-A | | | | | |
| 3680 x 1905 x 350 | mm | 11820 | 6550 | - | 3000 |
| ACCORD WD-B | | | | | |
| 6360 x 1905 x 350 | mm | 14590 | 6550 | - | 3000 |

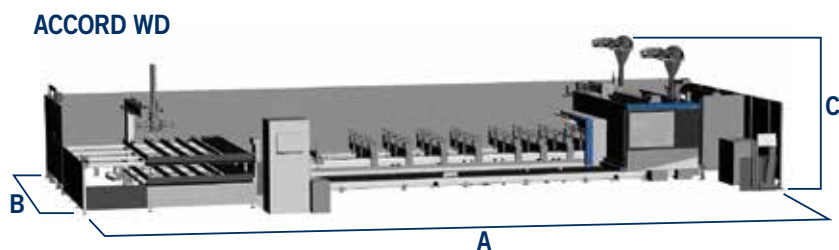

OVERALL DIMENSIONS AND LAYOUT

MULTI-FUNCTION WORKTABLE

accord range
numeric control machining centres

| X-Y-Z WORKING AREA | | PRO-SPEED | | PRO-SPACE | |
|----------------------|----|-----------|------|-----------|------|
| | | A | B | B | C |
| ACCORD 25 FXM | | | | | |
| 3650 x 1320 x 250 | mm | 7550 | 5100 | 4240 | 2850 |
| 4970 x 1320 x 250 | mm | 8880 | 5100 | 4240 | 2850 |
| 6170 x 1320 x 250 | mm | 10220 | 5100 | 4240 | 2850 |
| 3650 x 1600 x 250 | mm | 7550 | 5500 | 4570 | 2850 |
| 4970 x 1600 x 250 | mm | 8880 | 5500 | 4570 | 2850 |
| 6170 x 1600 x 250 | mm | 10220 | 5500 | 4570 | 2850 |
| 3650 x 2120 x 250 | mm | 7550 | 6100 | 5110 | 2850 |
| 4970 x 2120 x 250 | mm | 8880 | 6100 | 5110 | 2850 |
| 6170 x 2120 x 250 | mm | 10220 | 6100 | 5110 | 2850 |
| ACCORD 40 FXM | | | | | |
| 3650 x 1600 x 350 | mm | 8520 | 5960 | 5250 | 3000 |
| 4970 x 1600 x 350 | mm | 9820 | 5960 | 5250 | 3000 |
| 6170 x 1600 x 350 | mm | 11250 | 5960 | 5250 | 3000 |
| 3650 x 2120 x 350 | mm | 8520 | 6500 | 5650 | 3000 |
| 4970 x 2120 x 350 | mm | 9820 | 6500 | 5650 | 3000 |
| 6170 x 2120 x 350 | mm | 11250 | 6500 | 5650 | 3000 |
| ACCORD 42 FXM | | | | | |
| 4970 x 1600 x 350 | mm | 9930 | 6720 | 5760 | 3150 |
| 6170 x 1600 x 350 | mm | 11270 | 6720 | 5760 | 3150 |
| 4970 x 2120 x 350 | mm | 9930 | 7295 | 6335 | 3150 |
| 6170 x 2120 x 350 | mm | 11270 | 7295 | 6335 | 3150 |
| ACCORD 50 FXM | | | | | |
| 3650 x 1600 x 500 | mm | 8440 | 5700 | 4670 | 3600 |
| 4970 x 1600 x 500 | mm | 9850 | 5700 | 4670 | 3600 |
| 6170 x 1600 x 500 | mm | 11130 | 5700 | 4670 | 3600 |
| 3650 x 2120 x 500 | mm | 8440 | 6260 | 5100 | 3600 |
| 4970 x 2120 x 500 | mm | 9850 | 6260 | 5100 | 3600 |
| 6170 x 2120 x 500 | mm | 11130 | 6260 | 5100 | 3600 |

ACCORD FX/FXM PRO-SPEED

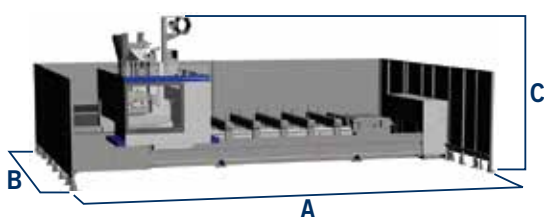

ACCORD FX/FXM PRO-SPACE

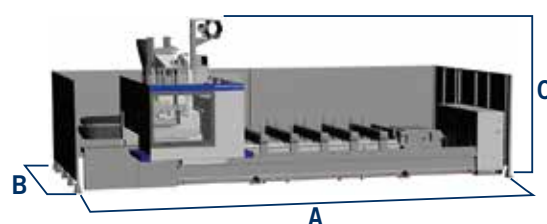

TECHNICAL DATA

| | | ACCORD 25 | ACCORD 40 | ACCORD 42 | ACCORD 50 | ACCORD WD |
|---|-------------------|-----------|-----------|-----------|-----------|-----------|
| AXES | | | | | | |
| X-Y-Z axes max. speed (PRO-SPEED version) | m/min | 60-60-30 | 90-90-30 | 95-90-30 | 95-80-30 | 90-90-30 |
| X-Y-Z axes max. speed (PRO-SPACE version) | m/min | 25-60-30 | 25-90-30 | 25-90-30 | 25-80-30 | – |
| Z axis work-piece passage (max.) | mm | 250 | 350 | 350 | 500 | 350 |
| MACHINING HEAD | | | | | | |
| 5 axes electrospindle motor power (max.) | kW | 12 | 17 | 12 | 17 | 13 |
| 3/4 axes electrospindle motor power (max.) | kW | 15 | 15 | 21 | – | – |
| 5 axes electrospindle rotation speed (max.) | rpm | 24.000 | 24.000 | 24.000 | 24.000 | 18.000 |
| 3/4 axes electrospindle rotation speed (max.) | rpm | 24.000 | 24.000 | 24.000 | – | – |
| DRILLING UNIT | | | | | | |
| Vertical and horizontal spindles (max.) | n. | 30 | 30 | 26 | 26 | – |
| Rotation speed | rpm | 8.000 | 8.000 | 8.000 | 8.000 | – |
| TOOL STORES | | | | | | |
| Tool store on machining head | positions | 12 | 12 | 12 | 12 | 12 |
| Rear tool store | positions | 32 | 48 | 48 | 48 | 48 |
| Side tool store | positions | 12 | 12 | – | 12 | 12 |
| Front tool store | positions | – | – | 16 | – | – |
| INSTALLATION | | | | | | |
| Exhaust air consumption | m ³ /h | 4430 | 4430 | 4430 | 6370 | 4430 |
| Compressed air consumption (min.-max.) | NI/min | 350-550 | 350-550 | 350-550 | 350-550 | 350-550 |



THE USE OF POWER ONLY WHEN IT IS REQUIRED

SavEnergy allows making things operate only when they are really necessary. It means the machine automatically enters "stand-by" mode when there are no panels to be machined.

**COMPANY WITH
QUALITY SYSTEM
CERTIFIED BY DNV GL
= ISO 9001 =**

The technical data can vary according to the requested machine composition. In this catalogue, machines are shown with options. The company reserves the right to modify technical specifications without prior notice; the modifications do not influence the safety foreseen by the CE Norms.

Maximum noise levels measured according to the operating conditions established by EN 848-3:2012
Acoustic pressure in process (routing) 87 dbA (measured according to EN ISO 11202:2010, uncertainty K = 5 dB)
Acoustic power in process (routing) 108 dbA (measured according to EN ISO 3746:2010, uncertainty K = 4 dB)

Even if there is a correlation between above mentioned "conventional" noise emission values and average levels of personal exposure over eight hours of operators, these last also depend on the real operating conditions, duration of exposure, acoustic conditions of the working environment and presence of further noise sources, this means the number of machines and other adjacent processes.



PROMPT AND EXPERT TECHNICAL SUPPORT THROUGH A NETWORK OF 1000 TECHNICIANS AND AN INVENTORY OF 36,000 SPARE PARTS.

HIGHLY SPECIALISED TECHNICIANS, EFFICIENT MANAGEMENT AND 6 SPARE PARTS BRANCHES AROUND THE WORLD GUARANTEE A CLOSE, SAFE AND EFFECTIVE TECHNICAL SUPPORT.

SERVICE

SCM provides a service that goes beyond the purchase, to guarantee the long term performance of your technological production system and peace of mind for your business.

A COMPLETE RANGE OF AFTER-SALES SERVICES

- installation and start-up of machines, cells, lines and systems
- tailored training programs
- telephone support to reduce times and costs when machines are not working
- preventive maintenance programs to guarantee long term performance
- complete renovation of machines and plants to renew the added value of the investments
- custom upgrading to update machines and plants and meet new production requirements

SPARE PARTS

SCM Group can count on 140 spare parts professionals worldwide to meet any request with real time shipments.



36,000 SPARE PARTS

Our spare parts inventory, with a value of 12 million euros, covers every single machine



SPARE PARTS GUARANTEED

We guarantee also hard to find parts, with 3,5 million euros invested in "critical" spare parts.



IMMEDIATE AVAILABILITY

Over 90% of orders received are carried out the same day thanks to the huge inventory available.



6 BRANCHES AROUND THE WORLD

The spare parts service can count on worldwide support (Rimini, Singapore, Shenzhen, Moscow, Atlanta, São Bento do Sul)



500 SHIPMENTS A DAY



THE STRONGEST WOOD TECHNOLOGIES ARE IN OUR DNA

SCM. A HERITAGE OF SKILLS IN A UNIQUE BRAND

Over 65 years of success gives SCM the centre stage in woodworking technology. This heritage results from bringing together the best know-how in machining and systems for wood-based manufacturing. SCM is present all over the world, brought to you by the widest distribution network in the industry.

65 years history

3 main production sites in Italy

300.000 square metres of production space

17.000 machines manufactured per year

90% export

20 foreign branches

350 agents and dealers

500 support technicians

500 registered patents

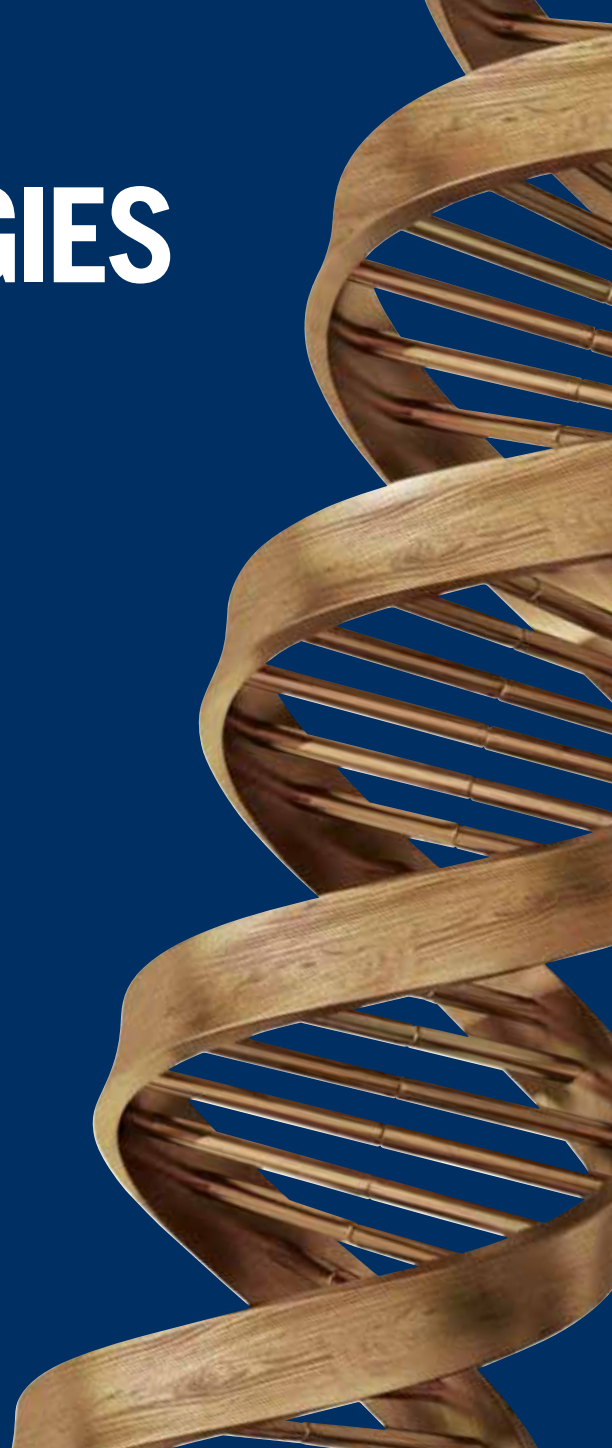

In SCM's DNA also strength and solidity of a great Group. The SCM Group is a world leader, manufacturing industrial equipment and components for machining the widest range of materials.

SCM GROUP, A HIGHLY SKILLED TEAM EXPERT IN INDUSTRIAL MACHINES AND COMPONENTS

INDUSTRIAL MACHINERY

Stand-alone machines, integrated systems and services dedicated to processing a wide range of materials.



WOODWORKING TECHNOLOGIES



TECHNOLOGIES FOR PROCESSING COMPOSITE MATERIALS, ALUMINIUM, PLASTIC, GLASS, STONE, METAL

INDUSTRIAL COMPONENTS

Technological components for the Group's machines and systems, for those of third-parties and the machinery industry.



SPINDLES AND TECHNOLOGICAL COMPONENTS



ELECTRIC PANELS



METALWORK



CAST IRON



is more



SCM GROUP SPA

via Casale 450 - 47826 Villa Verucchio, Rimini - Italy
tel. +39 0541 674111 - fax +39 0541 674274
scm@scmgroup.com
www.scmwood.com



00L0504194A