



# flexstore e/hp

## FAST, RELIABLE AND EASILY INTEGRATED IN THE PRODUCTION FLOW

A wide range of applications can be managed in combination with machines used for nesting cuts, panel sizing machines and automatic labelling systems.

Simple and efficient management of the production to order thanks to the dynamic rationalisation of the distribution and movement of materials performed by the Maestro active store management software developed by SCM.

High levels of productivity and reliability thanks to a sturdy steel structure that allows for high performance levels and the handling of heavy and large components.

- Productivity: up to 500 cycles / shift\*
- Max board dimension: 5.600 x 2.440 mm
- Max weight: 350 kg

Optimisation of the space

The highly modular design of the storage, along with the maximum height of the stack in the storage area, ensures that the space available in the production site is used as effectively as possible.

- Max length: 60 m
- Max width: 16 m
- Max useful stack height: 2.500 mm



**flexstore e1**

Increased quality thanks to the accurate and precise handling of the boards with the pickup table fitted with systems designed specifically to maintain the surface finish.

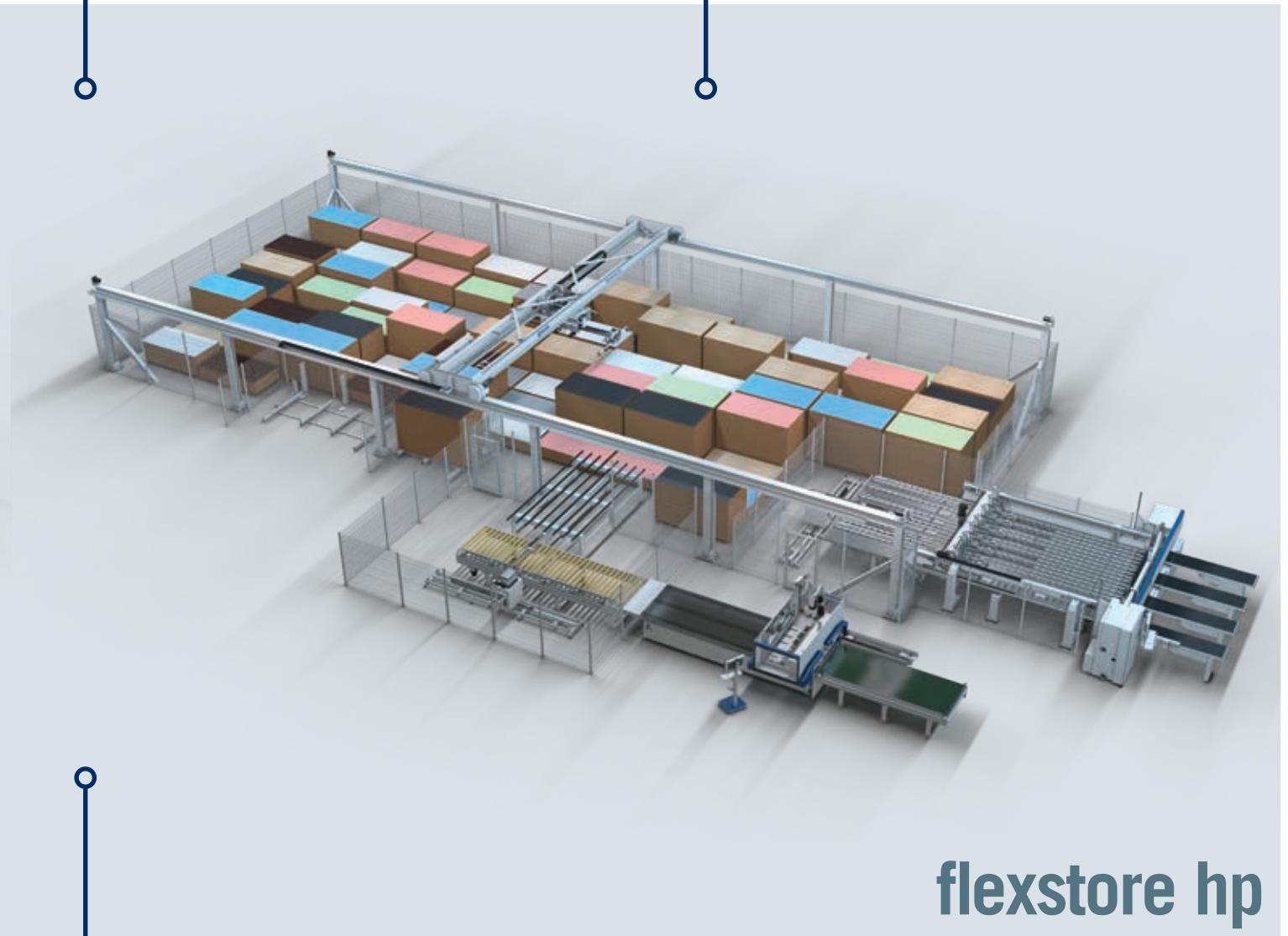

**flexstore hp**

We have improved the ergonomics and safety levels and reduced the possibility of accidental damages to the products compared to traditional manual handling.

\* shifts of 8 hours, average stroke (Y) 24 m.



# FRAME



The steel supporting frame of the storage has been designed to guarantee high levels of performance and long-term reliability.

# PICKUP TABLE

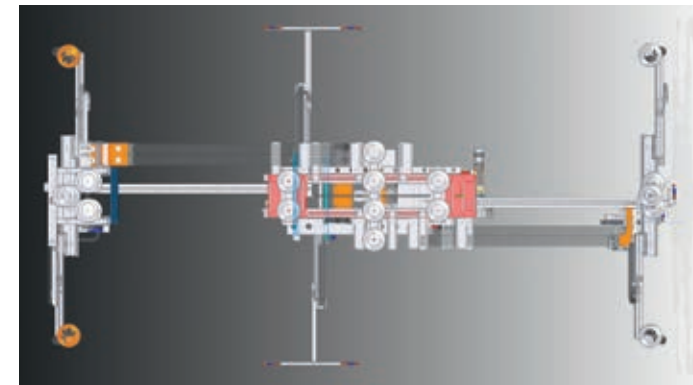

The suction cups support table adapts automatically to the dimensions of the boards.

It is fitted with a device for the frontal release of the panels and for handling unfinished and thin panels.

The panels position check and correction device allows for the maximum yield of useful area, reducing the minimum distance between the storage stations up to 100 mm.

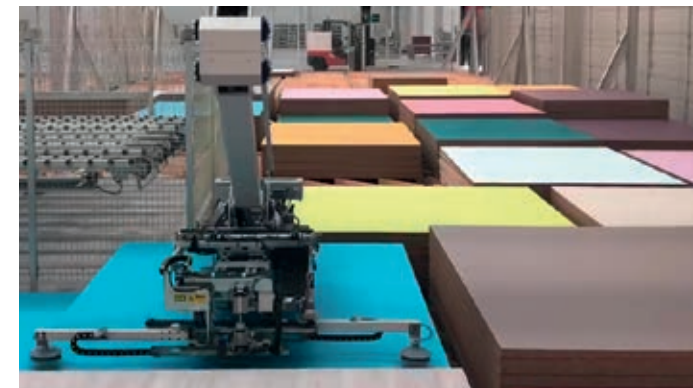

# LIFTING SYSTEM

The lifting system (axis Z) consists of a **pantograph** (single or double) that reduces the height of the storage. Thanks to the **rotation of up to 270°** users can lay out the panels in the storage and on the machines as necessary.



# COMPLETE TRACEABILITY

In the automatic integrated processes, the panel can be tracked thanks to the **automatic labelling**, performed in line with the cutting diagram, before it is machined by the machine.

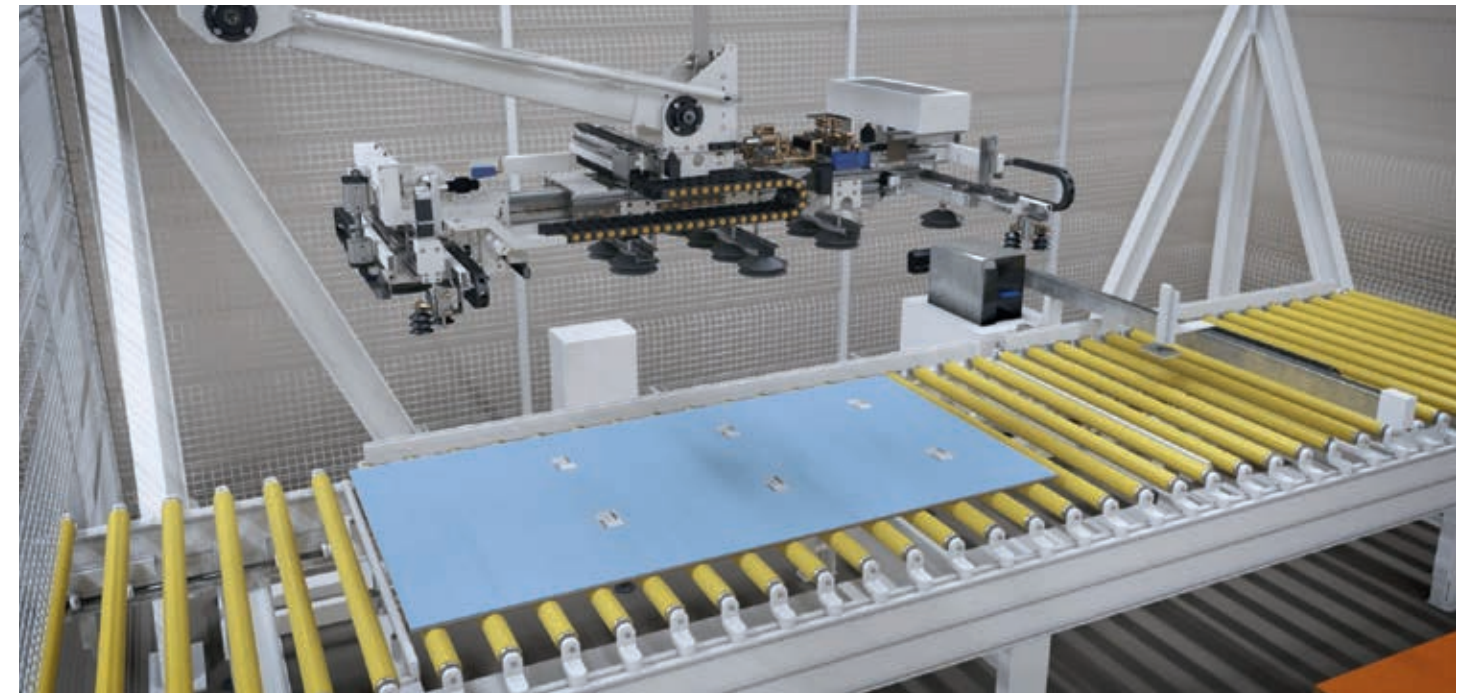



# M Maestro Digital Systems

INTELLIGENT SOFTWARE AND DIGITAL SERVICES TO IMPROVE THE PRODUCTIVITY OF THE WOOD-WORKING AND FURNITURE INDUSTRY

SCM provides support to wood-working companies throughout their process, combining machines with software solutions and digital services with a constant eye on improving the performance levels to optimise the company's production capacity.

The SCM software solutions have been developed to allow an integration with the software already being used by companies, to optimise the use of the machine and the entire process.

## Maestro active store

Maestro active store is the supervision software developed by SCM to manage the automatic flexstore storages.

The software is able to monitor in real time the process operations, optimising the identification, handling and labelling of the formats being machined and the management of the production offcuts.

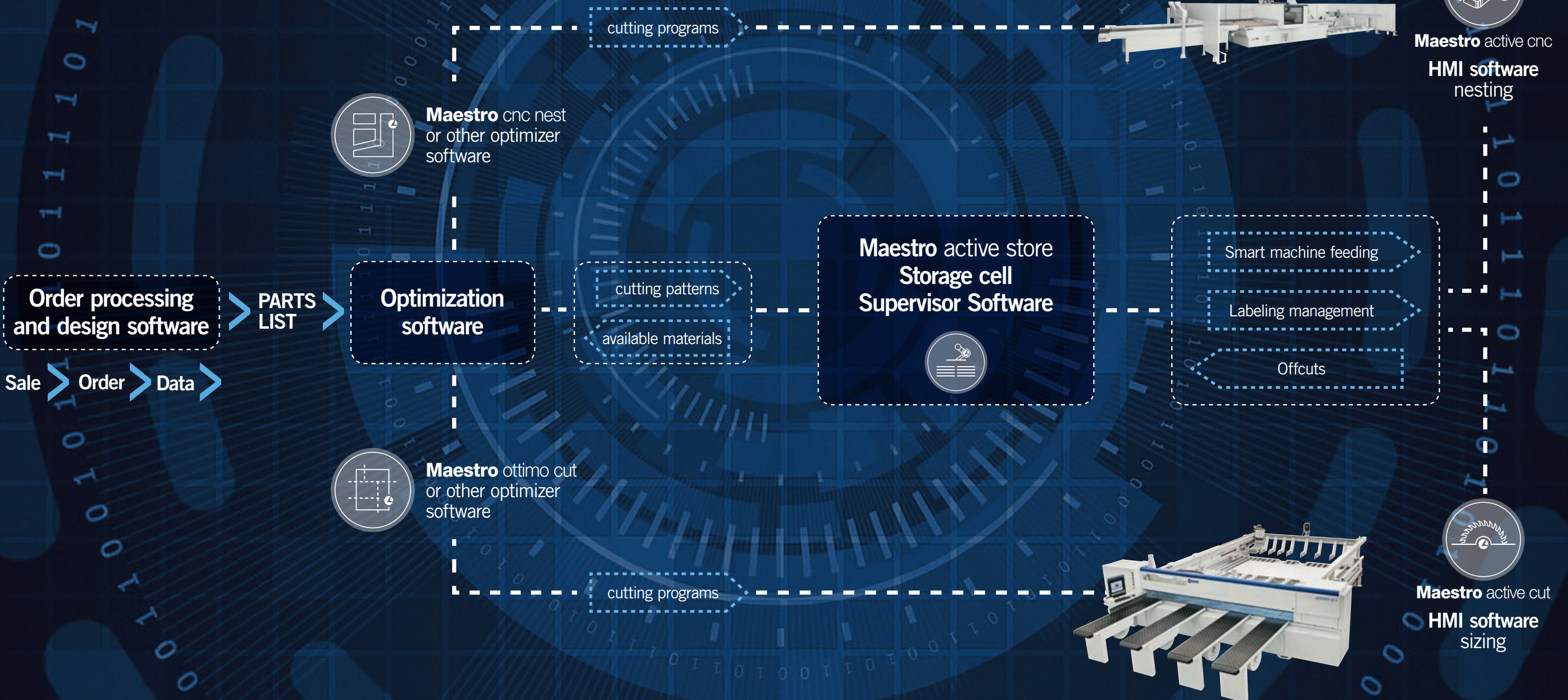





# Maestro active store

Maestro active store can be integrated with the company's IT system:

- to receive cutting diagrams from SCM or external optimisers
- to provide production reports for the MES and/or the company software.



## FUNCTIONS



### Real time process control

Real time management and monitoring of the production cell, through a signal and data exchange with the machines.

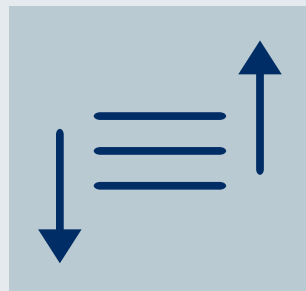

### Dynamic sorting of the storage

Optimal planning of the stock in the storage area, based on their previous use in order to minimise the picking times.



### Multi-client interface

Multi remote access from various stations at the same time with set access levels based on user profiles.

## FUNCTIONS

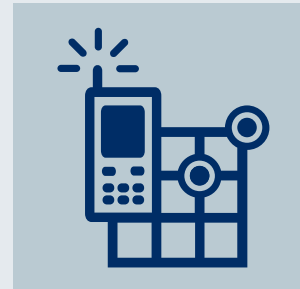

### Storage mapping

Real time display of the position of the material.



### Offcut Management

Automatic warning of the availability of offcuts and their picking positions if located in an external storage.



### Production reports

Reports of the production KPI always available. For example users can display and share all the information relative to the single operator, shift or program with the company management software system.



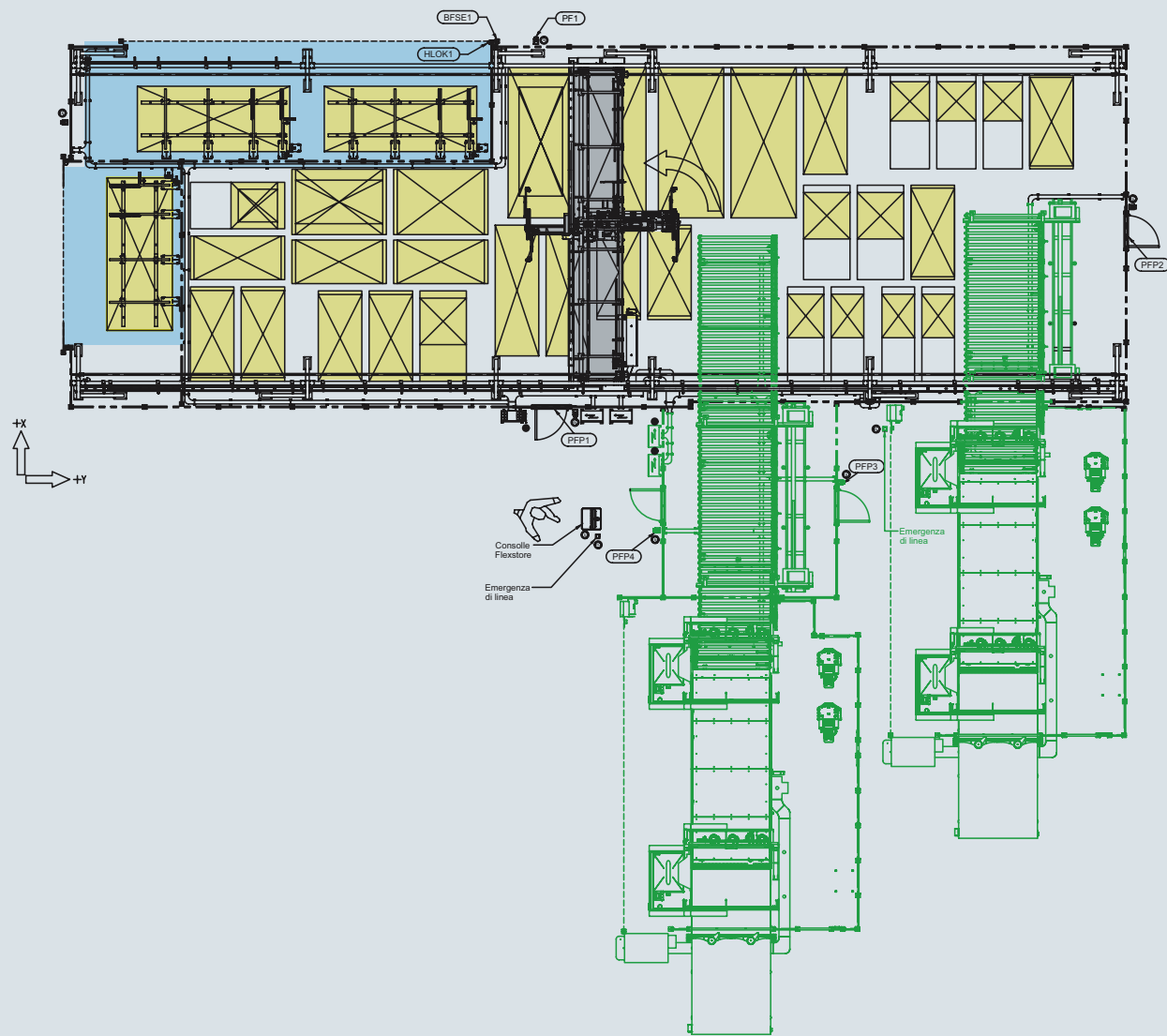

Highly flexible cutting system for extremely varied components

consisting of:

- Automatic boards storage.
- Nesting operating machines.
- Automatic labelling stations.

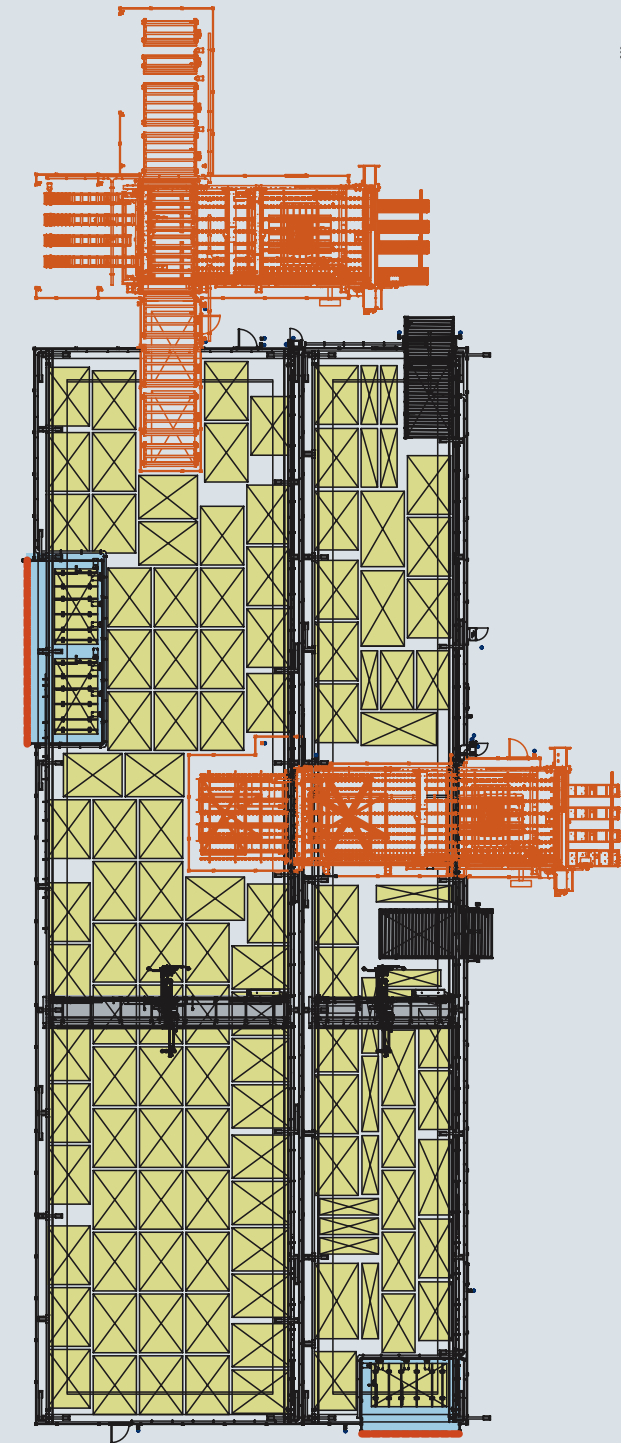

Cutting system with built-in offcuts recovery, consisting of:

- Automatic boards and offcuts storages.
- Sizing operating machines fitted with automatic labelling system.



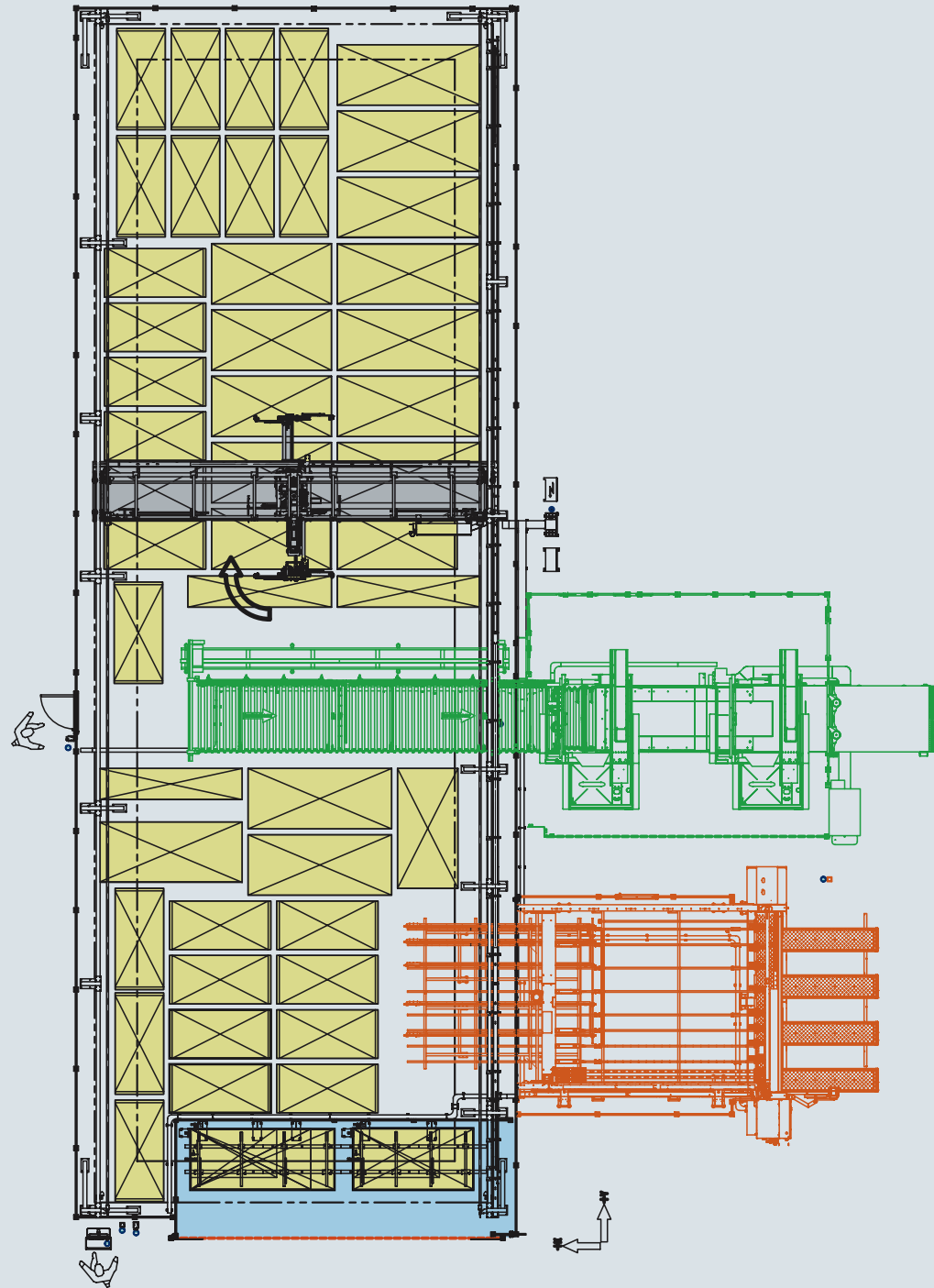

Additional cutting system for cutting a single sheet and packs, consisting of:

- Automatic boards storage.
- Sizing operating machine.
- Nesting operating machine.
- Automatic labelling stations.

## flexstore el

Storage width	m	7 - 9 - 12
Storage length	m	12 ÷ 60
Axes speed (X, Y, Z)	m/min	80 - 80 - 35
Panel width	mm	800 ÷ 2200 400 ÷ 2200 (opt.)
Panel length	mm	1800 ÷ 3200 2200 ÷ 4250 (opt.)
Panel thickness	mm	Coated: 10 ÷ 40 (opt. 3 ÷ 40) Raw MDF: 16 ÷ 40 (opt. 3 ÷ 40) Raw chipboard: 16 ÷ 40 (opt. 6 ÷ 40)
Stack maximum height	mm	2000
Maximum panel weight	kg	200

## flexstore hp

Storage width	m	9 - 12 - 16
Storage length	m	12 ÷ 60
Axes speed (X, Y, Z)	m/min	100 - 150 - 45
Panel width	mm	800 ÷ 2200 400 ÷ 2200 (opt.)
Panel length	mm	1800 ÷ 3200 2200 ÷ 4250 (opt.) 2400 ÷ 5600 (opt.)
Panel thickness	mm	Coated: 10 ÷ 40 (opt. 3 ÷ 40) Raw MDF: 16 ÷ 40 (opt. 3 ÷ 40) Raw chipboard: 16 ÷ 40 (opt. 6 ÷ 40)
Stack maximum height	mm	2000 (opt. 2500)
Maximum panel weight	kg	250 (opt. 350)



# PROMPT AND EXPERT TECHNICAL SUPPORT THROUGH A NETWORK OF 1000 TECHNICIANS AND AN INVENTORY OF 36,000 SPARE PARTS.

HIGHLY SPECIALISED TECHNICIANS, EFFICIENT MANAGEMENT AND 6 SPARE PARTS BRANCHES AROUND THE WORLD GUARANTEE A CLOSE, SAFE AND EFFECTIVE TECHNICAL SUPPORT.

## SERVICE

SCM provides a service that goes beyond the purchase, to guarantee the long term performance of your technological production system and peace of mind for your business.

### A COMPLETE RANGE OF AFTER-SALES SERVICES

- installation and start-up of machines, cells, lines and systems
- tailored training programs
- telephone support to reduce times and costs when machines are not working
- preventive maintenance programs to guarantee long term performance
- complete renovation of machines and plants to renew the added value of the investments
- custom upgrading to update machines and plants and meet new production requirements

## SPARE PARTS

SCM Group can count on 140 spare parts professionals worldwide to meet any request with real time shipments.



### 36,000 SPARE PARTS

Our spare parts inventory, with a value of 12 million euros, covers every single machine



### SPARE PARTS GUARANTEED

We guarantee also hard to find parts, with 3,5 million euros invested in "critical" spare parts.



### IMMEDIATE AVAILABILITY

Over 90% of orders received are carried out the same day thanks to the huge inventory available.



### 6 BRANCHES AROUND THE WORLD

The spare parts service can count on worldwide support (Rimini, Singapore, Shenzhen, Moscow, Atlanta, São Bento do Sul)



### 500 SPECIALISTS AROUND THE WORLD

# THE STRONGEST WOOD TECHNOLOGIES ARE IN OUR DNA

## SCM. A HERITAGE OF SKILLS IN A UNIQUE BRAND

Over 65 years of success gives SCM the centre stage in woodworking technology. This heritage results from bringing together the best know-how in machining and systems for wood-based manufacturing. SCM is present all over the world, brought to you by the widest distribution network in the industry.

65 years history

3 main production sites in Italy

300.000 square metres of production space

20.000 machines manufactured per year

90% export

20 foreign branches

400 agents and dealers

500 support technicians

500 registered patents

In SCM's DNA also strength and solidity of a great Group. The SCM Group is a world leader, manufacturing industrial equipment and components for machining the widest range of materials.

## SCM GROUP, A HIGHLY SKILLED TEAM EXPERT IN INDUSTRIAL MACHINES AND COMPONENTS

### INDUSTRIAL MACHINERY

Stand-alone machines, integrated systems and services dedicated to processing a wide range of materials.



WOODWORKING TECHNOLOGIES



TECHNOLOGIES FOR PROCESSING COMPOSITE MATERIALS, ALUMINIUM, PLASTIC, GLASS, STONE, METAL

### INDUSTRIAL COMPONENTS

Technological components for the Group's machines and systems, for those of third-parties and the machinery industry.



SPINDLES AND TECHNOLOGICAL COMPONENTS



ELECTRIC PANELS



METALWORK



CAST IRON







**SCM GROUP SPA**

via Casale 450 - 47826 Villa Verucchio, Rimini - Italy  
tel. +39 0541 674111 - fax +39 0541 674274  
scm@scmgroup.com  
www.scmwood.com



00L0257112H