

Unimat-Series

The flexible moulder
for planing, sawing and profiling

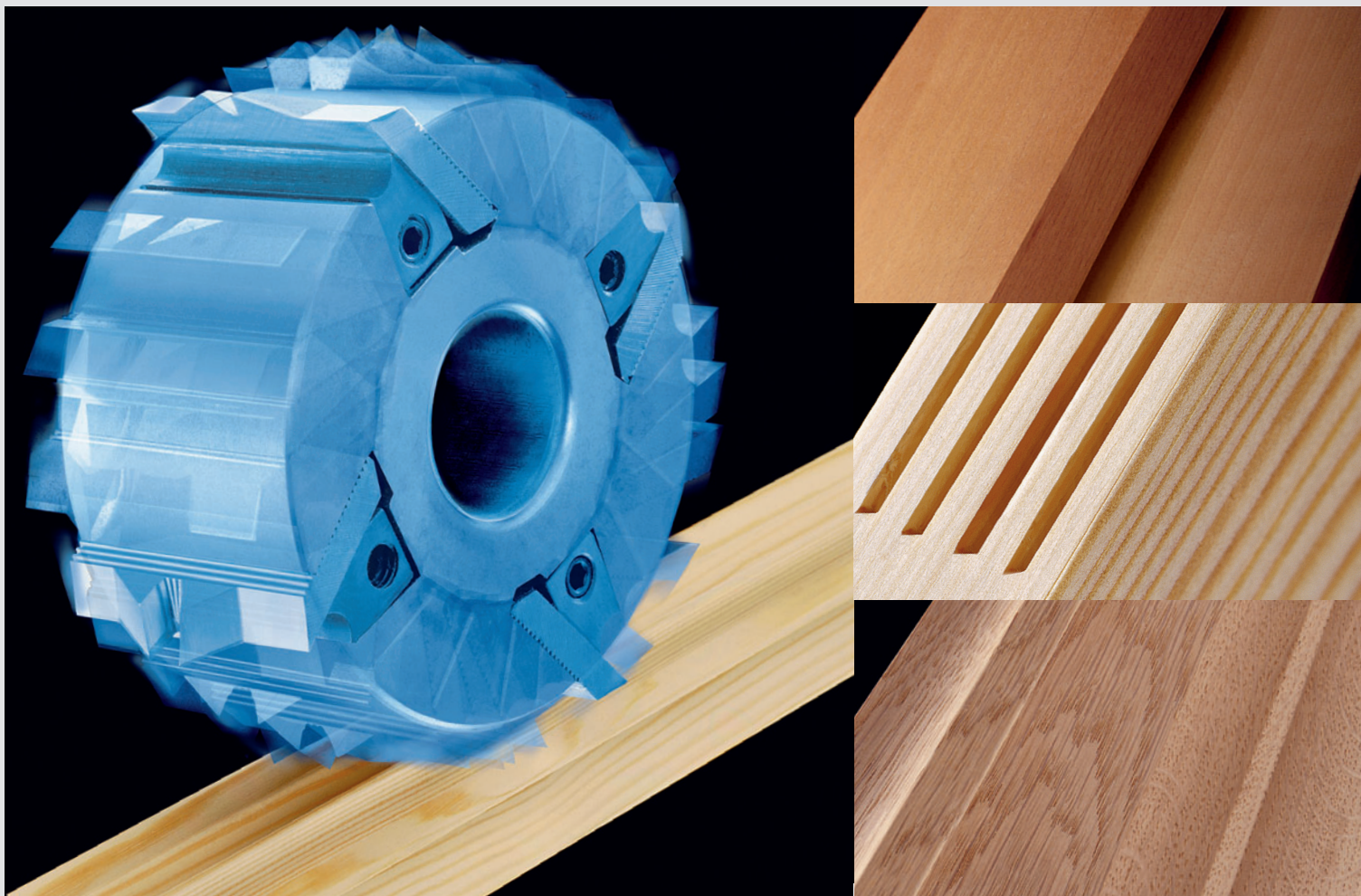

WEINIG presents: The universal moulding machine concept

Unimat means the quality that you need to tackle the pressures of the constantly changing business climate and demanding workload. No other moulder operates in as many plants worldwide as the WEINIG Unimat. As a result it is the most tried and tested moulder that has ever been built. Efficient for large and small batches and durable for multiple shift operation with an outstanding surface finish. Whatever you want to produce, from solid wood or wood substitute materials such as MDF or even plastic – products such as windows and doors or custom profiles – the quality must be first class in every case and production efficiency must be guaranteed.





The Unimat series fulfills all these demands, from the starter model Unimat 300 to the power-packed Unimat 23 EL. But special applications are also easily addressed. For example, the heavy-duty Unimat 23 SP sawing unit for thin veneers or the precise planer for edge gluing, the Unimat Super 4. Around the machine you build your individual production support: tooling, measuring and data systems, set-up aids, tool grinders, and feeders. All from one source. All from WEINIG. Productivity without limits, intelligently customized to your unique production process.



The Unimat –

strong, precise and flexible for all demands when planing, sawing and profiling:

- Excellent performance
- Superior surface quality
- Durable and precise
- Optimal solution for every demand
- Fast and simple set-up
- Easy to operate
- Maximum safety
- Easy integration into existing production with WEINIG system solutions
- Special solutions for unique applications



WEINIG machine technology: Our experience pays off for you

A high quality heavy cast iron base absorbs vibration and is the solid, stable platform for our high-precision spindles and smooth, robust feed system. WEINIG's high quality, precision spindle construction uses heavy duty bearings and a flat belt drive that contributes to quiet operation and incomparably smooth surfaces on all moulded or S-4-S products – even when under heavy load. Spindle speeds of up to 8,000 rpm!



WEINIG Unimat 300: Universal with strong standard:

We redefine the phrase “first moulder” with WEINIG moulding technology! With this model, you can produce extremely efficiently and profitably. The Unimat 300 is easy to operate and offers a full range of standard equipment. Extremely space-saving and compact, it will plane and mould 9 1/16” wide and 4 3/4” thick. Both the 4 and 5 spindle models handle almost any application.



WEINIG Unimat 500: With new set-up technology



The Unimat 500 is the essence of experience and includes our latest set-up technology. Precise, fast and repeatable resetting can easily be achieved via the WEINIG Memory System. Once produced and its measurements stored, a profile can be repeated at any time – with exacting precision and minimal setting time. With 8 models ranging from 5 to 8 spindles, the Unimat 500 can be used for practically all demands. Short distances between the spindles keep this moulder compact and easy to find a place for in your shop. With optional PowerCom System and motorized spindle positioning, it can be made into a simple, quick-change machine.

WEINIG Unimat 23 EL: The strongest of the Unimat series

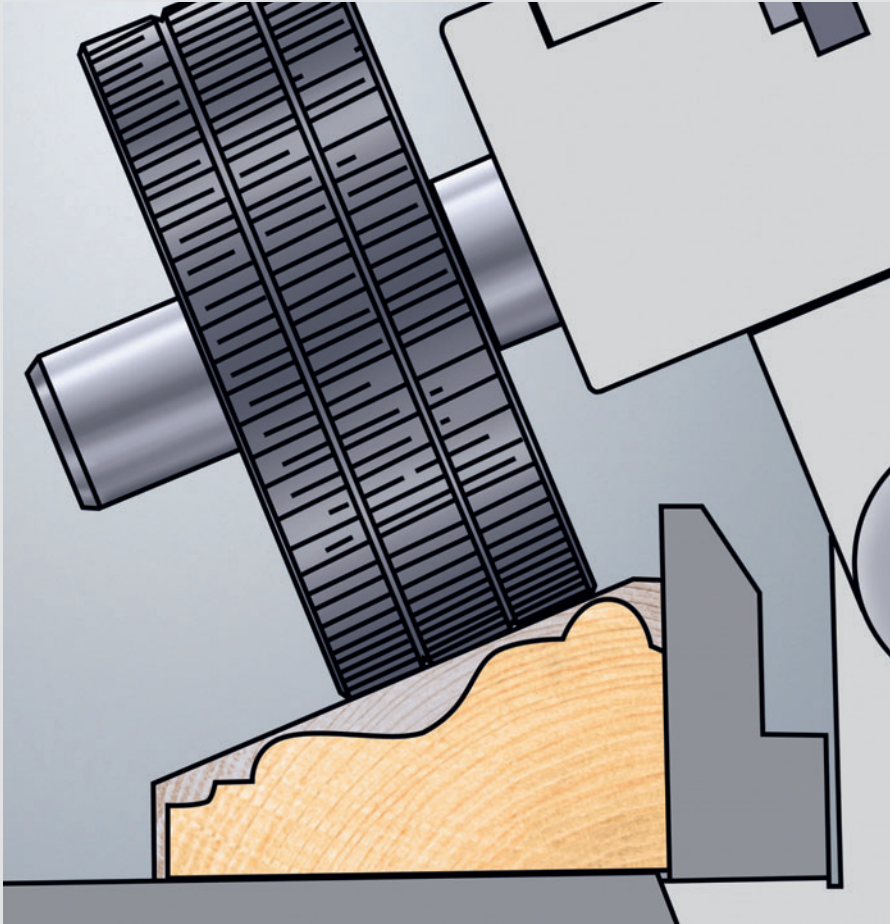

Large and small batches – the ideal task for the strongest machine of the world's most successful moulder series. A modular system permits unlimited variations and allows for all conceivable demands.

The Unimat 23 EL supports the highest productivity equipment, such as 3 1/8" travel on the vertical spindles for time-saving set-up of several stacked tools, speeds up to 8,000 rpm (additional capacity of 30%!), spindle motors up to 50 HP for sawing and deep cuts. Straight jointers to extend working time, together with the best surface and fastest feed speed. Multiple feed wheels above and driven table rollers assure smooth, reliable feeding of your product.

The ideal machine for use in production lines. Simplify and decrease setting time by including the optional Memory System, PowerCom System and motorized spindle positioning.



WEINIG Unimat 23 SP: Specialist for precise sawing of thin veneers



High speed production of high quality thin veneer used for engineered flooring, face veneers for doors and much more. Thin kerf saw blades, combined with blade coolant spray, prolong the service life and provide an additional yield of 20% and more. The Unimat manages to do this at feed speeds which are several times higher than other machines on the market. Optional scoring saws are available to reduce grain chip-out and increase feed speeds, as well as a special powered feed unit for safe and positive outfeed of the last workpiece.

WEINIG Unimat Super 4: Perfection for gluing solid-wood boards

WEINIG's expertise has made four-sided processing with only 3 spindles possible... and at feeds of 78 ft/min and more – producing great edge-gluing surfaces! A combination tool on the top spindle guarantees quality gluable surfaces and exact 90° angles. The groove guide technique also permits running short parts and unsquared ends. All the above are requirements for the production of edge-glued solid-wood boards and panels.

The compact, space-saving Unimat Super 4 is ideal for preparing stock for the glue press.

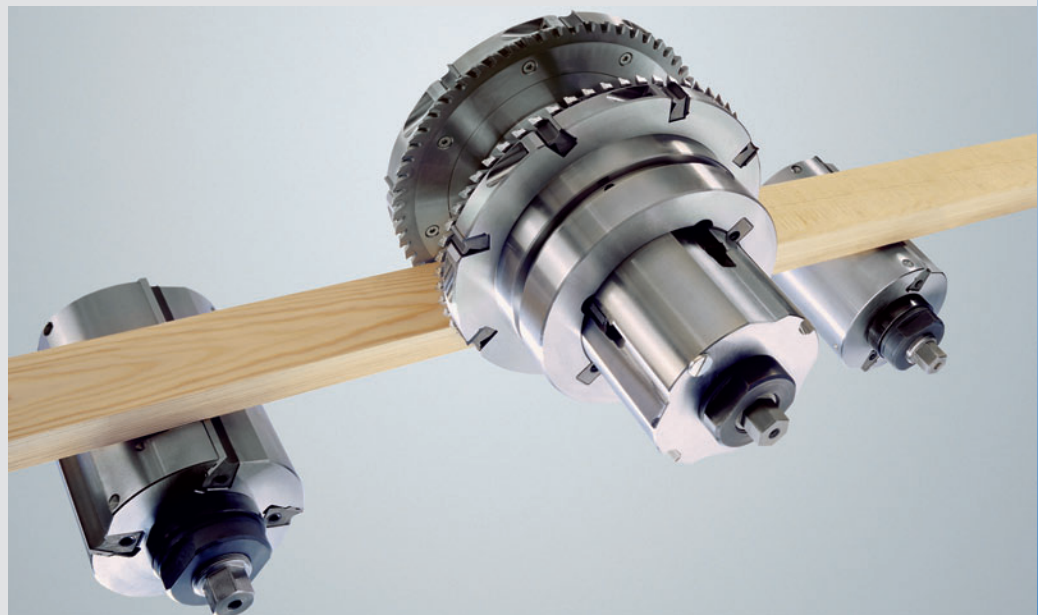

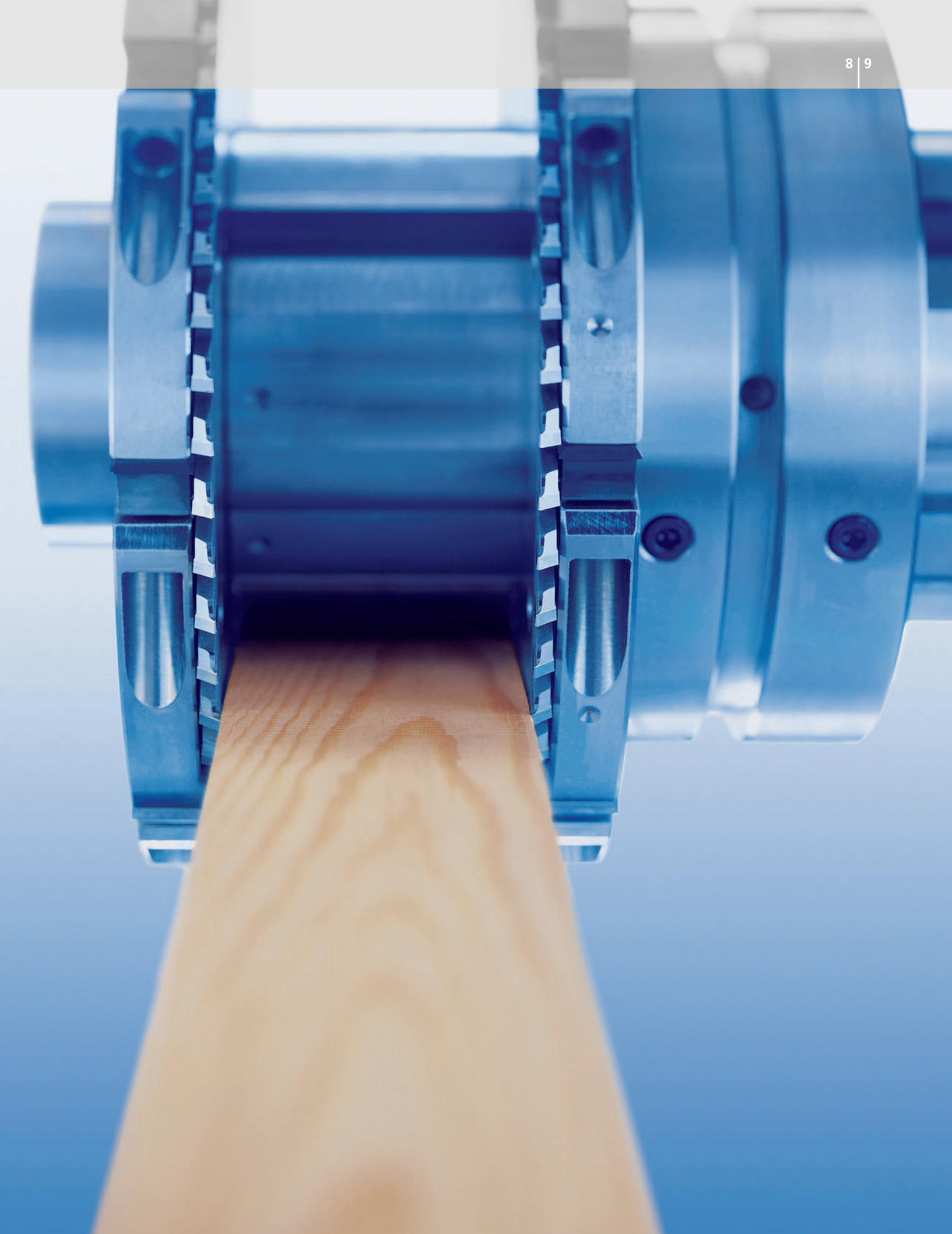

The intelligent Unimat controls: It is so easy to master High-Tech

The times when only specialists could operate a moulder are gone. WEINIG controls are simple and at the same time extremely powerful. Simple graphics guide an operator through a set-up. A high-capacity memory allows storage for thousands of profile dimensions and tooling information.

Memory System

With the Memory System you can program, store, retrieve and repeat your profile data all with the push of a button. No repetitive data input. The setting values are displayed electronically with an exactness of $\pm 0.002''$. And the machine is ready to go!



PowerCom System

The PowerCom System offers the advantages of the Memory System with the addition of almost unlimited profile and tooling data. With the simple-to-use touch screen you are guided through every change-over with ease. You decide what profile and tooling data to save for future use and what your production order sequence will be for that day.



Add-on modules for the Unimat: Clever solutions to your production problems

Modern production means you must adjust to the ever-changing demands of your customers. WEINIG offers you several ways to adapt your Unimat even more closely to the demands of the market.

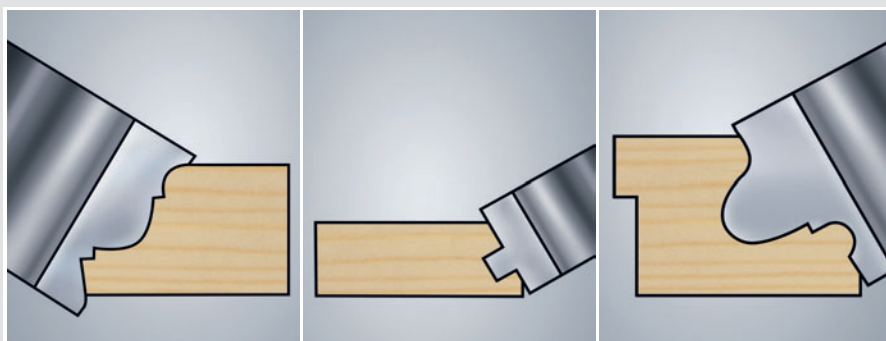

The Universal spindle is what you need for certain complicated production tasks. Usable in a 360-degree rotation, it means an additional spindle on every side and manages even the most complicated kerfing, grooving and limited profiling in a single run.

The 2nd right vertical spindle is positively tiltable from 0 – 45° and is used when profiles require angled grooves and have to be milled from the right side. As a fully operational profiling spindle with up to 8,000 rpm it provides a surface finish equal to any other spindle on your moulder.

The mobile spindle makes your work considerably easier if you process random width raw material. A true multi-tasker, it automatically measures and adjusts itself to the relevant width of the work-piece and processes it.

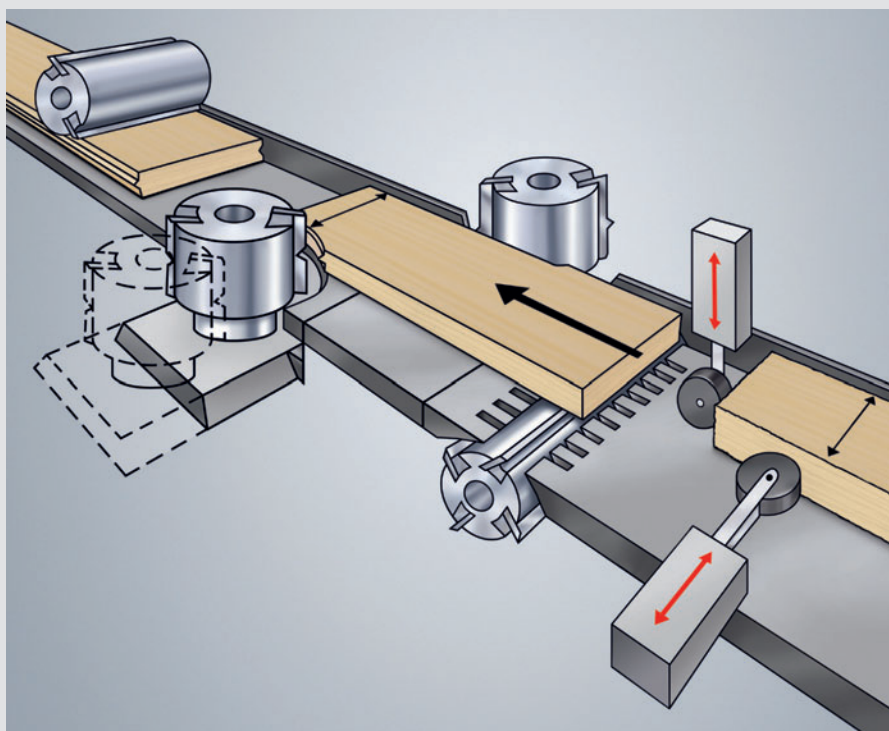

Unimat with chamfer unit: Chamfering on 4 sides without resetting

It does not matter what widths or thicknesses you manufacture – together with the top and left spindles the WEINIG chamfering unit moves into the necessary position. Tool changes are not necessary, even with different wood dimensions!



Unimat 23 EL with straight jointer: Top quality with feed speeds up to 120 ft/min

Superior surface finish at high speeds requires all knives to have identical cutting circle diameter. For this, the WEINIG Straight Joint System is unequalled in the industry. The hydro clamping cutter head technology fits ideally with the jointing process.



Unimat with WEINIG feed system: Smooth, reliable feed through the moulder

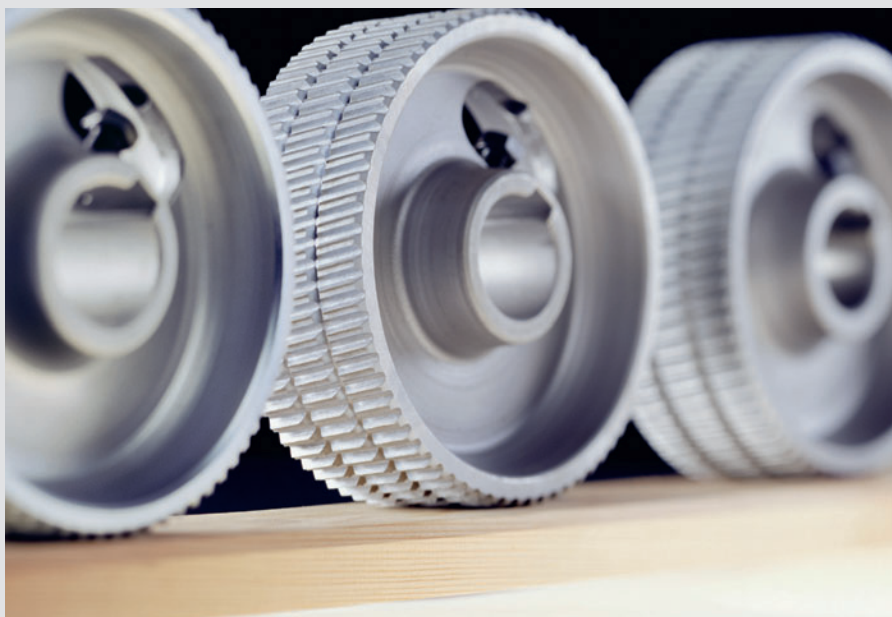

Whether you process wood, MDF or plastic – the WEINIG feed system ensures that you get a superior end product. With a special tooth design, the chromed feed wheels above the table and the adjustable, driven rollers in the table provide constant, smooth feeding. The chainless cardan drive is strong, durable and practically maintenance-free.

Unimat 23 EL with automatic straightening system: Faster, safer, better for maximum wood yield

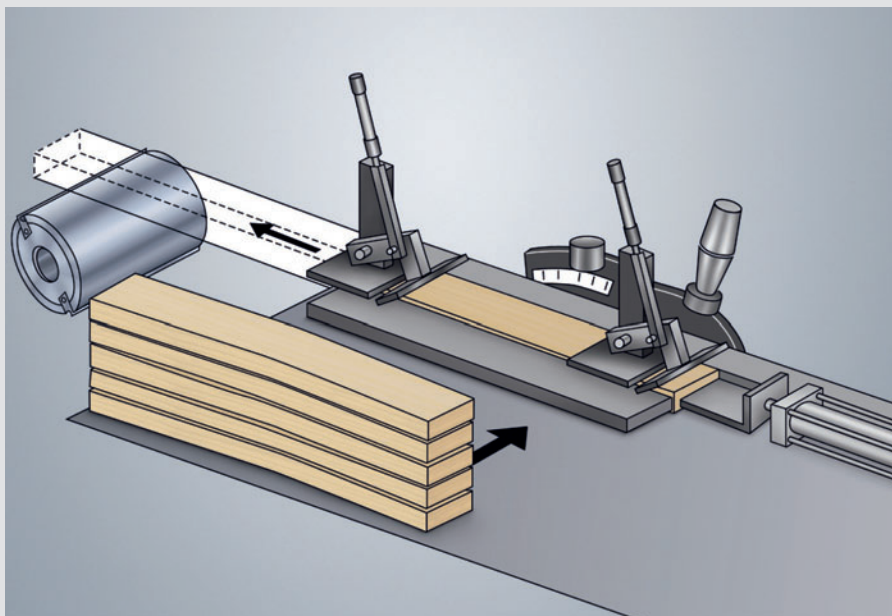

Forget complicated measuring, setting and manual feeding of every single workpiece during a straightening operation. With the automatic thickness measuring and surfacing system, just put the desired workpieces into the feed magazine and set the required thickness. Done. The precision of the system saves wood and a specialist is not needed. Pneumatic cylinders push the workpieces up to the fence and into the feed rollers.

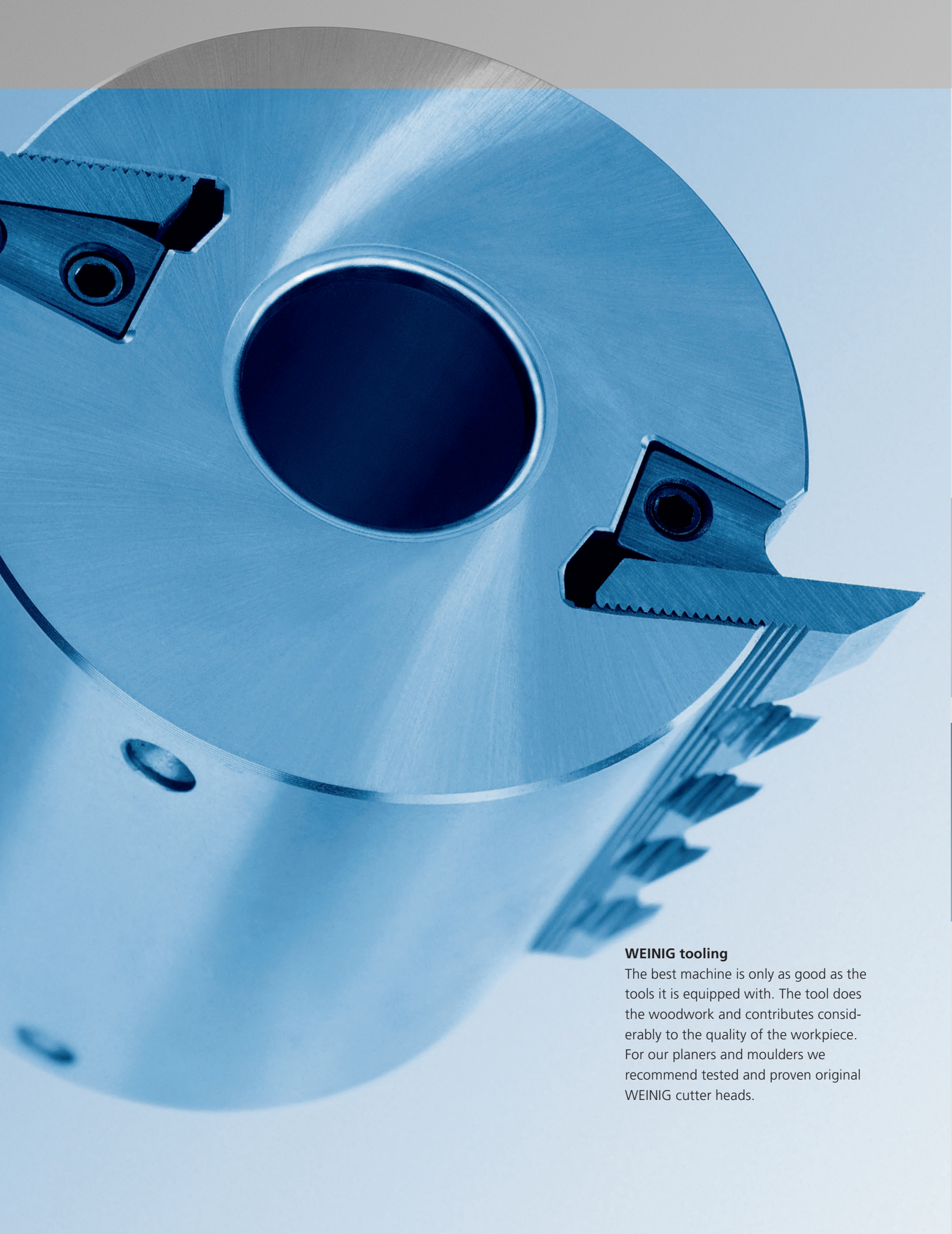

WEINIG tooling

The best machine is only as good as the tools it is equipped with. The tool does the woodwork and contributes considerably to the quality of the workpiece. For our planers and moulders we recommend tested and proven original WEINIG cutter heads.

WEINIG has the total package: The right accessories for the Unimat

The new WEINIG machine concept is more than just the Unimat series. Around the machine we offer peripherals that fit like a modular system. Choose one or all now, or add one later, resulting in production-enhancing solutions to best prepare for the challenges ahead.



WEINIG OptiControl PowerCom

PowerCom links all your PowerCom- and CAS LogoCom-equipped WEINIG moulders and the grinding room. All data is transferred from the optional PC on the OptiControl measuring stand to

the moulder's PC. The setting data is automatically displayed at the relevant spindle read-out and pressure element, further reducing the machine's setting times.

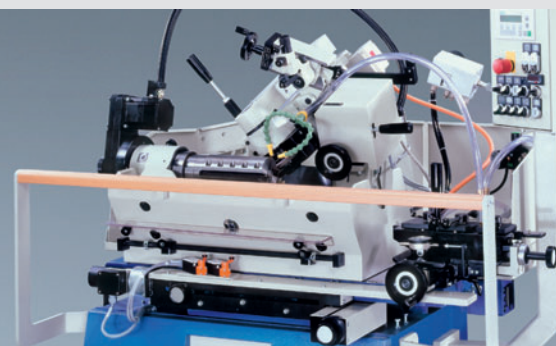

Grinding, sharpening, profiling with the Rondamat

Whoever can deliver quickly has the advantage. Produce profile and straight tools yourself within a short time. From manual to fully automatic we have the right grinder for every demand.



Automatic template production

Flexibility is your advantage! Produce your own profiling tools within the shortest time. The template router will make the necessary profile template, including the axial constant reference system. Without any manual drawing, with top precision, repeatable at any time. Ideal for multiple mouldings: draw them once, and then just reproduce.



Automation with WEINIG EM 11 hopper feed

– a must for production of short or long pieces. Get the most out of your machine. Additional advantages: the hopper feed is mounted to the straightening table, and can be quickly removed for manual feeding. Optimal for feeding parts with different lengths.

Unimat overview: Standards and options

This matrix shows the essential differences between the individual models. Your WEINIG expert will gladly provide you with even more detailed information taking your individual needs into consideration.

	Unimat 300	
Working height	½" – 4 ¾"	
Working width	¼" – 9 ⅙"	
10 1/4" working width	—	
Number of spindles	4 – 5	
Spindle diameter (standard)	1 ½"	
6,000 rpm	●	
Spindle diameter (optional)	40 mm	
8,000 rpm	—	
4,000 – 8,000 rpm	—	
Straight Knife Jointing System	—	
Memory System	—	
PowerCom	—	
PowerCom plus	—	
Spindle resetting with electronic display	—	
Motorized spindle positioning for setting width and thickness	○	
Motorized spindle positioning for all spindles	—	
Mechanical feed speed (standard)	20 or 40 ft/min	
Frequency-controlled feed speed (standard)	—	
Frequency-controlled feed speed (optional)	20 – 40 ft/min	
Chromed machine table	—	
Max. motor capacity 1 st spindle below	7.5 – 10 HP	
Max. motor capacity 1 st and 2 nd vertical spindle (joint motor)	10 – 15 HP	
Max. motor capacity 1 st and 2 nd vertical spindle (individual motors)	—	
Max. motor capacity 3 rd and 4 th vertical spindle (individual motors)	—	
Max. motor capacity horizontal spindle above	7.5 – 15 HP	
Max. motor capacity horizontal 2 nd spindle below	5.5 – 15 HP	
Length surfacing table	6 ½ feet	
Short feed tables	—	
Tool cutting circle 1 st spindle below	5" – 5 ⅙"	
Tool cutting circle right spindle	5" – 7 ⅛"	
Tool cutting circle left spindle	5" – 7 ⅛"	
Tool cutting circle upper spindle	5" – 7 ⅛"	
Tool cutting circle 2 nd spindle below	5" – 7 ⅛"	
Tool cutting circle universal spindle	—	
Adjusting range vertical spindle (axial)	1 ⅜"	
Adjusting range horizontal spindle, except 1 st spindle below (axial)	1 ⅜"	
Diameter feed rollers	5 ½"	
Groove guide rail	—	
Driven roller in the machine table	—	
Driven roller in the outfeed table	○	
Reference engraver	●	

Subject to technical modifications. Statements and pictures in this brochure may also include optional extras which are not included in the standard serial equipment. Some of the photos s

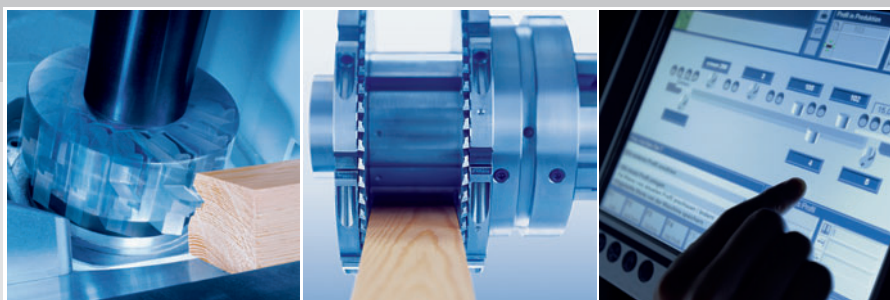

Unimat 500	Unimat 23 EL	Unimat 23 SP	Unimat Super 4
1/2" – 9 1/16"	3/4" – 9 1/16"	3/4" – 9 1/16"	1" – 6"
5/16" – 4 3/4"	5/16" – 4 3/4"	5/16" – 3 1/8"	5/8" – 2"
○	—	—	—
5 – 8	5 – 11	2 – 4	3
1 1/2"	1 13/16"	2 1/8"	1 13/16"
●	●	4,000 rpm	● (top spindle – 7,000 rpm)
40 mm	40 mm, 1 13/16", 50 mm, 2 1/8"	50 mm	—
—	○	—	—
—	○	○	○
—	○	—	—
●	○	—	—
○	○	—	—
—	○	—	—
●	●	○	—
○	○	—	—
○	○	—	—
—	—	20 to 120 ft/min	20 – 80 ft/min
16 – 100 ft/min	20 – 120 ft/min	—	—
—	20 to 120 ft/min	—	—
○	●	●	—
5.5 – 15 HP	5.5 – 15 HP	—	15 HP
7.5 – 15 HP	7.5 – 15 HP	—	—
5.5 – 15 HP	5.5 – 20 HP	20 – 50 HP	—
—	5.5 – 20 HP	—	—
5.5 – 15 HP	5.5 – 50 HP	—	30 HP
5.5 – 15 HP	5.5 – 50 HP	—	7.5 HP
6 1/2 feet	6 1/2 feet	—	6 1/2 feet
○	○	●	○
5" – 5 11/16"	5" – 7 1/8"	—	5"
4 3/8" – 7 7/8"	4 3/8" – 9 7/8"	7 1/8" – 13 3/4"	—
4 3/8" – 7 7/8"	4 3/8" – 7 7/8"	7 1/8" – 13 3/4"	—
4 3/8" – 7 7/8"	4 3/8" – 7 7/8"	—	9 7/8"
4 3/8" – 7 7/8"	4 3/8" – 9 7/8"	—	5"
4 3/8" – 7 7/8"	4 3/8" – 7 7/8"	—	—
2 1/8"	3 1/8"	3 1/8"	—
1 3/8"	1 3/4"	—	—
5 1/2"	5 1/2"	5 1/2"	5 1/2"
○	○	—	●
○	○	●	—
●	●	●	●
●	●	—	—

show the machine with the protective covers removed.

● Standard

○ Option

You can expect a lot from us: WEINIG GROUP – Your partner for the future

You can concentrate on your business, let us do everything else! The WEINIG GROUP is not only the leading manufacturer for the solid wood processing industry, we lead this industry in technology and ideas! WEINIG offers comprehensive services and system solutions – all the way to complete turnkey production plants – making the WEINIG GROUP the all-around ideal partner where the focus is always on flexible, profitable production.



The WEINIG ExpoCenter

In our ExpoCenter we can demonstrate to you how our top technology can benefit your operation. Here you can get a close-up view of all our machines.



Training

We want to see you get the maximum benefit from your investment as fast as possible. World-class WEINIG training takes care of that. Effective operator training classes taught by experienced WEINIG experts make sure that the machine will be fully productive within the shortest time frame.

Kaizen

WEINIG's own manufacturing process is successfully organized according to the Kaizen method. In a continuous improvement process, quality and efficiency are increased step by step. You can benefit from this at your plant: Via seminars, we will gladly pass on to you our many years of experience.

Service

With sales and service companies located on all continents and a large, mobile team of service technicians, we guarantee a worldwide service that is unique in the industry. Fast spare parts delivery everywhere and employees who speak your language are part of our reputation for the finest customer support anywhere.

**WEINIG**

World market leader
for automatic moulders

WACO

The No. 1 for high-speed
planers and moulders

GRECON

High-capacity finger
jointing lines

DIMTER

The specialist for
optimizing cross-cut
saws and laminating
presses

RAIMANN

Top technology for
length cutting

CONCEPT

The experts when it
comes to turnkey projects

The WEINIG GROUP: We make all the components of solid wood processing fit together seamlessly

Including full turnkey production plants

To build innovative machines is one thing, to offer complete system solutions is quite another. More and more often, however, our customers want an entire factory, including many different types of machines, from many different manufacturers, but want ONE responsible partner. Then, we involve our WEINIG CONCEPT team. They are top-notch specialists from every segment of

the woodworking processes. They handle everything from the initial planning to the turnkey production plant. Worldwide. With complete responsibility. For you.

A strong team

Each member of the WEINIG GROUP is a leader in its own field of wood processing. This creates market synergy, and you, our valued customer, are the beneficiary of this partnership.



Unimat-Series



Michael Weinig, Inc.
124 Crosslake Park Drive
P.O. Box 3158
Mooresville, NC 28117, USA
Phone (704) 799-0100
Fax (704) 799-7400
E-mail: weinig@weinigusa.com
Internet: www.weinigusa.com