

Akron 1300

automatic single-sided edgebanding machines

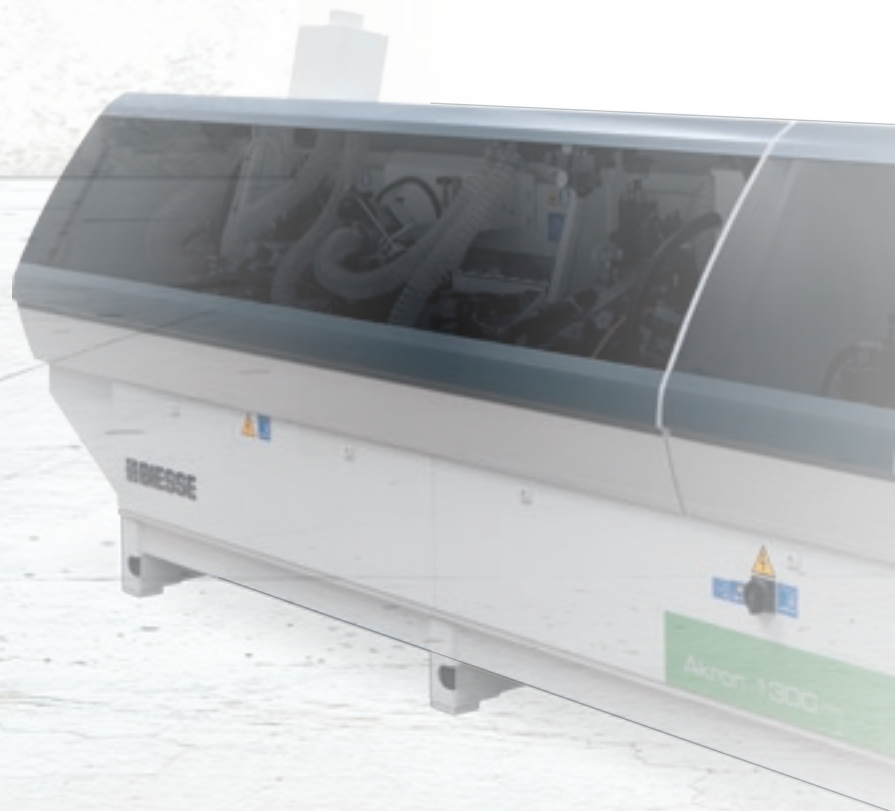

When competitiveness
means excellent
machining quality



Made **In** Biesse

The market demands

a change in manufacturing processes that enables companies to accept the **largest possible number of orders**. This is coupled with the need to maintain high quality standards whilst offering product customisation with quick and defined delivery times, as well as responding to the needs of highly creative designers.

Biesse meets these requirements with **technological solutions** that highlight and support technical expertise as well as process and material knowledge. **Akron 1300** is a range of automatic single-sided edgebanding machines purposely created for craftsmen and companies looking for user-friendly, customised production, flexible solutions in a limited space.

- 
- A photograph of the Akron 1300 edgebanding machine, showing its internal rollers and a workpiece being processed. The machine is white and industrial in design. Thin black lines are drawn over the image, pointing from the text to various parts of the machine.
- ▶ **Built according to the specific production requirements.**
 - ▶ **High finish quality.**
 - ▶ **Maximum working precision.**
 - ▶ **Technology at the service of the user.**

Modest investment,
high range technology

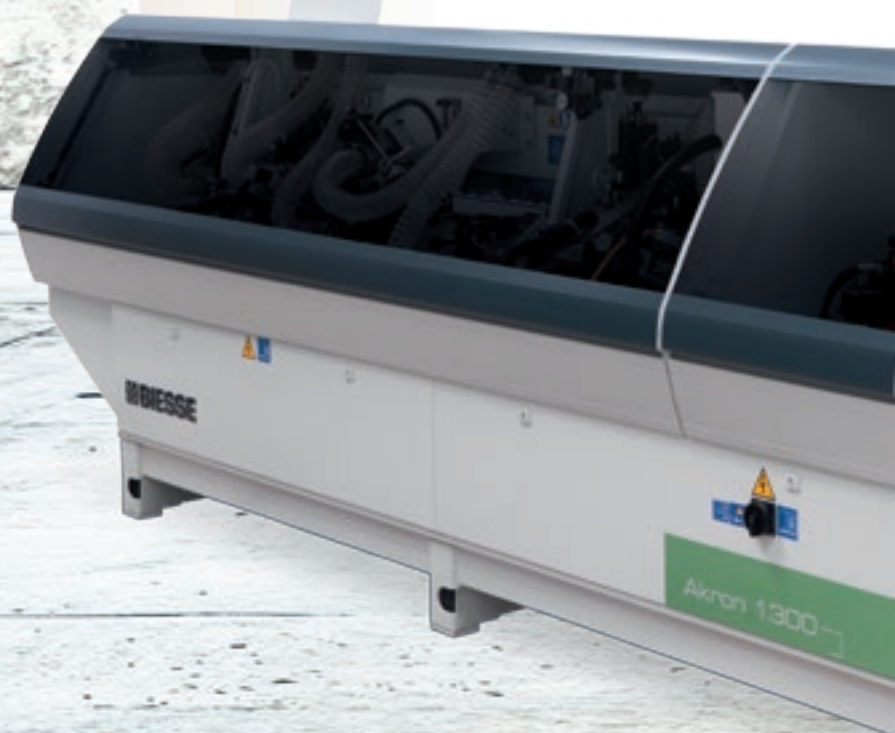

Akron 1300

automatic single-sided edgebanding machines



High finish quality

Perfect finish, due to the 2-motor Pre-milling unit with automatic intervention.



As standard, Akron uses only the electrospindles of the exclusive Rotax range on all the machines. These are electrospindles of the highest quality, designed and made by HSD (a leader in this sector); they guarantee optimum power, compact dimensions, and extremely high finishing standards.



The **Pre-milling Autaset** device for the automatic centring of the tool on the panel improves quality whilst reducing set-up times.

Ground-breaking technology, for top performance

Our specific Research & Development team creates pioneering solutions to meet the market requirements and offer cutting edge technology that's reliable and guarantees first class results.



Gluing unit for the automatic application of edging in rolls or strips, from 0.4 to 5 mm.



Invisible Edgebanding



Air Force System, available on Biesse edgebanding machines, is based on the physical principle of convection. By using a compressed hot air system, the edge bonds perfectly with the panel guaranteeing resistance to water and heat and an excellent long lasting quality finish.

AIRFORCESYSTEM

No joints and no glue line, in perfect harmony with the panel. A perfect combination of Biesse quality and Italian genius.



Maximum working precision

Unprecedented product quality and reduced machining times, thanks to technological solutions created for the specific day-to-day work.



Reliability and cutting accuracy, due to the End Trimmer that removes excess edge at the front and rear of the panel. The Flex system, which is standard on the end trim automatically adjusts the excess edge whether the corner rounding unit is or is not being used.

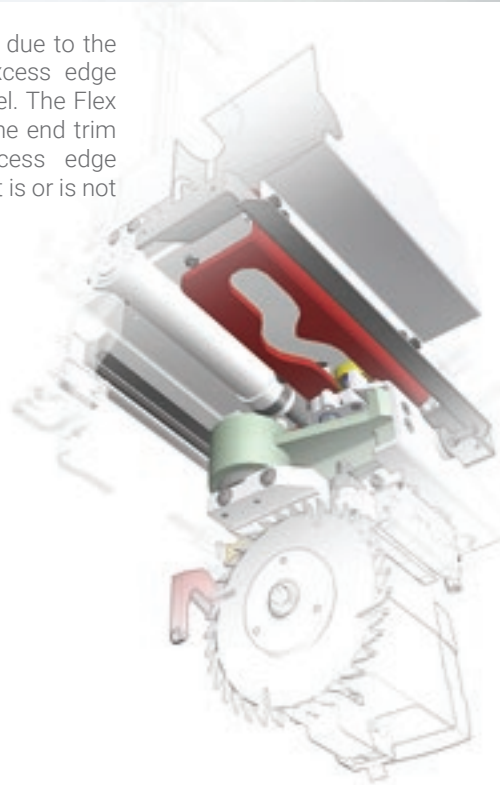

Optimal quality, accuracy and reliability with the new DESMO linear edge trimming unit, with "tracking" copying system.



The **Fine Trimmer** for the top and bottom edges. Available in a manual or automatic version, complete with 2 high-frequency motors and vertical/horizontal copiers with rotating disc.

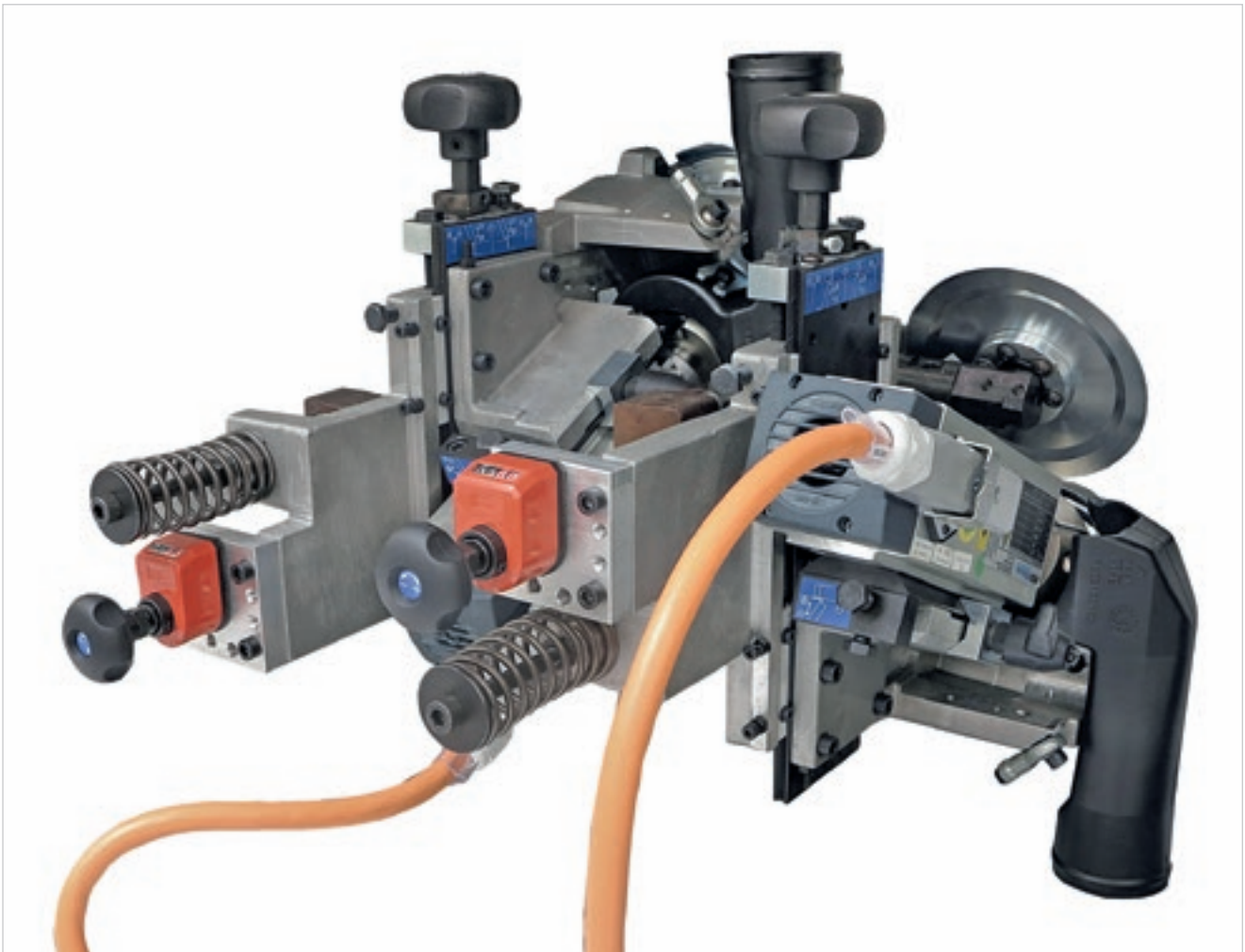

Stepper Motor

The working units can all be equipped with automatic axis for the machining changeover. Fitted with motors with an axis positioning tolerance of 0.01 mm, they ensure optimum machining accuracy.

Flawless edges

The End Trimmer assembled on an Akron 1300 is the most competitive and high performance solution of its type. High range technology, ideal for delicate and High Gloss surfaces due to the copying and tracing system that doesn't involve any form of rubbing or scraping. It ensures an extremely reduced gap between panels (unique on the market), to increase productivity.

HIGH GLOSS EDGES

Highly technological solutions for perfect machining of the most delicate surfaces as well as maximised productivity. A perfect combination of Biesse quality and Italian genius.

 **BIESSE**

 **BIESSE**

High quality products

The multipurpose **Corner rounding tool** with two motors is used to apply radiusing not only on the front and rear edges but also on the upper and lower parts of the panel.

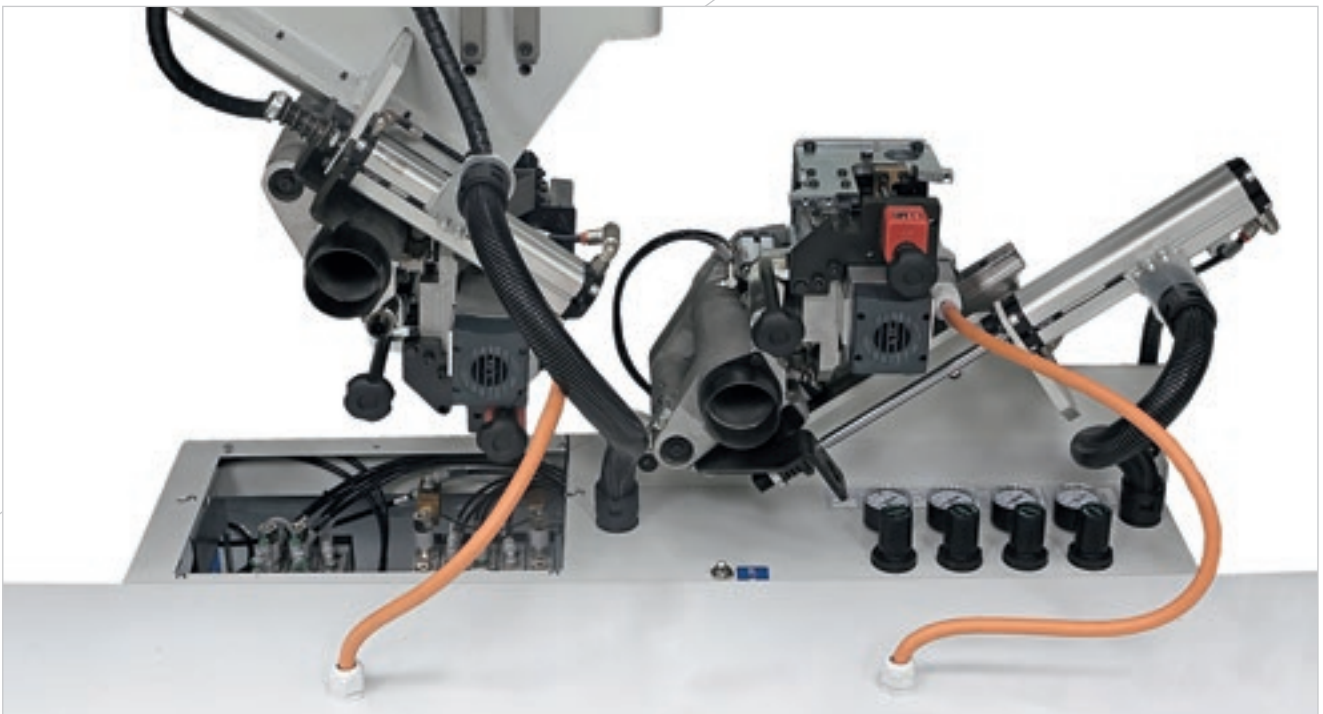

The **Rough Trimmer** reduces the excess edge on the upper part of the panel.



The **Grooving Unit** creates grooves and performs milling operations on the underside of the panel.



The **Edge scraper** eliminates imperfections resulting from previous machining operations on the top and bottom of the edge.

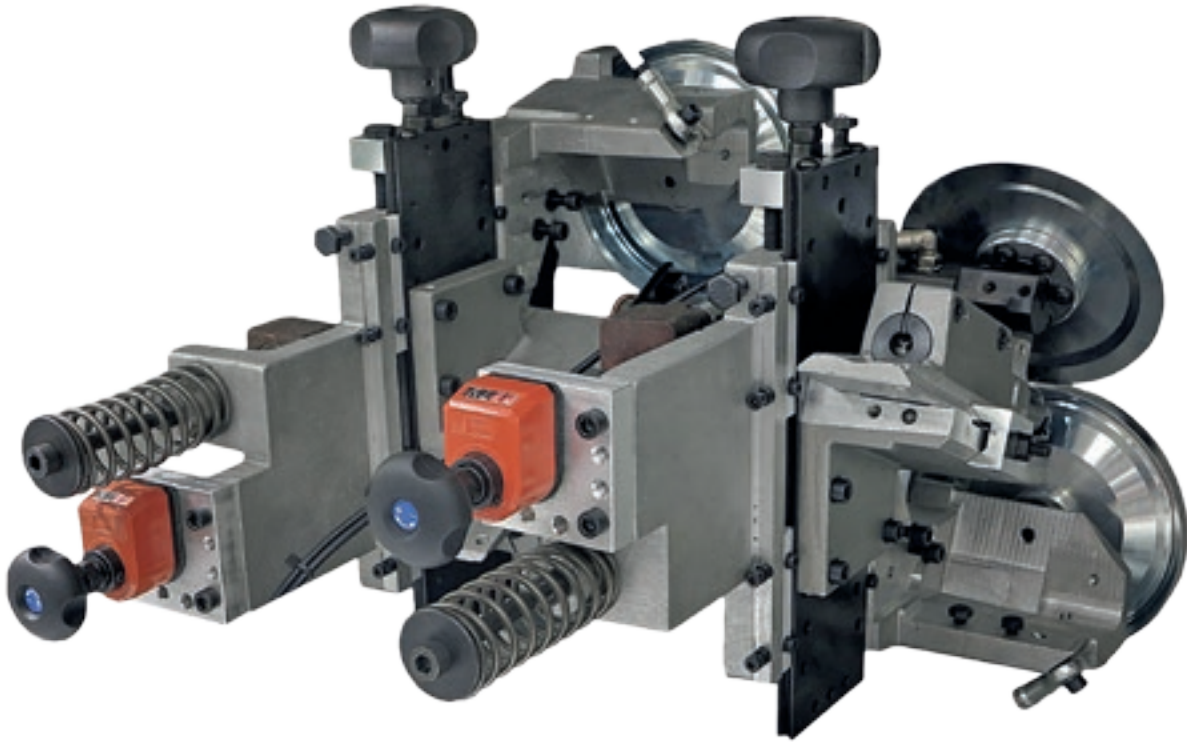

NC axes also available on the Edge Scraper, for excellent machining precision.

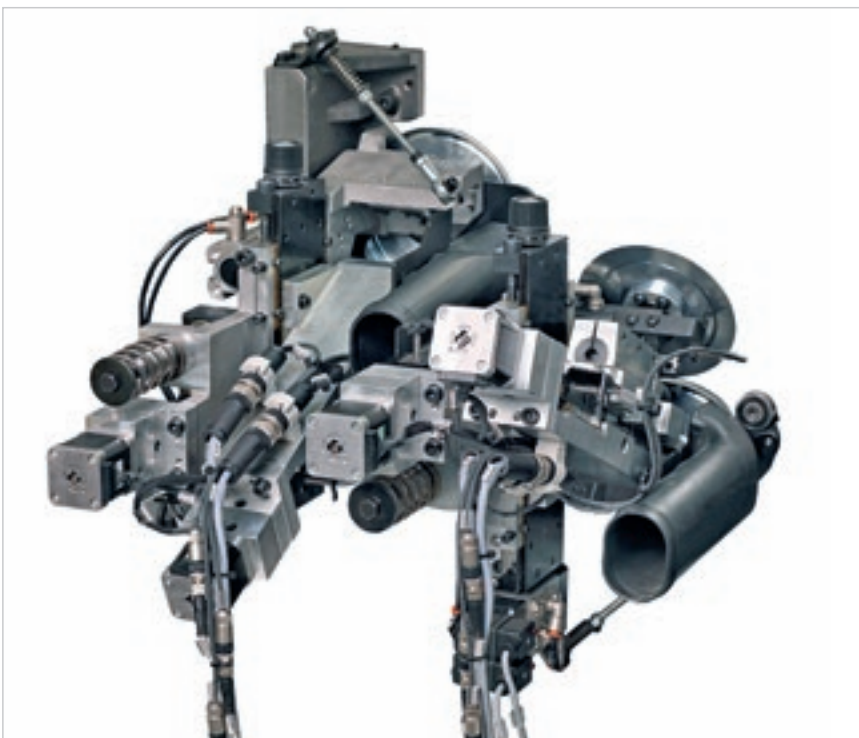

Perfect finish on every type of machining operation

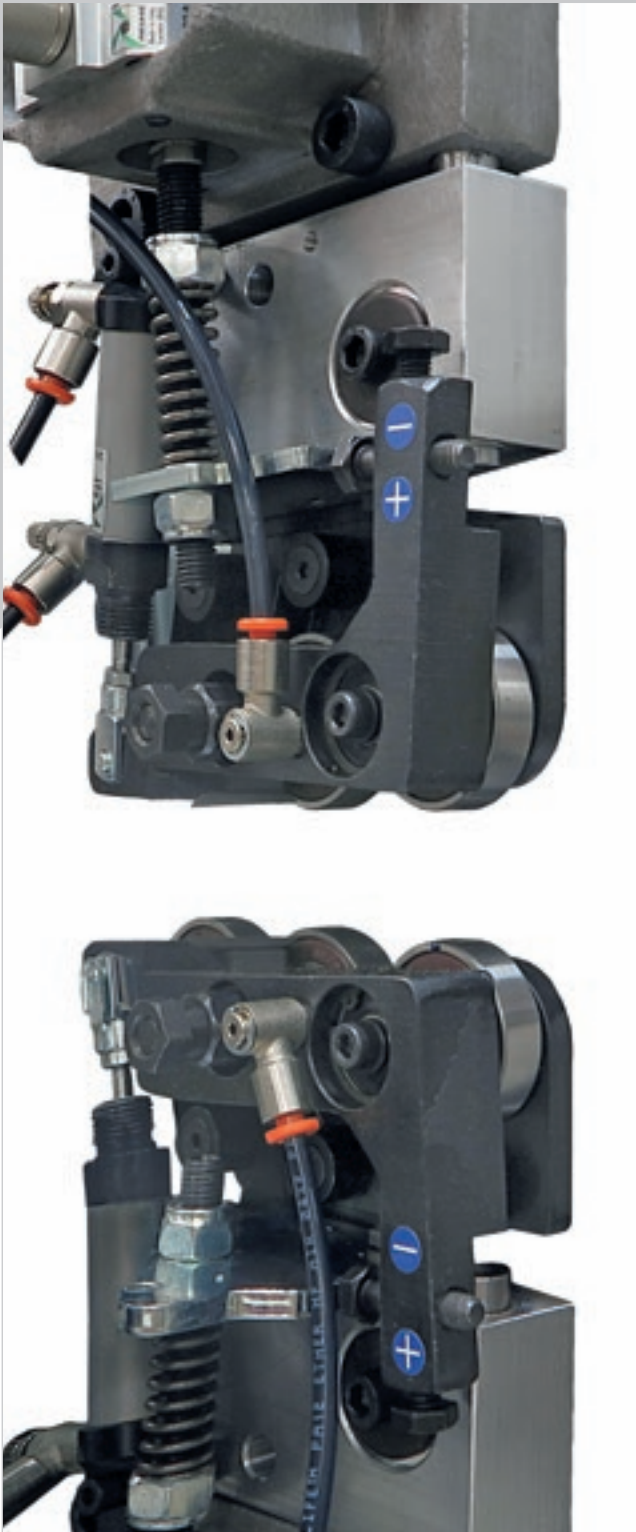

The **Glue Scraper** removes excess glue from the top and underside of the panel. This is the only model on the market fitted with 4 pneumatic cylinders for a top quality finish.



Buffing unit for cleaning and polishing the edge and panel.

Technology at the service of the user



Visualisation and management of the glue temperature of the roller and the glue pot.



Easy program management thanks to the intuitive interface, available in numerous languages.



Simple, user friendly programming thanks to the touchscreen control panel.

Technical specifications



L	
Akron 1320	mm 4168
Akron 1330	mm 5213

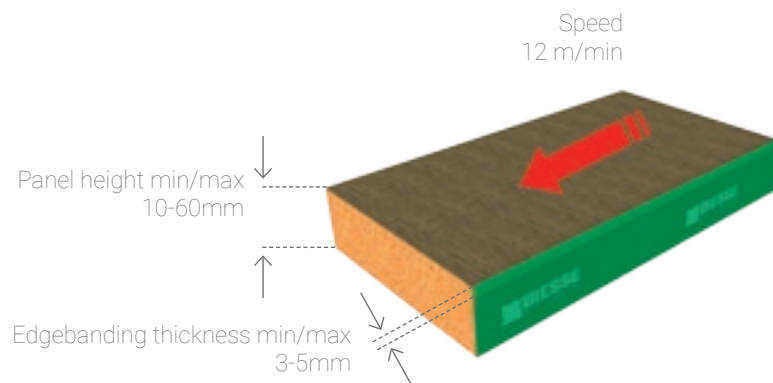

The technical specifications and drawings are non-binding. Some photos may show machines equipped with optional features. Biesse Spa reserves the right to carry out modifications without prior notice.

A-weighted sound pressure level (LpA) during machining for operator workstation on vane-pump machine LpA=86dB(A) Lwa=106dB(A) A-weighted sound-pressure level (LpA) for operator workstation and sound power level (LwA) during machining on cam-pump machine LpA=86dB(A) Lwa=106dB(A) K measurement uncertainty dB(A) 4

The measurement was carried out in compliance with UNI EN 848-3:2007, UNI EN ISO 3746: 2009 (sound power) and UNI EN ISO 11202: 2009 (sound pressure levels at workstation) during panel machining. The noise levels shown are emission levels and do not necessarily correspond to safe operation levels. Despite the fact that there is a relationship between emission and exposure levels, this may not be used in a reliable manner to establish whether further measures need to be taken. The factors determining the exposure level for the workforce include length of exposure, work environment characteristics, other sources of dust and noise, etc. i.e. the number of other adjoining machines and processes. At any rate, the above information will enable the operator to better evaluate dangers and risks.

Available configurations

Akron 1320

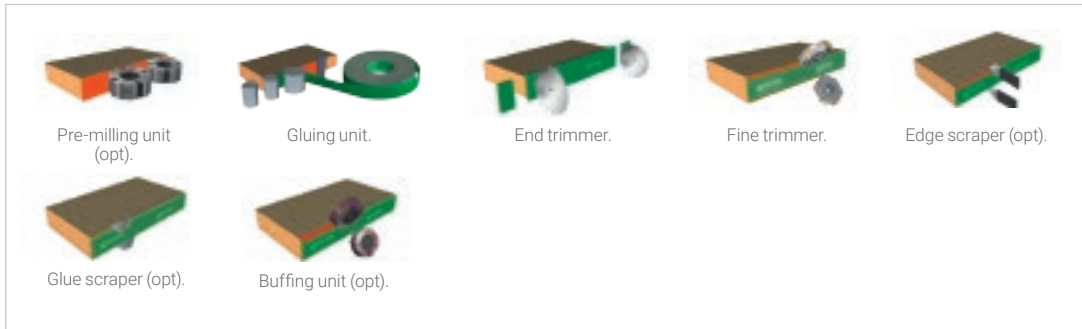

Akron 1330 - A

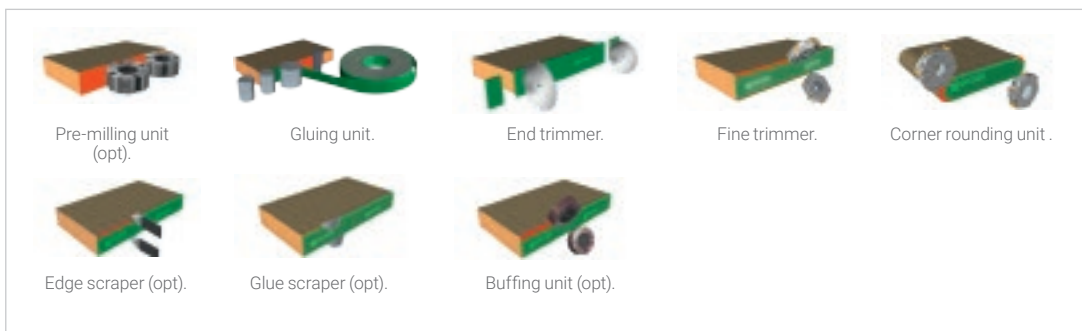

Akron 1330 - B

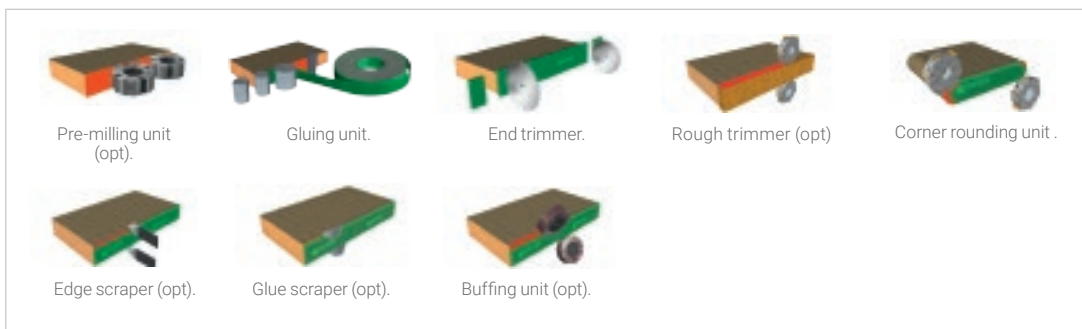

Akron 1330 - C

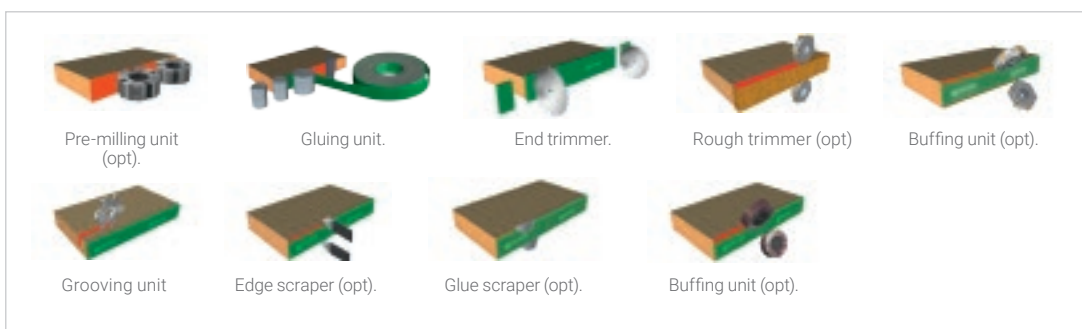

Service & Parts

Direct, seamless co-ordination of service requests between Service and Parts.
Support for Key Customers by dedicated Biesse personnel, either in-house and/or at the customer's site.

Biesse Service

- ▶ Machine and system installation and commissioning.
- ▶ Training centre dedicated to Biesse Field engineers, subsidiary and dealer personnel; client training directly at client's site.
- ▶ Overhaul, upgrade, repair and maintenance.
- ▶ Remote troubleshooting and diagnostics.
- ▶ Software upgrade.

500 / Biesse Field engineers in Italy and worldwide.

50 / Biesse engineers manning a Teleservice Centre.

550 / certified Dealer engineers.

120 / training courses in a variety of languages every year.

The Biesse Group promotes, nurtures and develops close and constructive relationships with customers in order to better understand their needs and improve its products and after-sales service through two dedicated areas: Biesse Service and Biesse Parts.

With its global network and highly specialised team, it offers technical service and machine/component spares anywhere in the world on-site and 24/7 on-line.

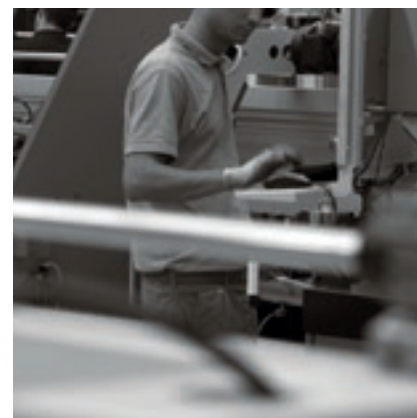

Biesse Parts

- ▶ Original Biesse spares and spare kits customised for different machine models.
- ▶ Spare part identification support.
- ▶ Offices of DHL, UPS and GLS logistics partners located within the Biesse spare part warehouse, with multiple daily pick-ups.
- ▶ Order fulfilment time optimised thanks to a global distribution network with de-localised, automated warehouses.

87%  of downtime machine orders fulfilled within 24 hours.

95%  of orders delivered in full on time.

100  spare part staff in Italy and worldwide.

500  orders processed every day.

Made **With** Biesse

Biesse technology accompanies the growth of Stechert

"On these chairs sits the world" is the motto of the Stechert Group that can effectively be taken literally. What began 60 years ago as a small manufacturing company for pram mouldings, furniture doors and door locks is today one of the largest international suppliers of contract and office chairs, as well as tubular steel furniture. Moreover, since 2011 the company has a partnership with WRK GmbH, an international specialist in podiums, conference room and grandstand seating, associated with Stechert via the joint commercial company STW. For Stechert management, however, the excellent results obtained are no excuse for resting on their laurels. On the contrary, the company is investing heavily in the Trautskirchen site to make its production even more efficient and profitable. In the search for a new machinery partner, the company's management chose the Italian manufacturer Biesse. "For the project we chose machines that already had certain options and were predisposed for automation", said Roland Palm, Biesse Area Manager.

An efficient production cycle was created in which workers are able to perform at their best after only a short training period.

At the start of the production line is the panel saw "WNT 710" with one cutting line. "Because", explained skilled cabinet maker Martin Rauscher, "we want to be able to work panels of up to 5.90 metres in order to reduce waste as much as possible." Normal rectangular panels for tables or wall panels are taken directly to the "Stream" edgebander with "AirForceSystem" technology. The Biesse edgebander has a group that activates the laminated edging material no longer via a laser beam but using hot air to obtain the so-called "zero gap". "The quality is just as good as the laser system, if not even better: with a connection power of 7.5 kW, the cost per square metre is much lower", underlined the Biesse Area Manager.

"We want to be ready for when we mould the frame ourselves and we must therefore calibrate the panels" said Martin Rauscher, "The same is true of course

for solid wood and multiplex panels, which require grinding before being painted in an external company. For both types of work a Biesse "S1" sander is used. In order to meet the needs of the future, in the Trautskirchen plant there are also two Biesse numerically controlled machining centres: a "Rover C 965 Edge" and a "Rover A 1332 R", which are perfectly complementary.

The Stechert Group also intends to strengthen sales of innovative solutions for interior fittings, with complete systems for walls, ceilings, floors and mezzanines. For panel sectioning, the Group has purchased a "Sektor 470". For other geometry, groove and spring machining as well as boring and surface milling, there are two Biesse machining centres, an "Arrow" for nesting applications, a "Rover B 440" and more recently a 5-axis machine, the "Rover C 940 R" machining centre in order to be able to produce, in particular, wall and ceiling panels machined in 3 dimensions.

Source: HK 2/2014



<http://www.stechert.de>



Biesse Group

In

1 industrial group, 4 divisions
and 9 production sites.

How

€ 14 million p/a in R&D
and 200 patents registered.

Where

37 branches and 300
agents/selected dealers.

With

customers in 120 countries (manufacturers of furniture,
design items and door/window frames, producers of ele-
ments for the building, nautical and aerospace industries).

We

3,800 employees throughout the world.

Biesse Group is a multinational leader in the
technology for processing wood, glass, stone,
plastic and metal.

Founded in Pesaro in 1969, by Giancarlo Selci,
the company has been listed on the Stock
Exchange since June 2001.

 **BIESSEGROUP**

 **BIESSE**

 **INTERMAC**

 **DIAMUT**

MECHATRONICS

