

# Handling

Handling systems

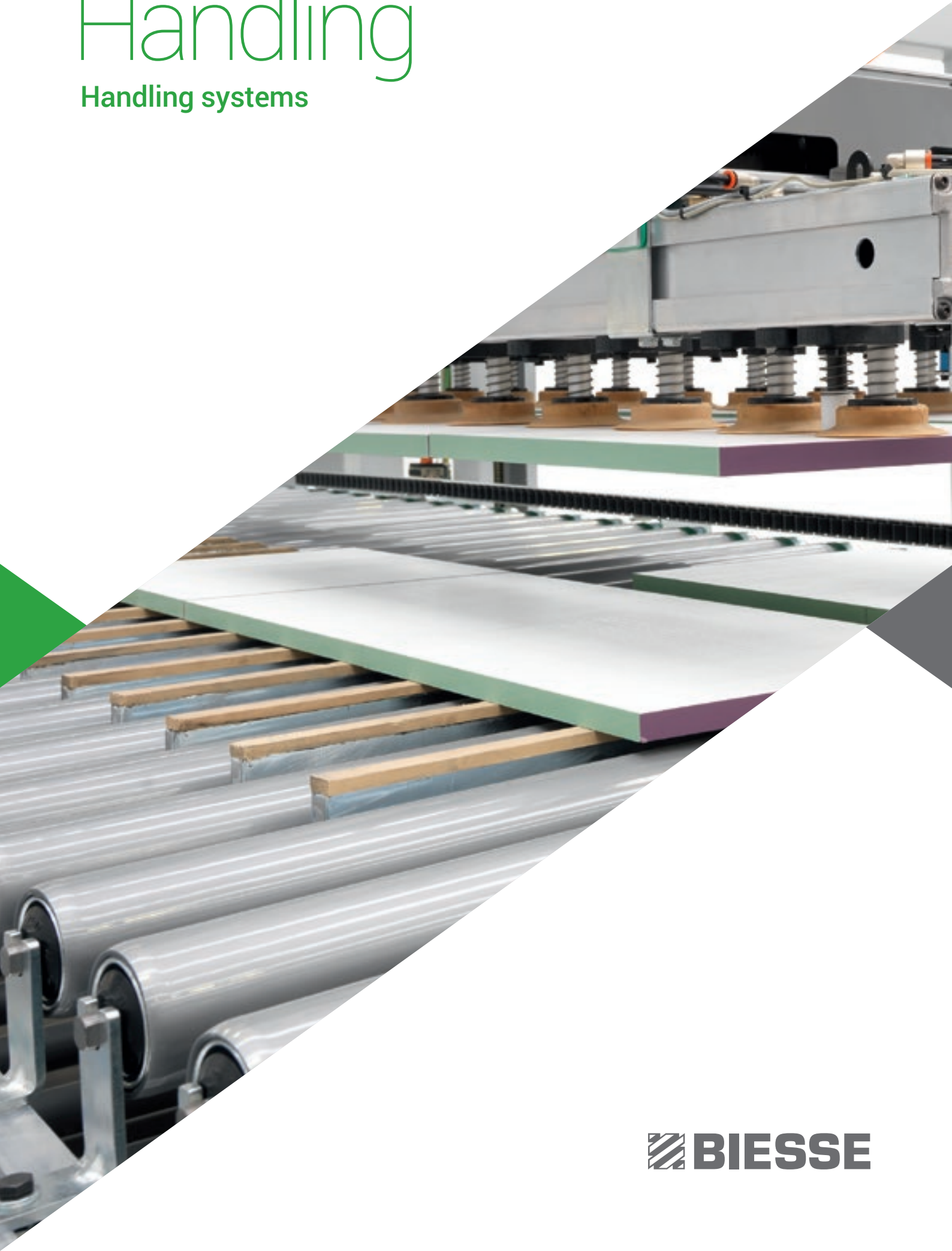

 **BIESSE**

# When competitiveness means reliable integrated logistics

Made **In** Biesse

## The market demands

a change in manufacturing processes that enables **companies to accept the largest possible number of orders**. This is coupled with the need to maintain high quality standards and high **productivity, with quick and definitive delivery time scales**.

## Biesse meets these requirements

with **technological solutions** that enhance and support technical expertise as well as process and material knowledge. Thanks to the wide-ranging expertise developed in finding the most appropriate solution to individual customers' specific requests, **Biesse** offers a comprehensive range of highly reliable and highly engineered **panel handling systems** that can be seamlessly integrated into any machining cell.

- ✓ **System efficiency.**
- ✓ **Seamless integration.**
- ✓ **Perfect synchronisation.**
- ✓ **Factory optimisation.**
- ✓ **Reduction of manual operations.**
- ✓ **High flexibility.**

Complete  
customisation  
for every process

Handling  
handling systems



# System efficiency

High performance and productivity



Winner W1



**WinnerW1** is the range of panel loading and unloading systems for **high-performance, automated lines** that is particularly suited to square-edge banding and boring lines. Flexible configurations that can be customised depending on customer logistic set-up.

**99.8% manufacturing process guaranteed reliability.**

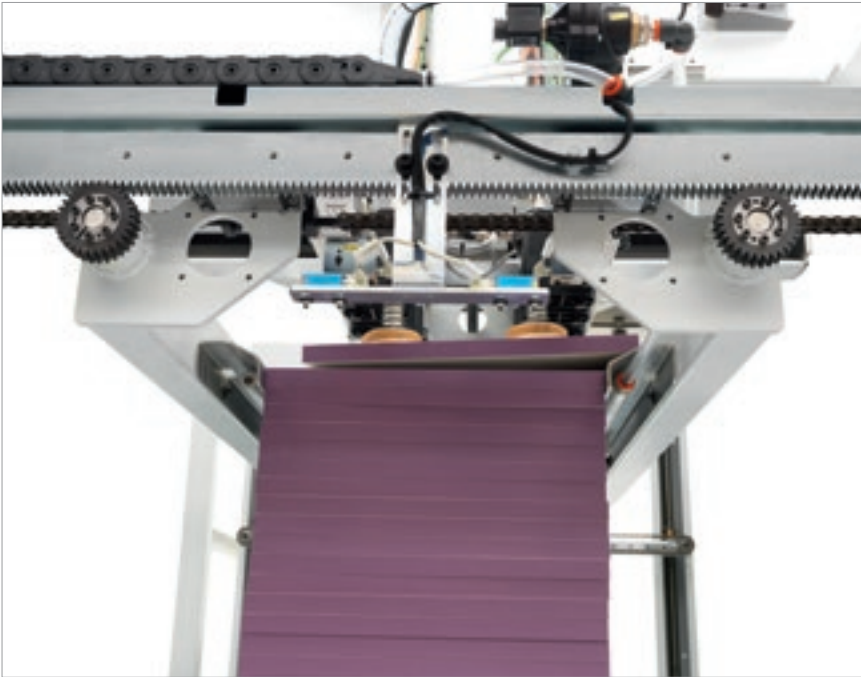

Reliable and guaranteed piece detachment, for panel stacks in single or double rows in width. The system consists of slanted blades with an integrated air jet, which, apart from ensuring panel detachment, guarantees the alignment of the panel stack at picking stage.



## High productivity up to 1000 pieces per shift.

Seamless integration and full customisation in flexible square-edging processes. Automatic management of panel tracking on the line.

# Guaranteed reliability coupled with a compact footprint



Winner W2



**Winner W2** is the solution for medium-high performance loading and unloading lines, where high handling speed and security of panel detachment are the pre-requisites for loading continuity. Ideal for flexible **boring processes**, where required productivity is of 22-26 panels per minute.

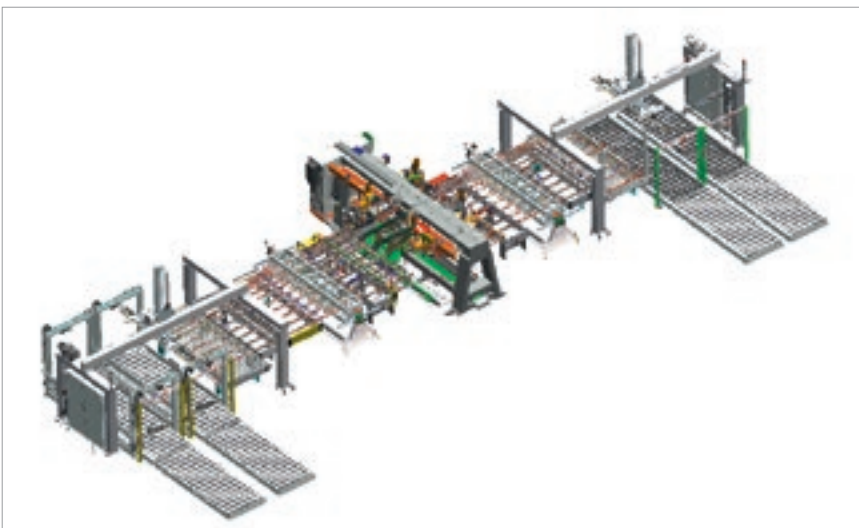



Guaranteed efficiency and reliability thanks to automatic set-ups and a piece detachment system for any type of panel stacks, both single or double-row. It consists of slanted blades with integrated air jet, which, apart from ensuring panel detachment, guarantees the alignment of the panel stack at picking stage.

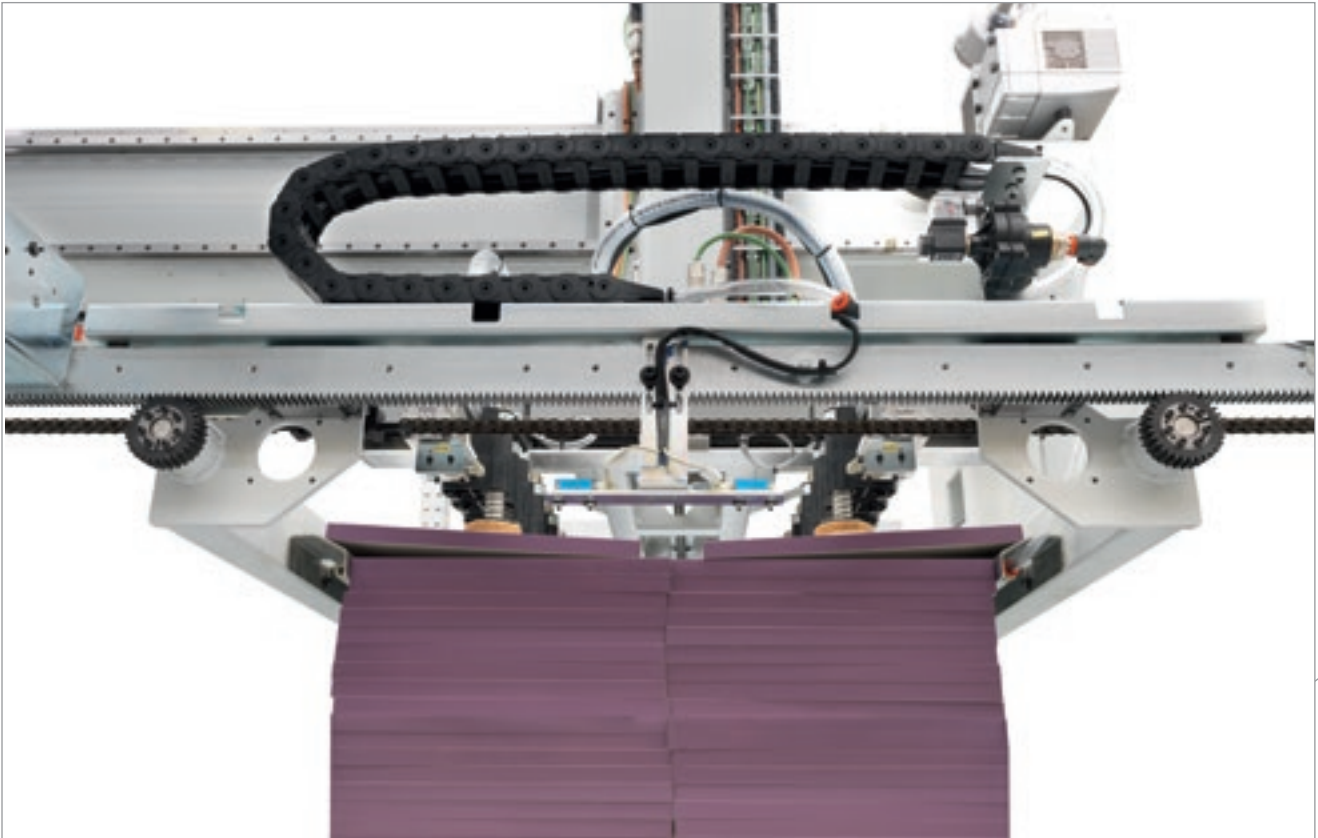

Automated management system for loading panels in double rows. It guarantees perfect production line timing.

# High flexibility



Winner W3 allows loading and unloading panels in lines with high machining flexibility to manage project stacks.

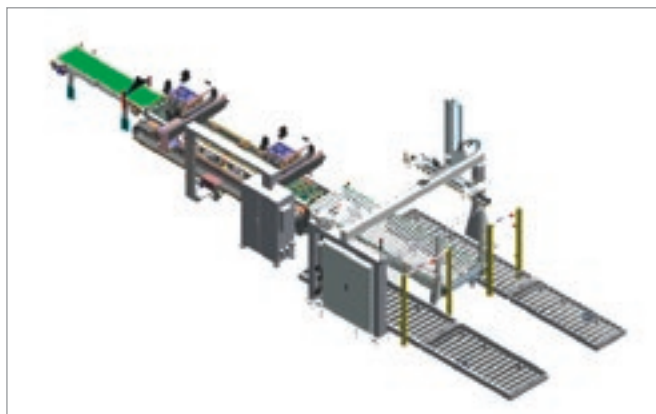

# Seamless integration of flexible edgebanding

Productivity of up to 600  
pieces per shift.



The **Winner W4** loading system can be perfectly integrated with single-sided edge banding machines, allowing operators to automatically manage the handling of the panels to be edgebanded. The graphical interface is extremely intuitive and easy to use, with an innovative touch-screen panel.



The sensors for the detection of the panel render the machine completely independent.



Withdrawal system for recirculation and unloading of panels with rotation. Automatic positioning via the dimension detection system.

# Perfect synchronisation



Lifter L1

Gripper unloading system for **high-productivity angular cutting systems**. Integrated software management for the perfect synchronisation between cutting scheme and unloading configuration.

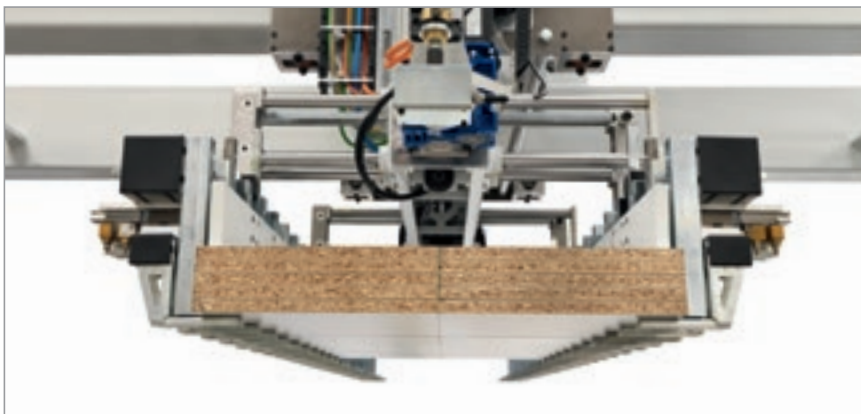

The gripper frame with pressor ensures grip over both single and double-row packs.



Customising the machine with a suction cup frame enables processing bars for sectioning.

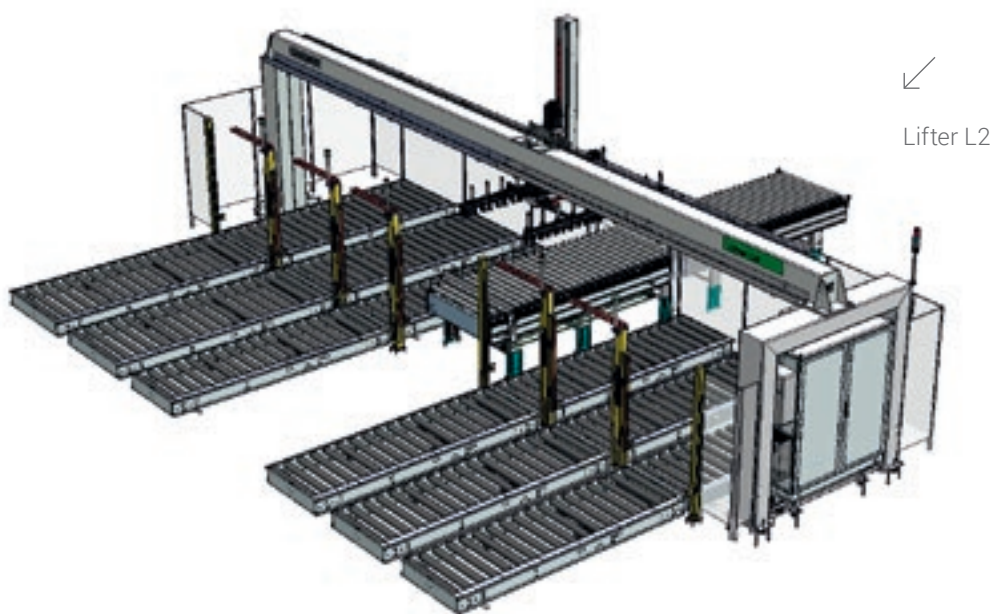

Suitable for angular and mono-line cutting processes, for panel saws with blade protrusion up to 135 mm. Extremely quick and flexible, guarantees the management of several sub-formats.



Unloading operation assisted by technical and visual information that supports correct flow in line with customer's logistics.

# Factory optimisation

Winstore is an automated magazine for the optimised management of panels for large contract manufacturers, which guarantees production with reduced times and costs. Winstore can be integrated into nesting and sizing cells with a significant increase in productivity.



Integrated software management of the entire system between customer's management system and manufacturing process.



## **Winstore K1**

Magazine for high productivity and flexibility. Suitable for uploading and unloading several operating machines integrated into the same line. Seamless integration with panels saws and nesting CNCs. It ensures precise detachment also for breathable and thin panels.



## Winstore K2

Integrated magazine for machining cells with panel saws or nesting CNCs.



## Winstore K3

Integrated magazines for mono-line panel saws. Its reduced footprint makes it particularly suited to cells where space is at a premium. Increase of machine efficiency thanks to the reduction in manual loading operations.



Winstore can also be integrated with a flexible panel saw for **batch-one** machining processes.

# Return on investment within 1 year

Production line performance increase of up to 25% when working in real time processing.



The Winstore automated magazine **stacks panels of different sizes and materials**, including mixed ones, with no need for operator intervention. The reorganisation of panel magazine and stacking can be carried out automatically, out of working hours.



35% reduction of product delivery time compared to conventional solutions.

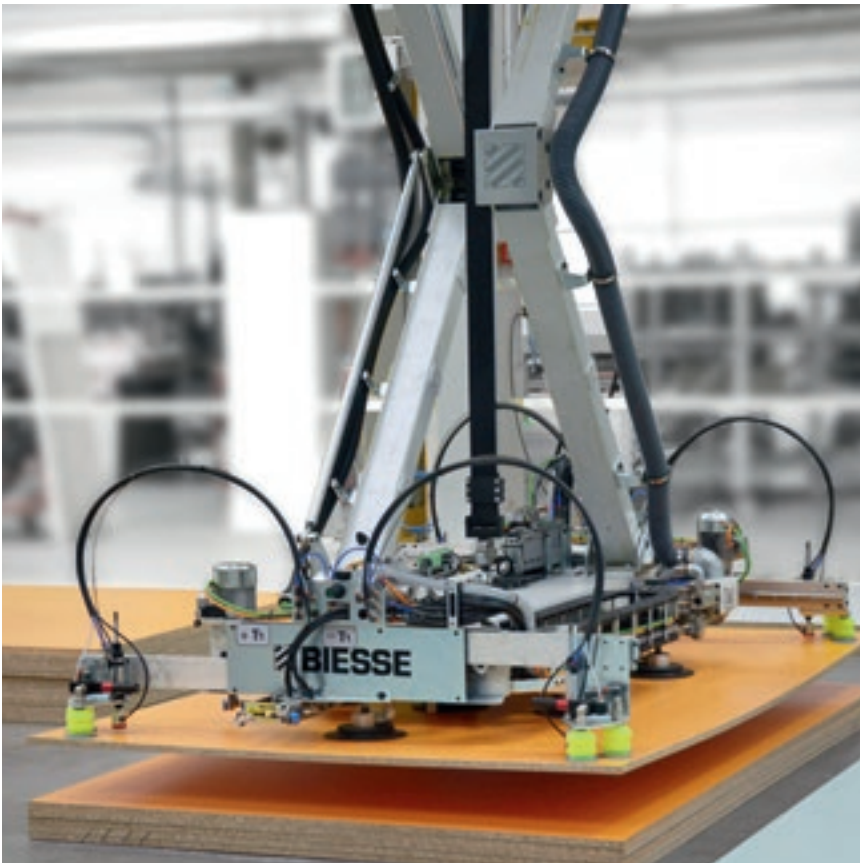

Magazine mapping is fully optimised thanks to management by the system supervision software. It can be installed in areas with limited height, supporting high system performance and ensuring maximum panel stability.



10% reduction in raw materials compared to conventional production handling methods.



The **rotating panel pick-up system** and **squaring laser photocells** optimise the magazine internal area, enabling the perfect alignment of the stack as well as correcting manual loading errors.



Waste reduction



Greater efficiency of floor and storage space due to the management of multi-sized and multi-coloured stacks.



30% labour reduction.

# High, constant performance



### Turner PT

Turner PT panel turners are ideal for high-productivity square-edging lines. 90° rotation achieved using two padded, motorised inverter-controlled cones.

They allow processing and synchronisation time between the first and the second run of the two squaring and edgebanding machines on the line.



### Turner OT

Panel transportation system for the boring process. It allows panels to be turned by 180°.



# Special solutions



## Robots

High customisation of loading and unloading cells. Ideal for rail boring-insertion lines. Seamlessly integrated with CNC for the machining of doors with waste and strip management.

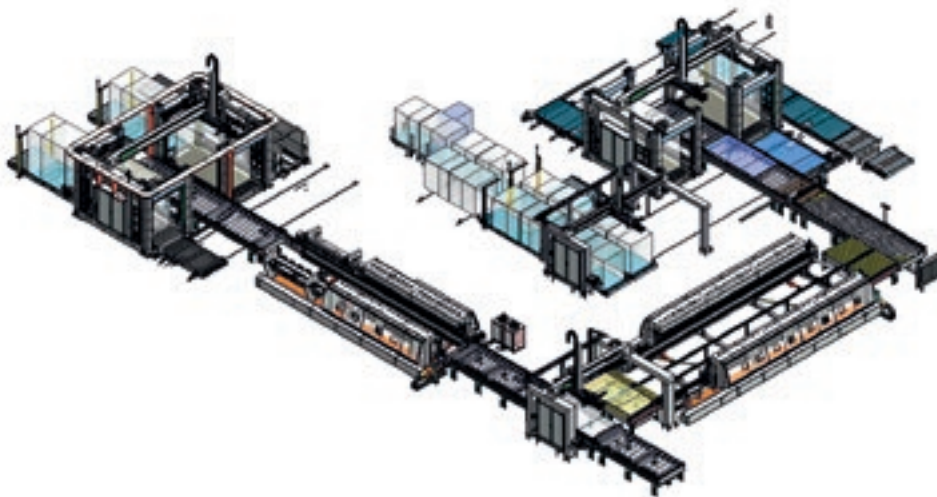

## Winner T1

Specialised high-productivity system for machining doors. With superior versatility, the Winner can be integrated into specialised lines, guaranteeing both reliability and productivity.

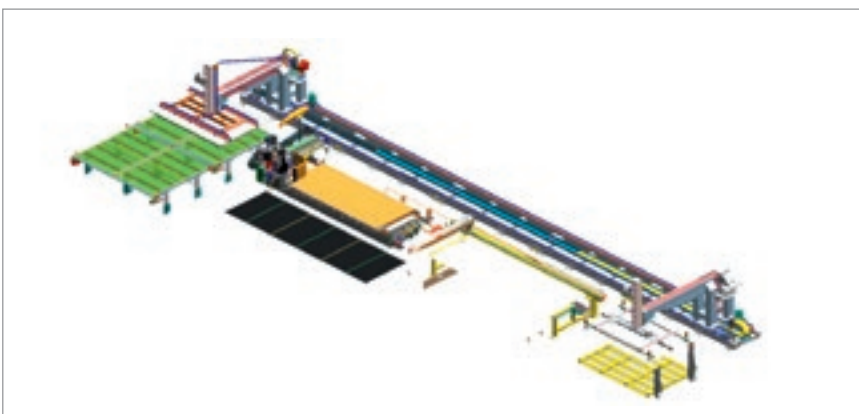

## Winstore 2D

Special loading and unloading system for CNC for nesting machining operations. It prevents panels with delicate surfaces from scraping over the work table.

# Competitive customisation

Biesse Systems is a team of highly trained engineers for large scale production processes. Biesse Systems offers integrated cells and systems that are capable of maximising customer competitiveness by combining mass production techniques with a high degree of customisation to meet customers' exact requirements.



## PRODUCTION LINES

Made-to-measure turnkey factories, plus the integration of Biesse Group solutions with complementary software and machinery, with over 300 systems installed worldwide. A perfect combination of Biesse Group's experience and Italian genius.

# Information flow integration

## Supervision software.

Biesse supplies an integrated software program for the management (handling, identification and labelling) of panels to be processed, as well as waste material and off-cuts which can be recycled for new products.

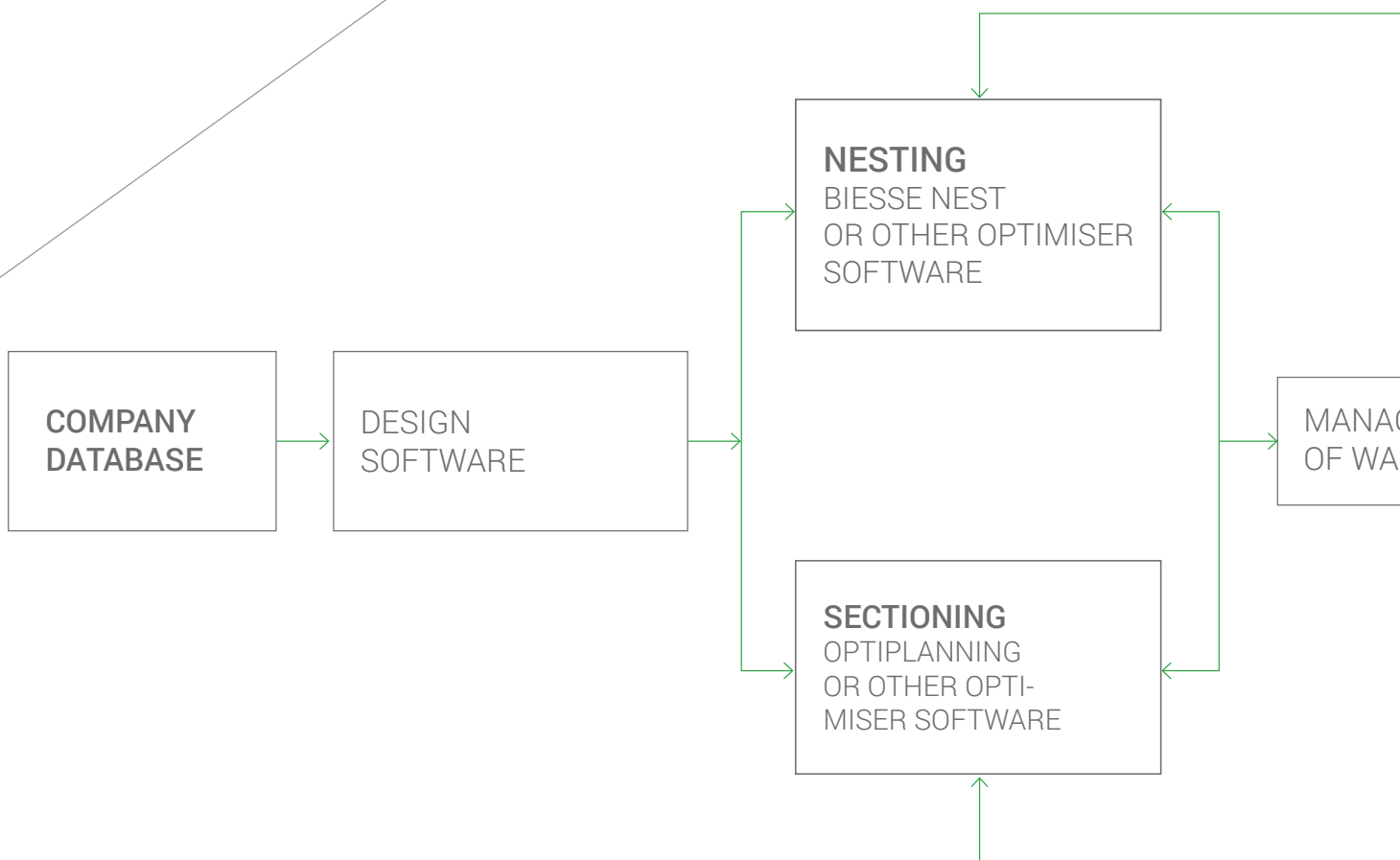

Full integration of cell software with plant enterprise management system.

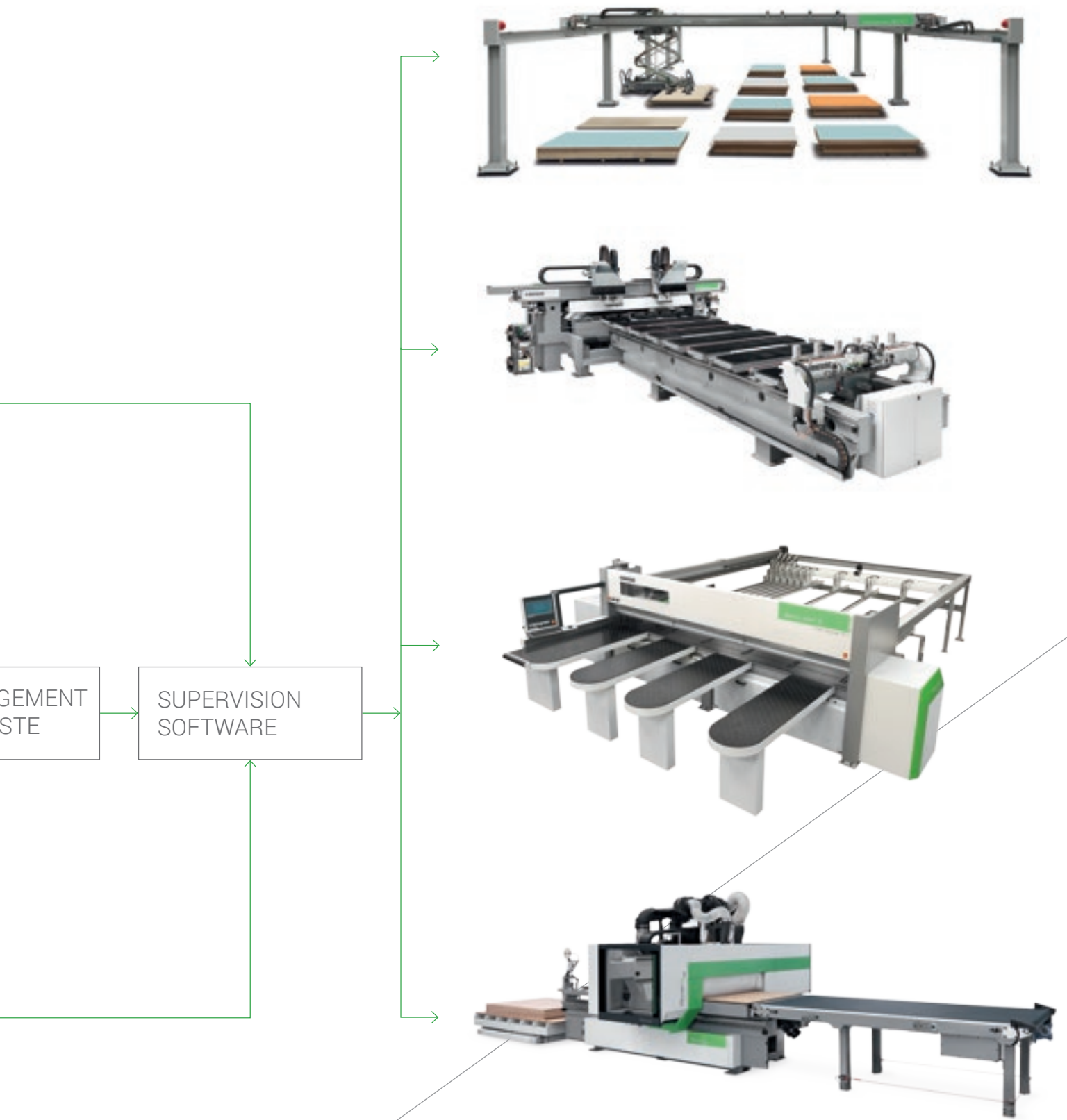

# Service & Parts

Direct, seamless co-ordination of service requests between Service and Parts.  
Support for Key Customers by dedicated Biesse personnel, either in-house and/or at the customer's site.

## Biesse Service

- ✓ Machine and system installation and commissioning.
- ✓ Training centre dedicated to Biesse Field engineers, subsidiary and dealer personnel; client training directly at client's site.
- ✓ Overhaul, upgrade, repair and maintenance.
- ✓ Remote troubleshooting and diagnostics.
- ✓ Software upgrade.

500 / Biesse Field engineers in Italy and worldwide.

50 / Biesse engineers manning a Teleservice Centre.

550 / Certified Dealer engineers.

120 / Training courses in a variety of languages every year.



The Biesse Group promotes, nurtures and develops close and constructive relationships with customers in order to better understand their needs and improve its products and after-sales service through two dedicated areas: Biesse Service and Biesse Parts.

With its global network and highly specialised team, it offers technical service and machine/component spares anywhere in the world on-site and 24/7 on-line.



## Biesse Parts

- ✓ Original Biesse spares and spare kits customised for different machine models.
- ✓ Spare part identification support.
- ✓ Offices of DHL, UPS and GLS logistics partners located within the Biesse spare part warehouse, with multiple daily pick-ups.
- ✓ Order fulfilment time optimised thanks to a global distribution network with de-localised, automated warehouses.

87% / of downtime machine orders fulfilled within 24 hours.

95% / of orders delivered in full on time.

100 / spare part staff in Italy and worldwide.

500 / orders processed every day.

# Made **With** Biesse

**Biesse Group technology supports the manufacturing efficiency of the world's largest furniture manufacturers.**

"We were looking for a solution that would be so innovative that it would satisfy all our needs at the same time," states the manufacturing manager of one of the world's largest furniture manufacturers. "Most of our production was already made using numerical control tools, but now everything that we produce is made with these technologies. This is why it was necessary to increase our production capacity. Biesse offered a solution that we liked very much, an

authentic line of processing centres and automatic magazines. Innovative, fascinating and decidedly powerful. With Biesse we defined a "turnkey" solution to be planned, built, tested, installed, inspected and commissioned within a precisely defined schedule.

*Source: excerpt from an interview with the manufacturing manager of one of the world's largest furniture manufacturers.*



# Biesse Group

In

1 industrial group, 4 divisions  
and 8 production sites.

How

€ 14 million p/a in R&D and 200 patents registered.

Where

34 branches and 300 agents/selected dealers.

With

customers in 120 countries (manufacturers of furniture,  
design items and door/window frames, producers of ele-  
ments for the building, nautical and aerospace industries).

We

3,200 employees throughout the world.

**Biesse Group** is a multinational leader in the  
technology for processing wood, glass, stone, plastic  
and metal.

Founded in Pesaro in 1969, by Giancarlo Selci, the  
company has been listed on the Stock Exchange  
(STAR segment) since June 2001.

 **BIESSEGROUP**

 **BIESSE**

 **INTERMAC**

 **DIAMUT**

**MECHATRONICS**

