

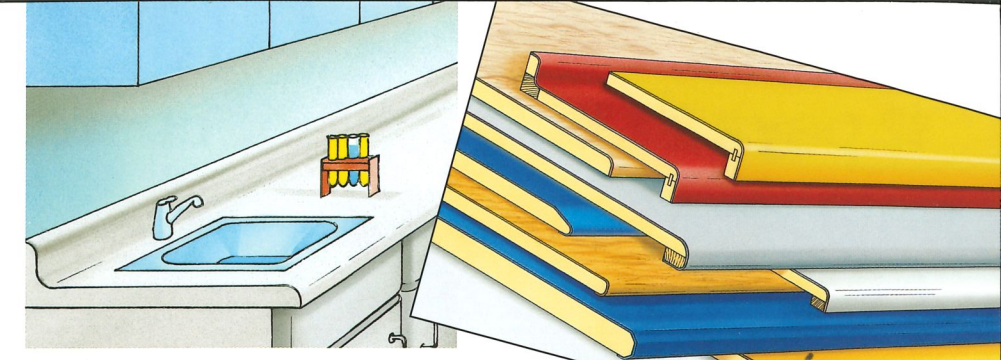

Postforming Machine Optimat PF 20/31

Patented postforming
process with maximum
efficiency

Cycle type postforming, flexible and economic for all factory sizes



Patented postforming procedure

The Brandt cycle type postforming machines of the PF-series are well-approved and extraordinarily successful in their range of application, on one hand in craftsmen' workshops and small and medium-sized industrial enterprises on the other hand in larger enterprises for the production of single components and small to medium batches on an extremely economical basis.

Decisive advantages:

- **Uninterrupted covering of surface and edge**
 - Topic furniture design
- **Great variety of surface materials**
 - Decorative high pressure laminates
 - Natural veneers
 - All formable laminates
- **Universal field of application**
 - Both, single components and large series are economically processed
- **Safe gluing**
 - PVAc glue or UF resin
 - The pressure bar is following any positive profile and thus ensures a safe gluing, also at critical points
- **Many different profiles and radii**
 - without the use of templates

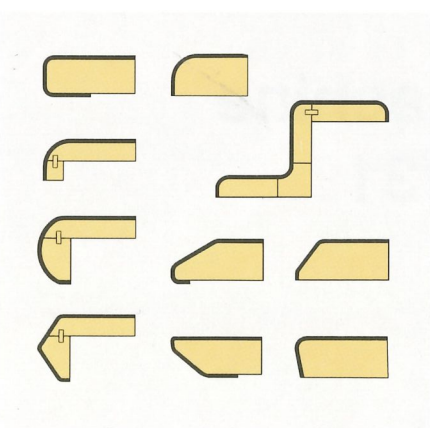
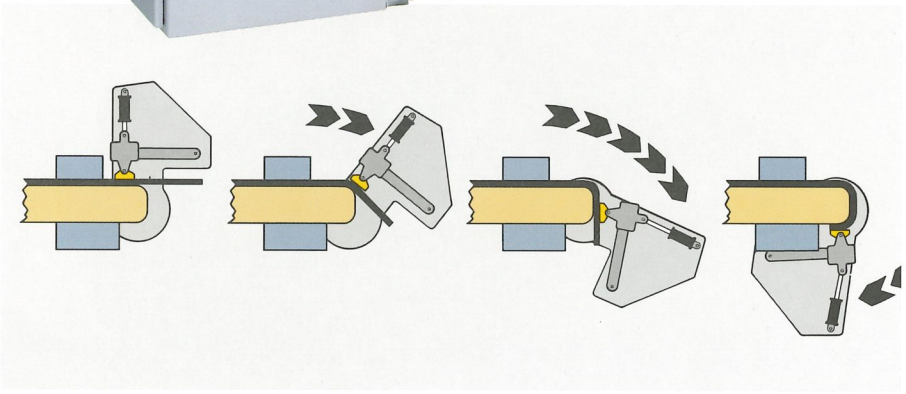
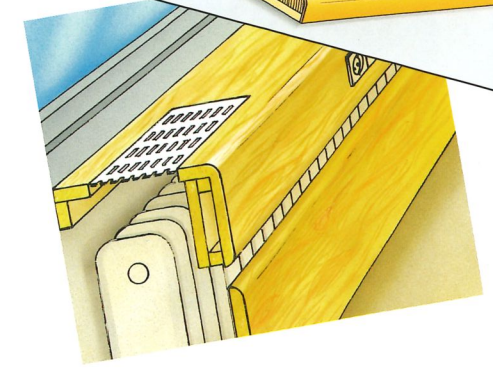
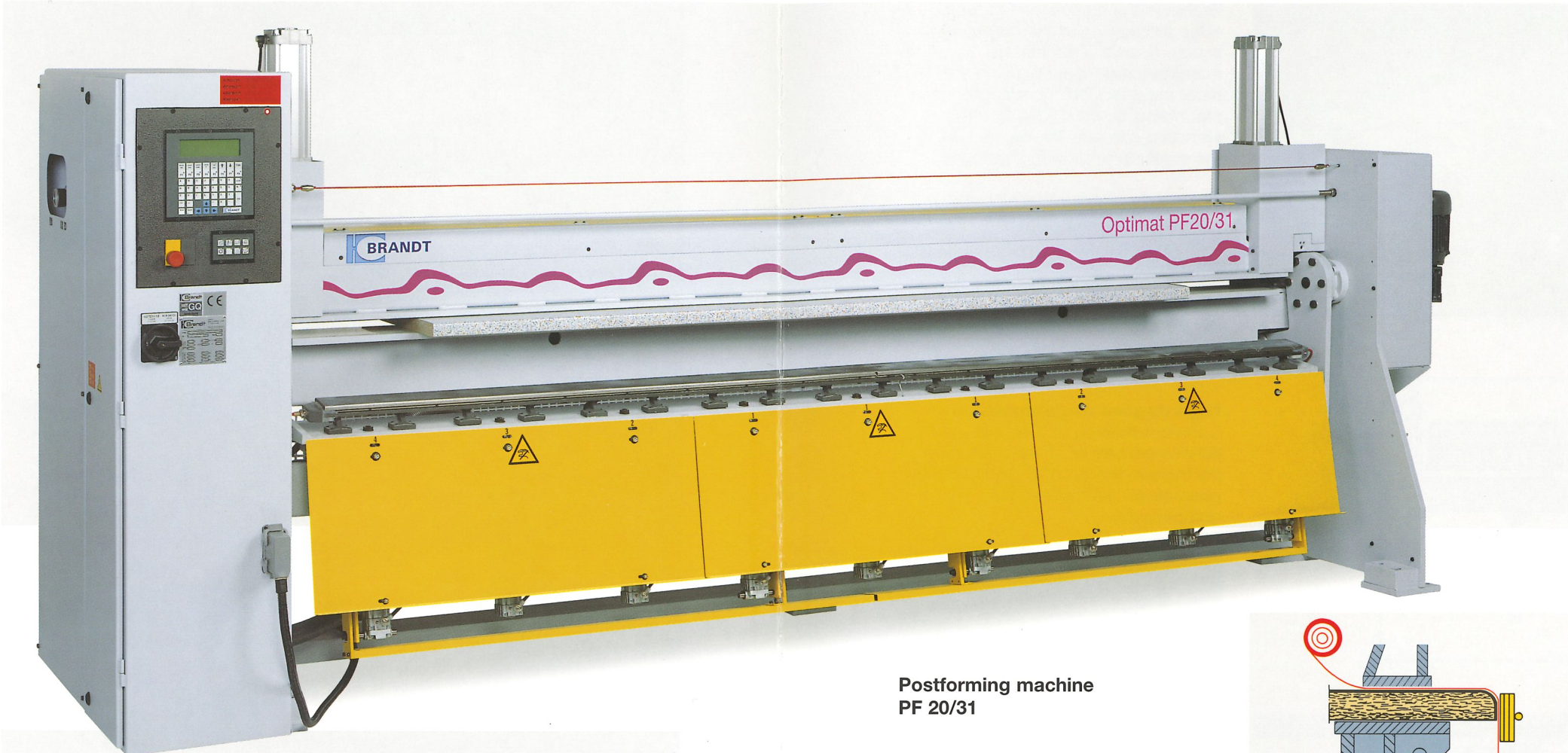

The postforming technology
Once the profiled workpiece with laminate pressed to the surface has had adhesive applied with a spray gun, the machine forms the surface material with the patented and heated forming/pressure rail. The contact heat makes the laminate bendable and activates the glue. The heating rail follows the workpiece profile while under continuous pressure and glues the surface material to the workpiece.

Postforming machine PF 20/31

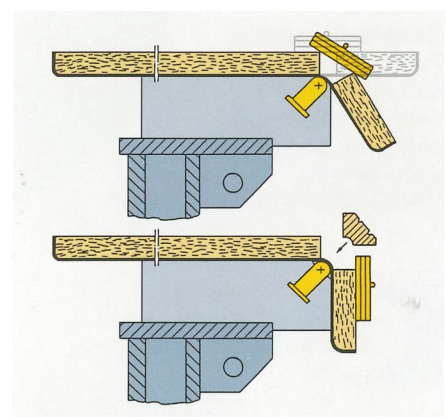

Internal radii
A special forming/heating rail is available as an option for workpiece with internal radii, as for example, work-top wall connections in kitchens or in damp rooms or laboratories.

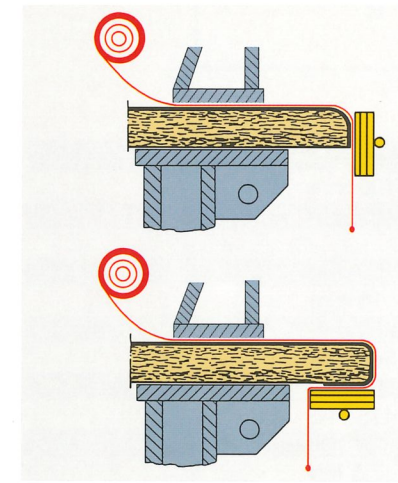

Foil device
A special foil device is available as an additional option for processing delicate laminates and veneers in order to prevent damage to the surface.

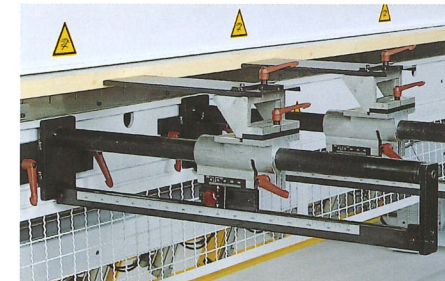

Electronic control
The new Optimat PF 20/31 is equipped with modern electronic controls as standard equipment. All setting functions can be stored in programs and revoked very quickly. These are integrated numerical program controls with a special teach-in-function and simple, user-friendly programming possibilities.

- Input unit NC 16 with a 8-line LCD display, 40 signs each
- clearly readable fault indication
- simple, interactive programmability
- comfortable administration and storage up to 120 user programs with 10 stops each
- max. 99 stops for each user program
- electronic frequency changer

Workpiece stops PF 20/31
Two adjustable workpiece stops belong to the standard execution of the machine. Also these dates are written down into the data sheet together with all other values, for shortening up the change over times.

It pays to be a Brandt customer



Brandt is the worldwide leader in edge processing in the carpentry sector. Brandt products are manufactured in series using the most modern CNC controlled machining centres. This Brandt standard can only be realised using the most up to date technologies.

Brandt is present everywhere

The well established service, marketing and agencies network means short distances for you and the closest possible vicinity to the customer - worldwide. Our marketing partners and consultants know the market problems. They are from your trade and speak your language.

High degree of competence

Constant training of the sales and service personnel of our marketing partners in the Brandt training centre guarantees optimal service competence.

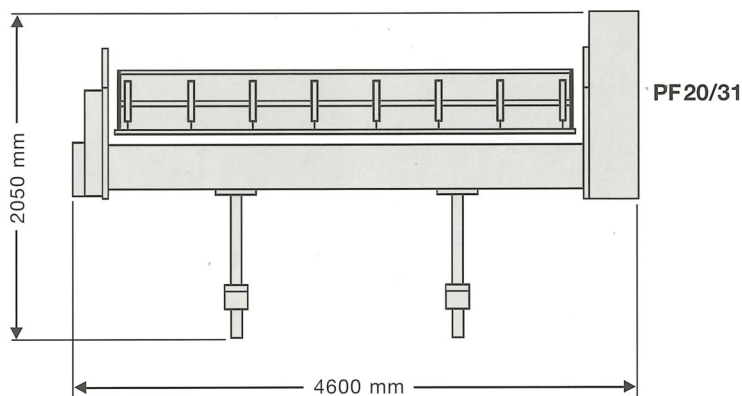

Technical data

Optimat PF 20/31

Workpiece length max	3100 mm
Workpiece length min. (single pieces)	1400 mm
Max. profile height	150 mm
Min. workpiece thickness	16 mm
Worktable height	950 mm
Total height	1850 mm
Total length	4600 mm
Weight	1750 kg
Electrics	400V-3 Ph.-50Hz (special voltage possible)
Conn. value	7,5 kW
Pneumatic value	7 bar

All rights for technical changes withheld. Individual machines shown could include options.

Your supplier,
our marketing partner:



DIN EN ISO 9001

Excellent quality

Production, service and marketing departments of the company are certified according to DIN EN ISO 9001 (TÜV CERT).



Brandt
Kantentechnik GmbH
 Weststraße 2
 D-32657 Lemgo
 Tel. 052 61/97 4-0
 Fax 052 61/64 86
 info@brandt.de
 http://www.brandt.de