

# JET 5

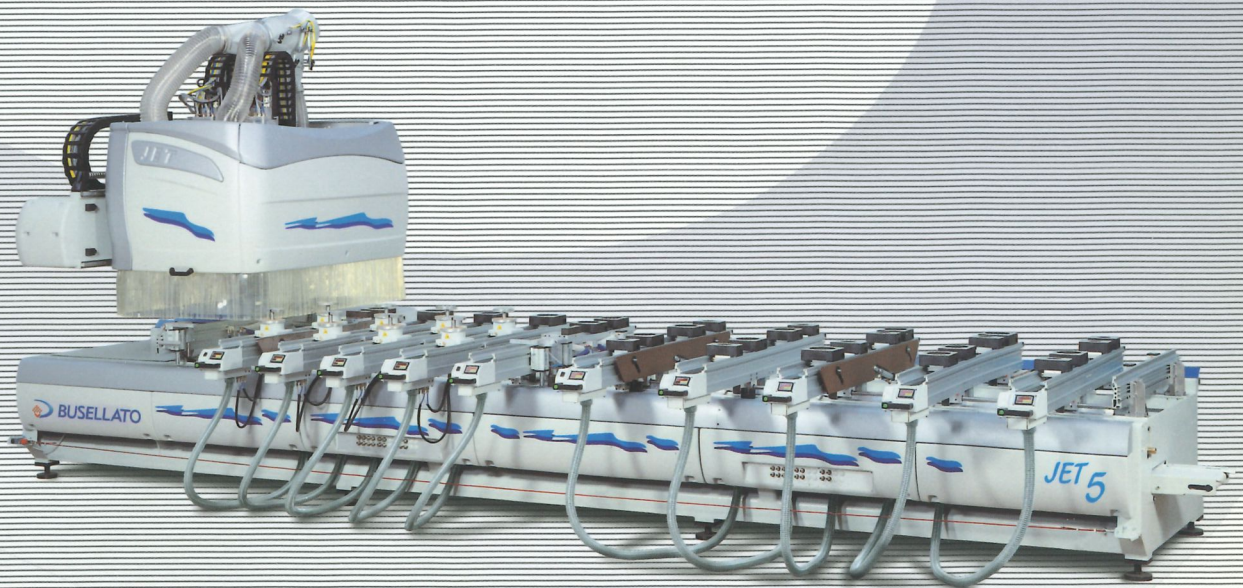

**BUSELLATO**  
cnc working centers and drilling solutions



# JET 5

## Qualità e Performance

La nuova serie JET è la sintesi di una cultura aziendale, quella Busellato, tutta orientata alla qualità, perseguita costantemente con l'impiego di materiali e componenti sicuri e ad alto contenuto tecnologico.

Il modo migliore di impiegare il vostro tempo produttivo è quello di affidarsi a macchine ben costruite, senza rinunce o compromessi sulla qualità.

Macchine che durano nel tempo, che sopportano lavorazioni intensive e che grazie alle dotazioni di base e ai più moderni sistemi di controllo assicurano la giusta flessibilità per lavorare tutto ciò che serve per il successo della vostra azienda.

## High Quality & Performance

The new range of JET working centers is the result of Busellato's quality orientated business strategy.

The pursuit of a high quality policy is shown by the use of highly technological components and severe inspection procedures. Best use of your production time means relying on strong, fast and precise machines, constructed without compromising on quality.

Busellato's machines stand up to intense use and last a lifetime. Thanks to the reliability of its components and state of the art control systems, our machines assure maximum flexibility for all your working needs.

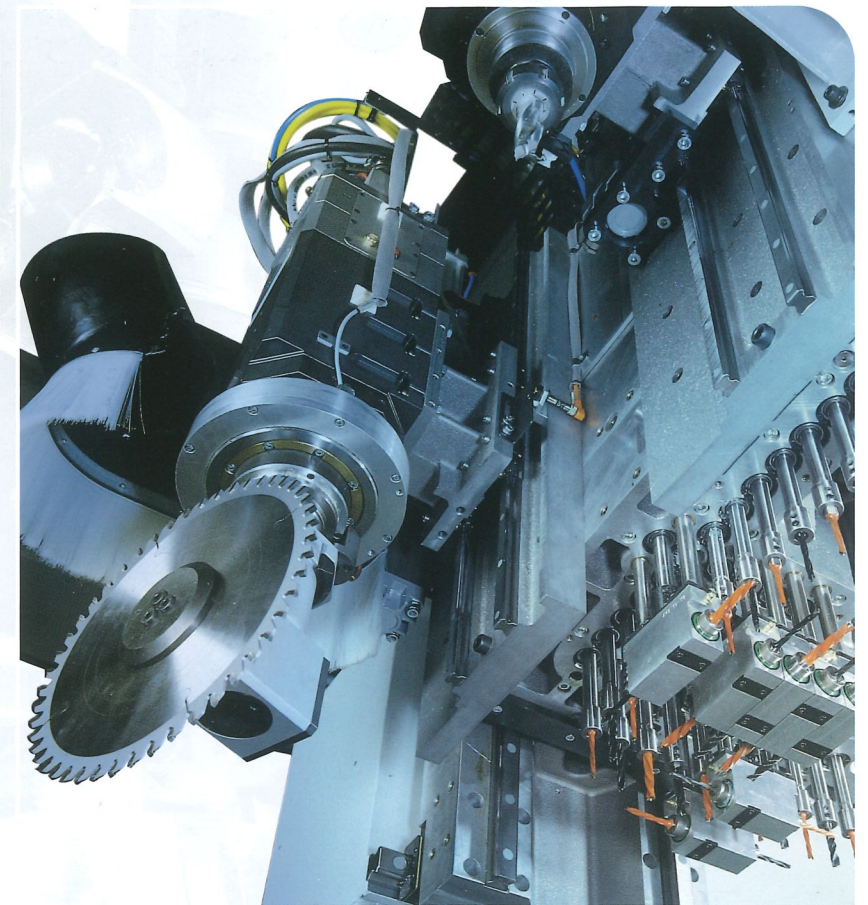
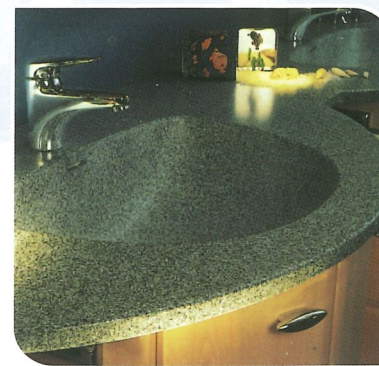

BUSELLATO is certified  
ISO 9001:2000





# IL PIANO

## Semplicità e grande flessibilità

Per la serie JET Busellato ha sviluppato varie soluzioni di piani e ventose e numerosi dispositivi di bloccaggio. I piani in alluminio sono robusti e precisi e le ventose scorrono liberamente su tutta la lunghezza.

# THE WORK BED

## Simplicity and great flexibility

For the JET series, Busellato has developed various solutions of panel supports, vacuum cups and clamping devices.

Aluminium panel supports are strong and precise. Vacuum cups move freely along the panel supports.

- Posizionamento automatico da CN di piani e ventose
- Automatic positioning by CN of panel supports and vacuum cups



- Particolare del bloccaggio ventosa
- Detail of vacuum cup locking system

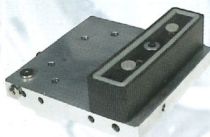
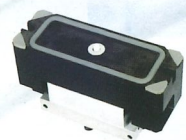
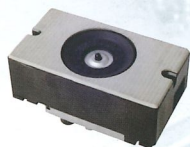
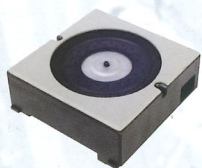
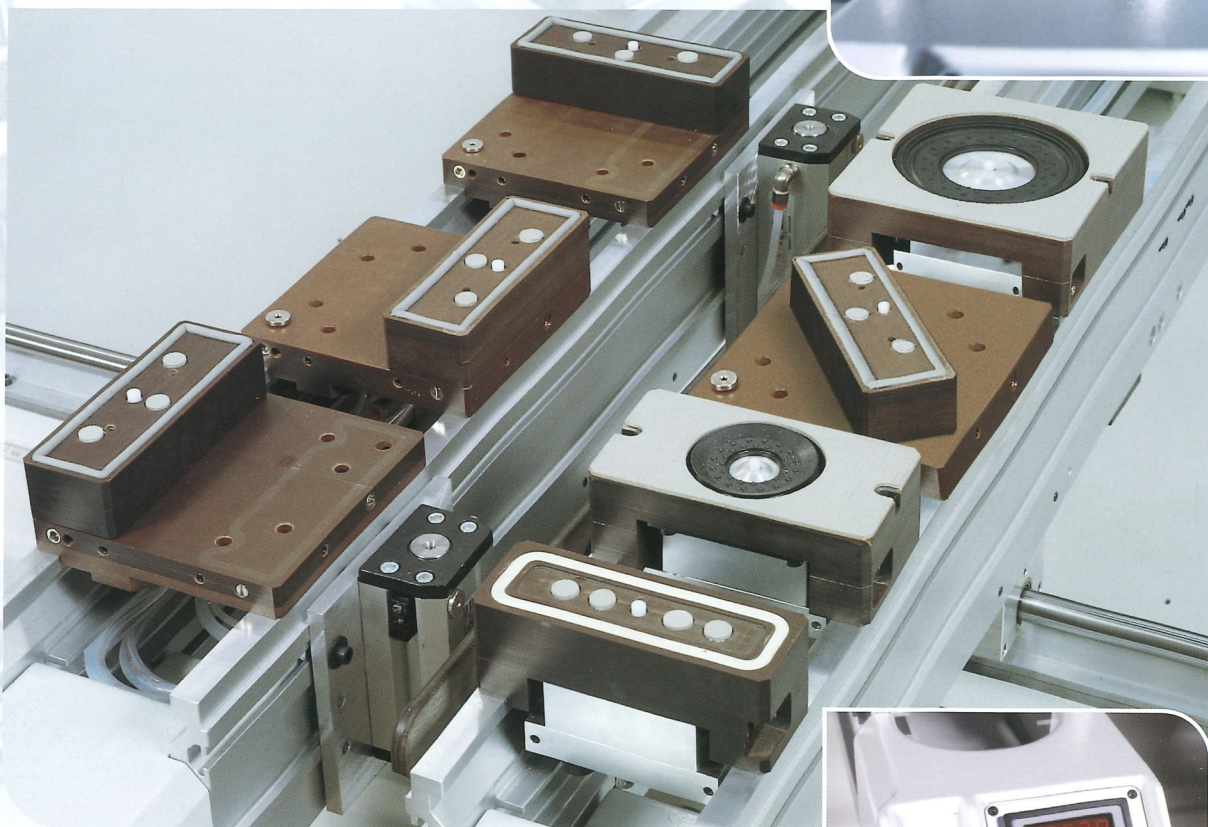
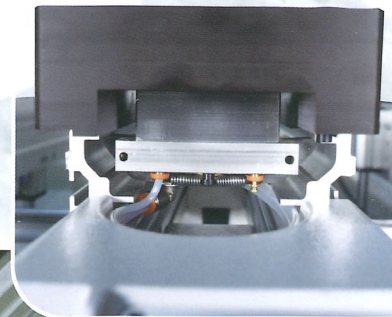

- Esempi di ventose
- Examples of vacuum cups

- Display sul piano
- Display on panel support



✓ Strong stops

✓ Double "0" line

✓ Moveable side stops

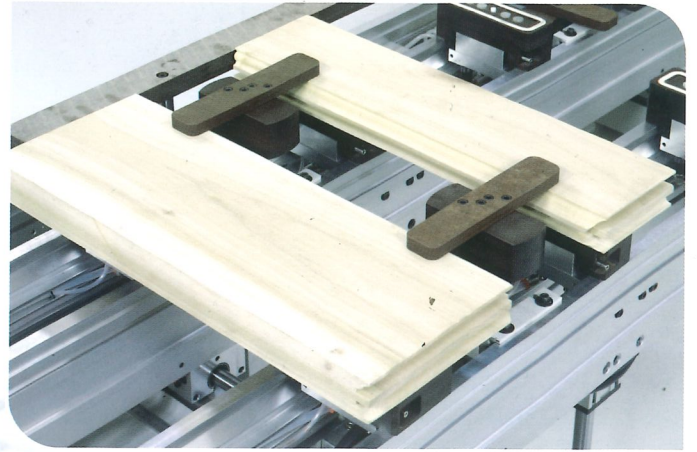

- Bloccaggi speciali
- Special clamps

- Esempi di bloccaggi
- Examples of clamping devices

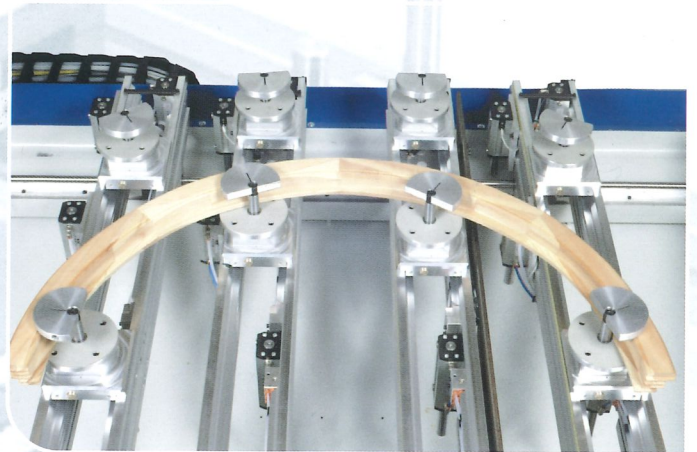
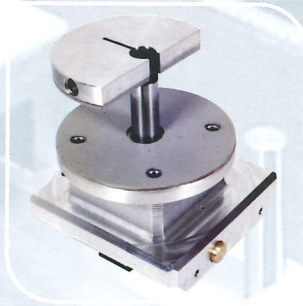

- Bloccaggi per archi
- Clamps for arched windows

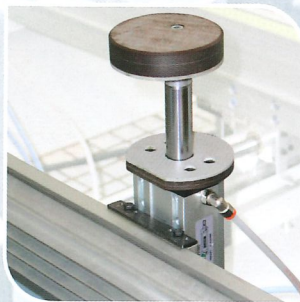

- Lavorazione con impiallacciati
- Positioning of a veneered panel

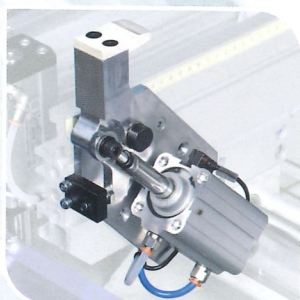

- Battute per impiallacciati
- Stops for veneered panels



- Sollevatori per pannelli pesanti
- Feeding rails for heavy panels



# IL PIANO PANTOGRAFO

- ✓ Varie misure di piano
- ✓ Nesting a tutto piano
- ✓ 4 aree di lavoro
- ✓ Battute posteriori, laterali e centrali
- ✓ Piano lavorato sulla macchina per assoluta precisione
- ✓ Utilizzo di ventose rialzate per lavorazioni orizzontali
- ✓ Dispositivi evacuatori



# THE ROUTER TYPE TABLE

- ✓ Various table sizes
- ✓ Full sheet nesting
- ✓ 4 working areas
- ✓ Rear, lateral and central reference stops
- ✓ Working grid routed on the machine for maximum precision
- ✓ Elevated vacuum cups for horizontal machining
- ✓ Panel expulsion devices

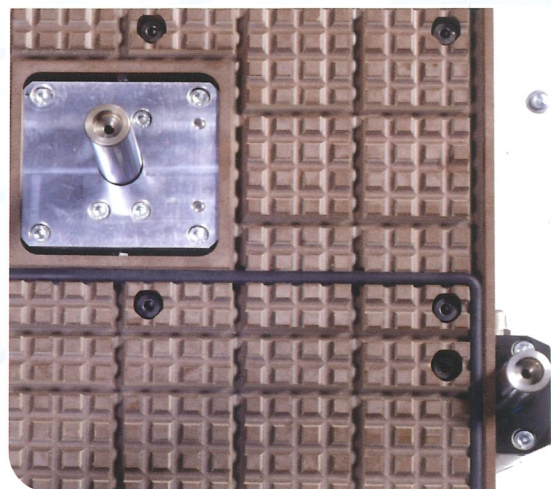

- Battute di riferimento
- Reference stops



- Pompa soffiante
- High flow vacuum pump



- Pompa del vuoto
- Vacuum pump





- Esempio di lavorazione nesting
- Example of nesting

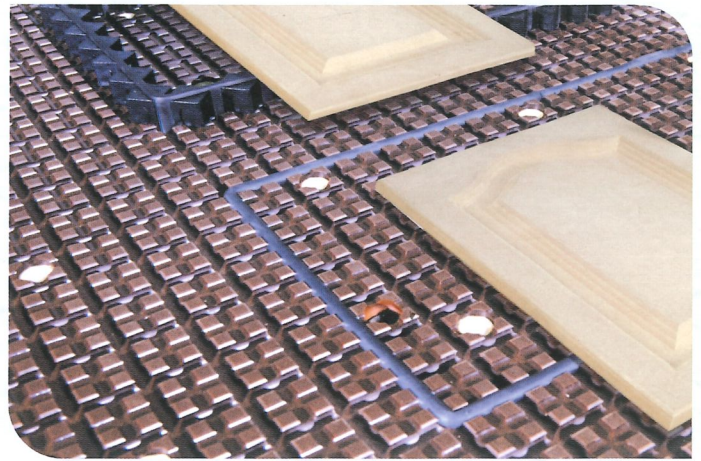

- Guarnizioni per selezione vuoto
- Gaskets for selecting vacuum area

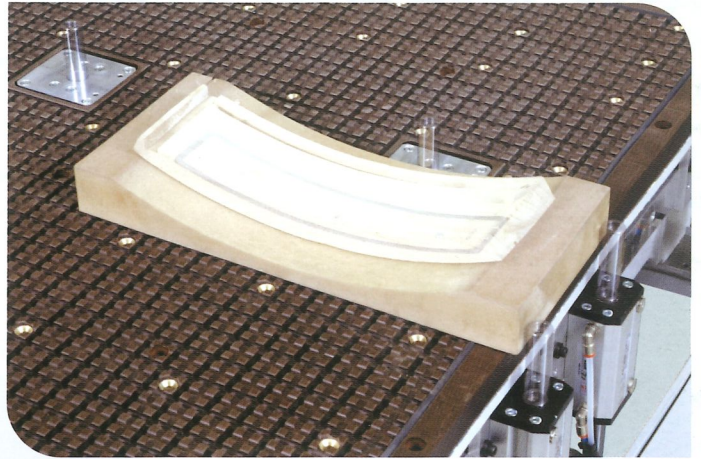

- Controsagoma per pezzi curvi
- Jig locking for curved parts

- Esempi di ventose per piano pantografo
- Examples of vacuum cups for router table

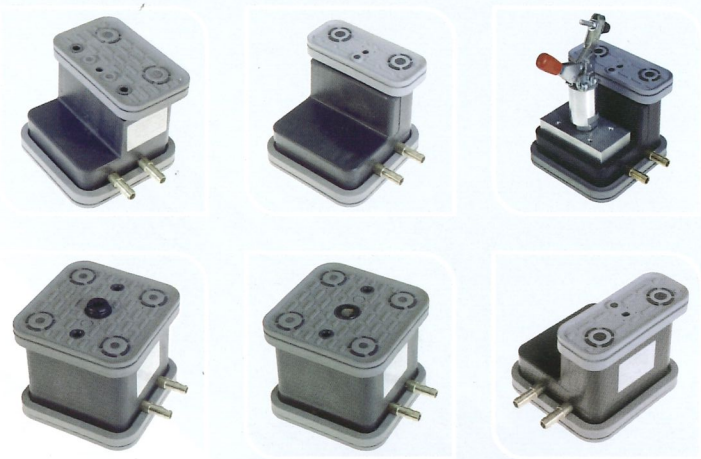

- Ventose rialzate
- Elevated vacuum cups

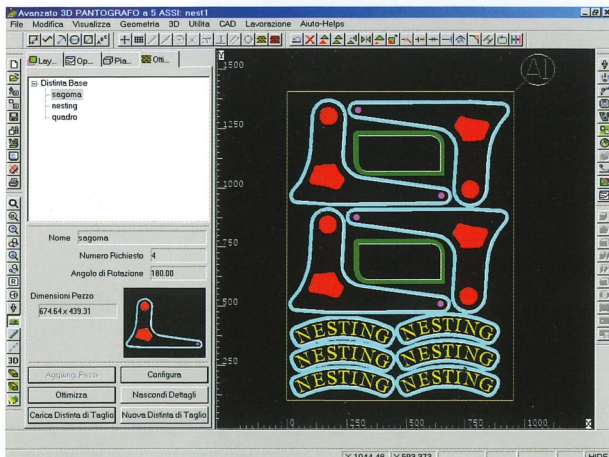

- Software per nesting
- Software for nesting



- Fissaggio pezzo su pannello martire
- Panel held on spoilboard



# FRESATURA E FORATURA

Potenza e precisione

- ✓ Varie soluzioni di elettromandrini e testate a forare disponibili
- ✓ Composizione testata specifica per ogni cliente

# ROUTING & DRILLING TECHNOLOGY

Power & precision

- ✓ Various options for electrospindles and boring heads
- ✓ Working head composition according to customers' requirements

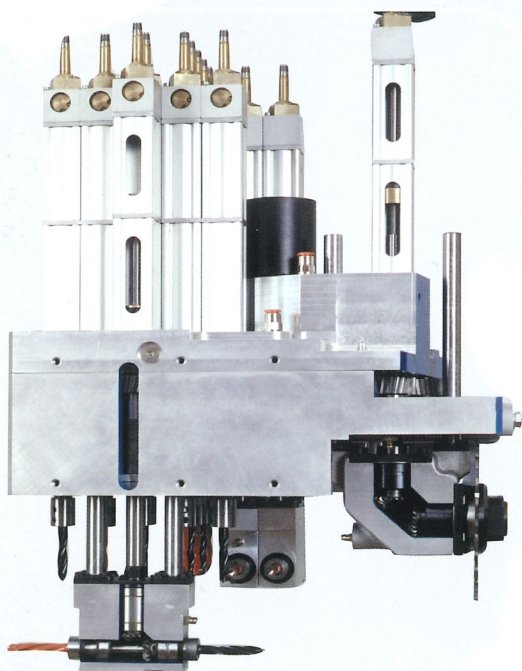
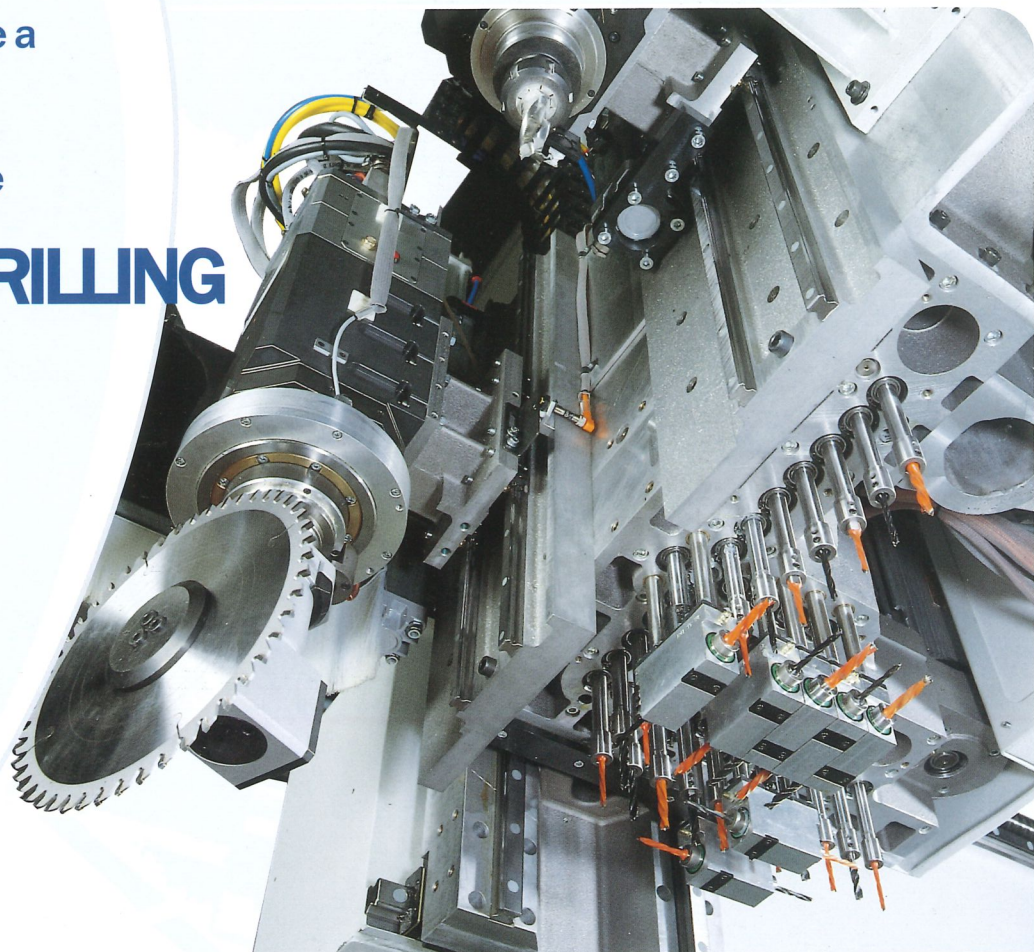

- Spaccato di testa a forare
- Section of the drilling head

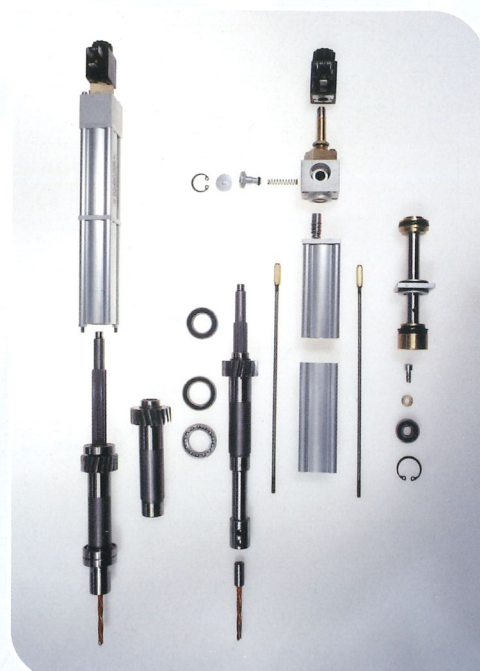

- Particolari del mandrino di foratura
- Detail of a drilling spindle



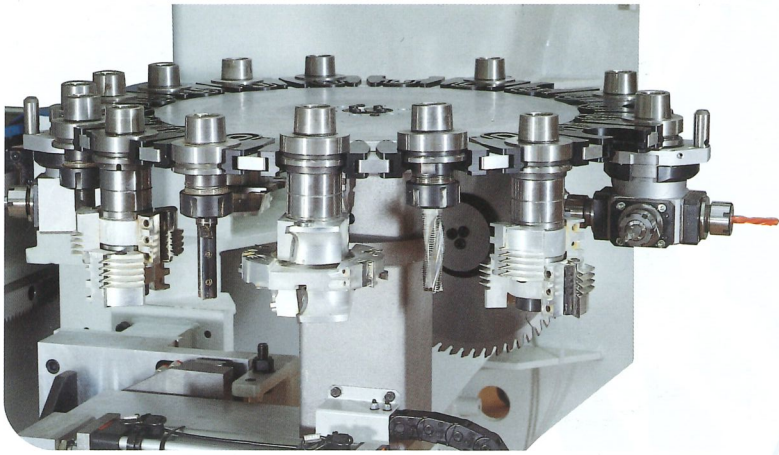

- Magazzino rotativo a bordo trave
- Post mounted rotary tool changer

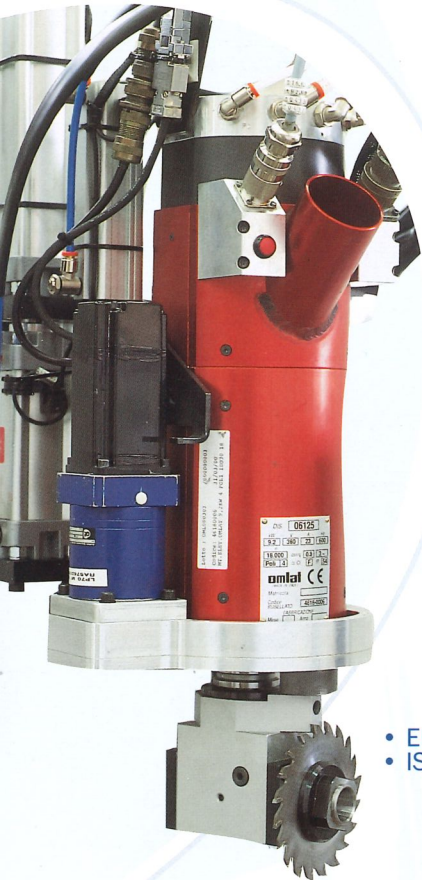

- Elettromandrino ISO 30
- ISO 30 electrospindle

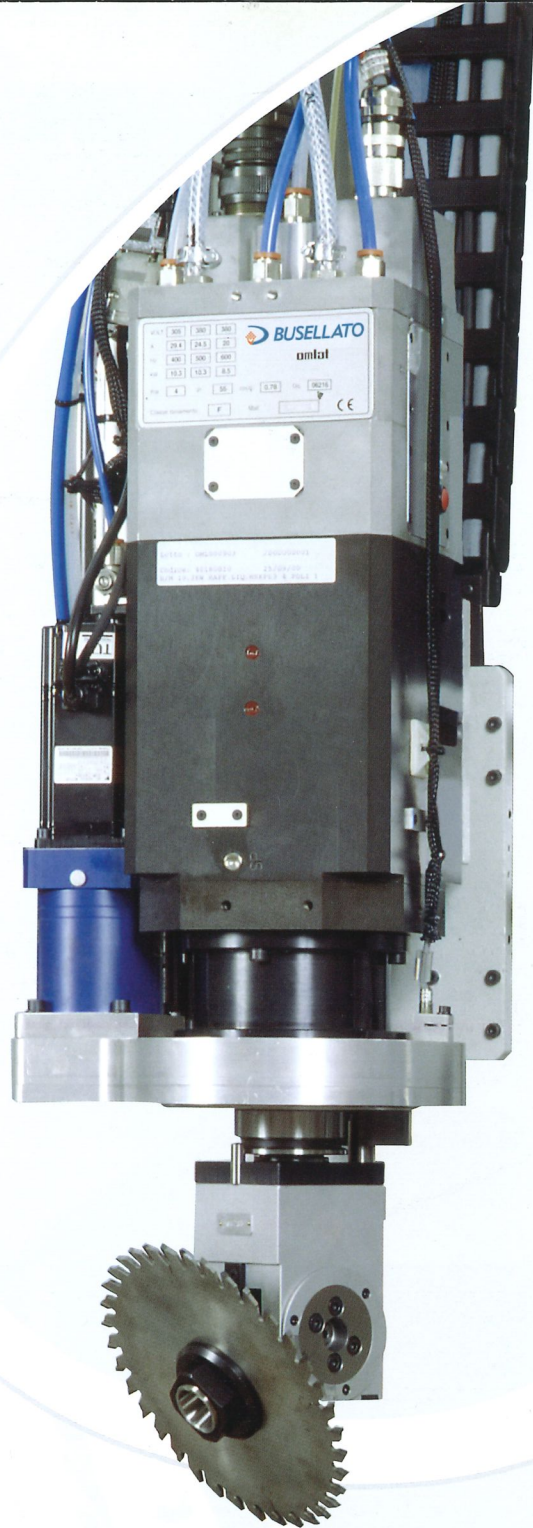

Elettromandrino HSK F63 refrigerato a liquido  
 HSK F63 electrospindle, liquid cooled

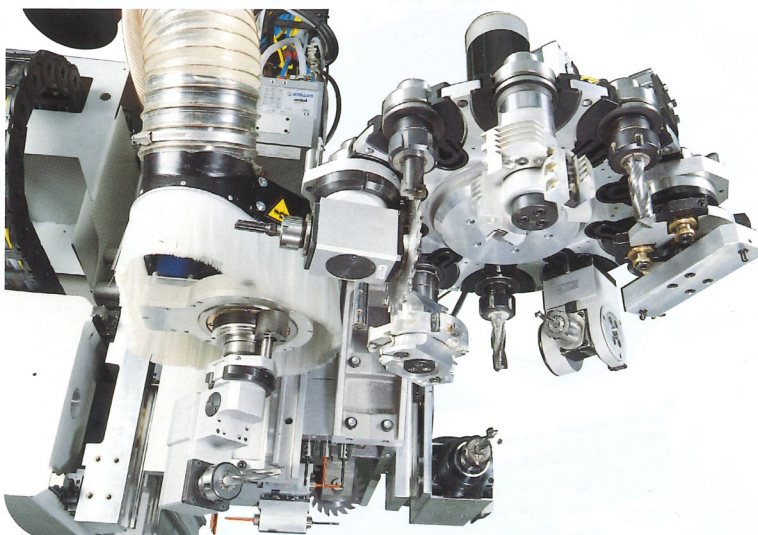

- Magazzino rotativo a bordo testa
- Head mounted rotary tool changer



- Gruppo refrigeratore per motori HSK F63
- Cooling system for HSK F63 electrospindles





- Testina inclinabile fresa/lama diam. lama 180 mm, lunghezza utile utensile 60 mm - ERG 25
- Aggregate for routing/sawing, adjustable 0 - 90° blade diam. 180 mm, useful tool length 60 mm - ERG 25



- Testina fresa/lama a 2 uscite orizzontali diam. lama 140 mm, lunghezza utile utensile 85 mm - ERG 25
- 2 outlet aggregate for horizontal routing/sawing blade diam. 140 mm, useful tool length 85 mm - ERG 25



- Testina fresa/lama a 2 uscite orizzontali diam. lama 220 mm lunghezza utile utensile 70 mm - ERG 32
- 2 outlet aggregate for horizontal routing/sawing blade diam. 220 mm useful tool length 70 mm - ERG 32



- Testina di fresatura/foratura a 4 uscite orizzontali lunghezza utile utensile 80 mm ERG 25
- 4 outlet aggregate for routing/boring useful tool length 80 mm - ERG 25



- Testina per lavorazioni orizzontali lunghezza utile utensile 110 mm ERG 32
- Cam box horizontal aggregate useful tool length 110 mm ERG 32



- Testina di fresatura con tastatore ERG 32
- Routing aggregate with tracer ERG 32



- Testina di profilatura con copiatore laterale ERG 32
- Routing aggregate with lateral feeler ERG 32



- Testina per lavorazione per cerniere
- Aggregate for hinges



- Testina per lavorazione a 90°
- Corner notching aggregate



- Testina per lavorazioni inferiori lunghezza utile utensile 25 mm, diam. 12 mm
- Underside routing aggregate useful tool length 25 mm, diam. 12 mm

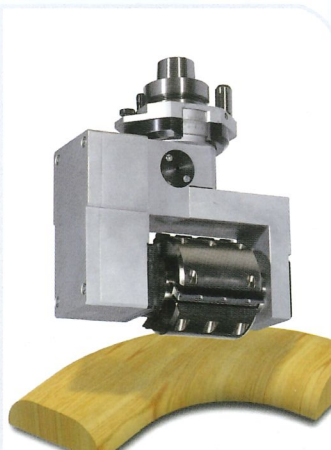

- Testina per profilatura/fresatura con controsupporto diam. fresa 100 mm, lunghezza fresa 90 mm
- Horizontal counterbalanced aggregate tool diam. 100 mm, tool length 90 mm



- Testina per lama diam. 300 mm
- Saw blade aggregate diam. 300 mm



# ELECTROSPINDLE HSK F63

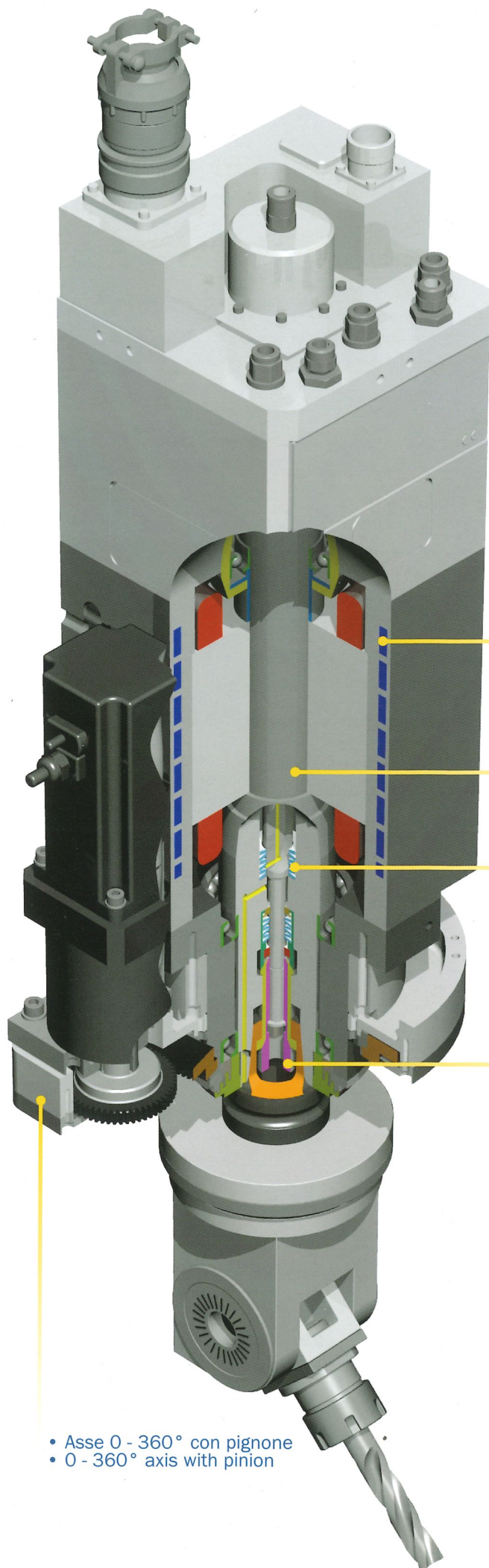

POTENZA ✓

PRECISIONE ✓

SICUREZZA ✓

POWER ✓

PRECISION ✓

SAFETY ✓

• Liquido di raffreddamento  
• Liquid cooling system

• Albero  
• Shaft

• Molle a tazza  
• Disk spring package

• Sistema di bloccaggio HSK  
• HSK clamping system

• Asse 0 - 360° con pignone  
• 0 - 360° axis with pinion



# PANNELLI - CABINETS



- Lavorazione antina MDF
- Machining of MDF door front

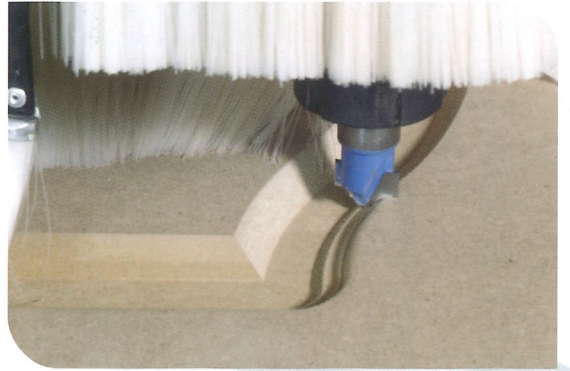

- Lavorazione di un fianco
- Machining of a cabinet side

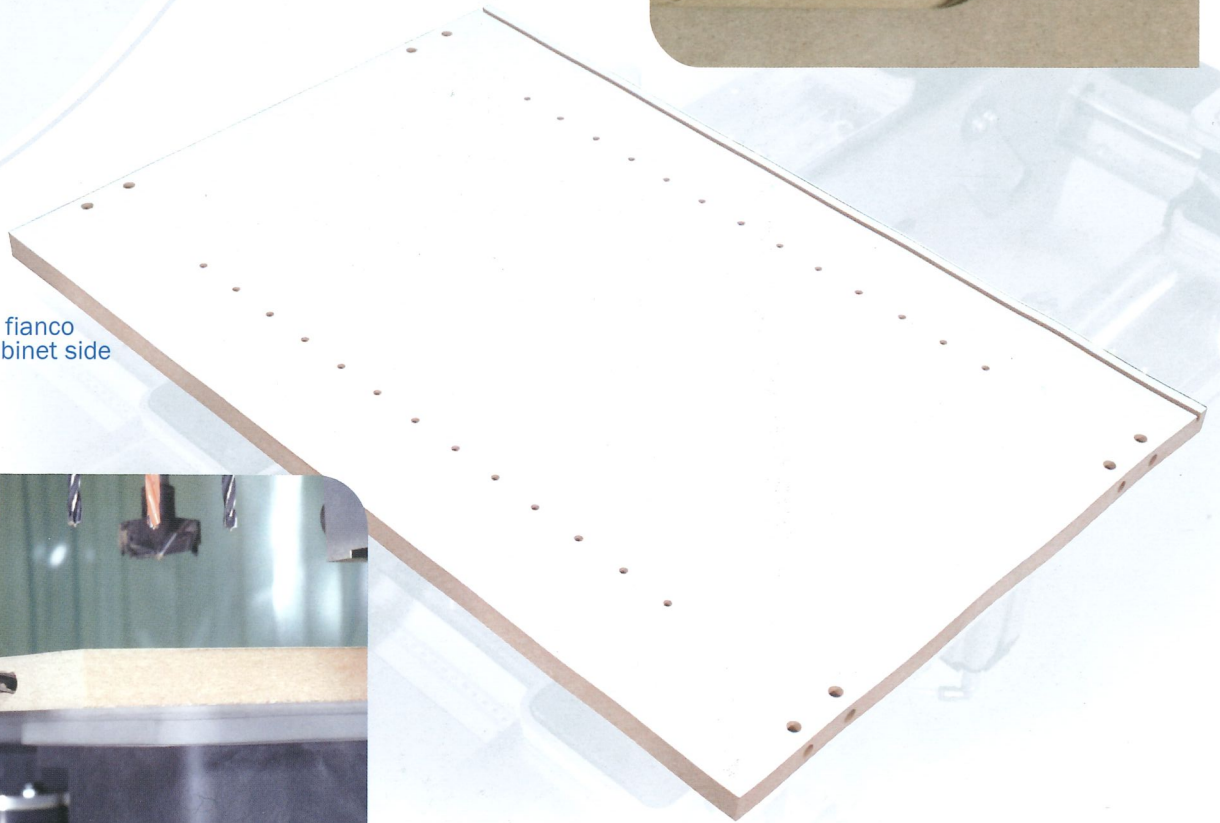

- Foratura orizzontale
- Horizontal drilling

- Foratura multipla verticale
- Vertical fitting



- Esecuzione lamata
- Grooving





# PORTE - DOORS

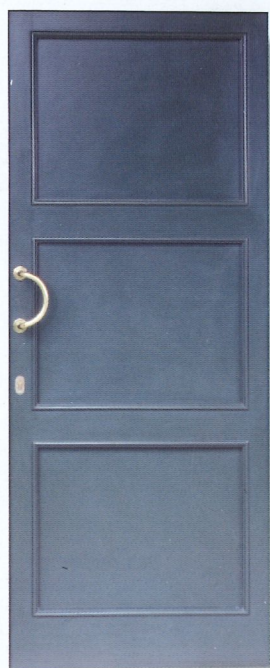

- Sfinestratura
- Internal routing

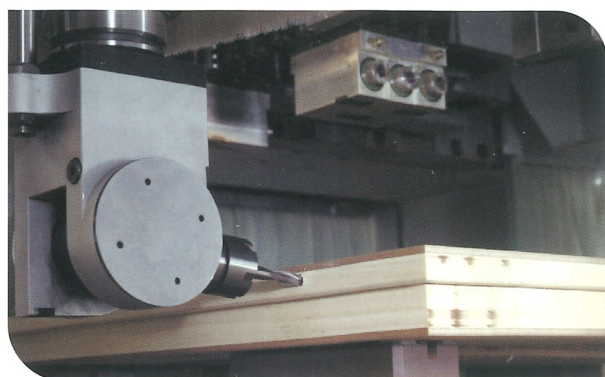

- Lavorazione per anuba
- Machining for door hinge



- Profilatura esterna
- External profiling

- Lavorazione fori per maniglia
- Machining for door handle

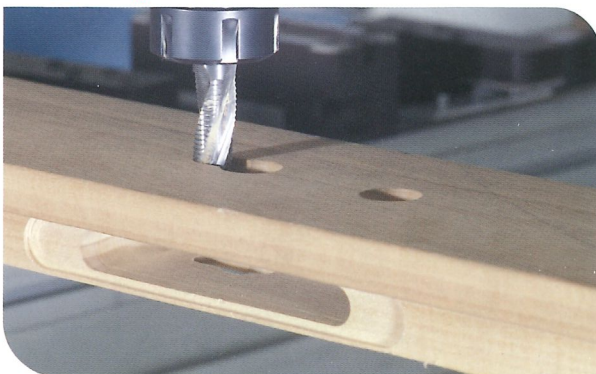
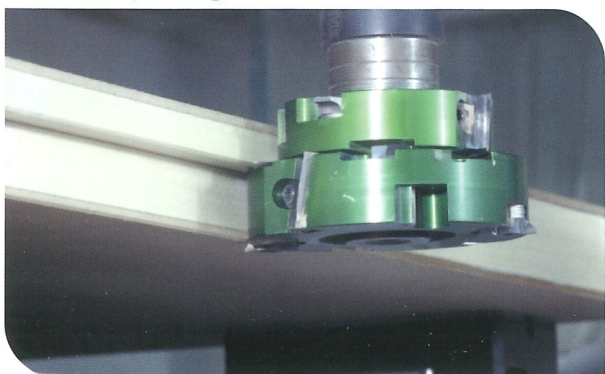



# PORTE - DOORS

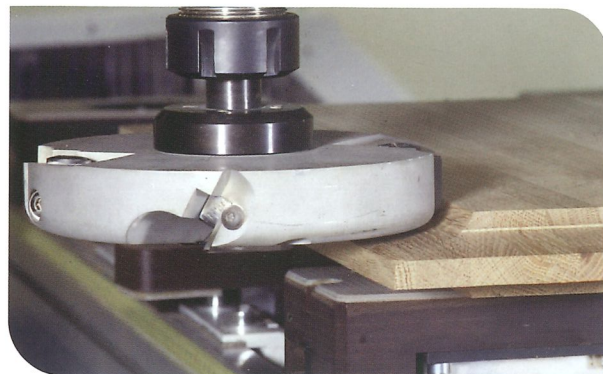

- Profilatura antina
- Center raised door panel profiling

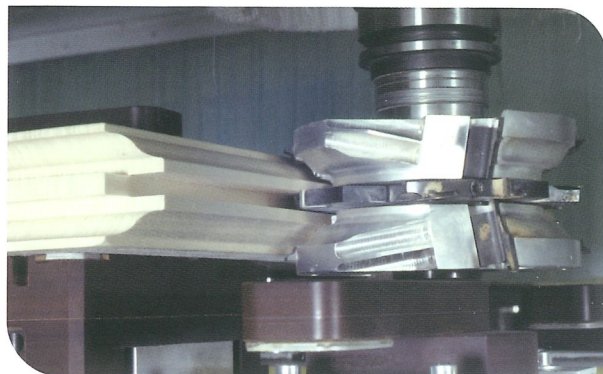

- Profilatura del montante
- Profiling and coping of stiles and rails

- Attrezzaggio banco con tutti gli elementi di una porta in massiccio
- Table set with all parts of a solid wood door

- Lavorazione scasso serratura
- Machining of door lock slot

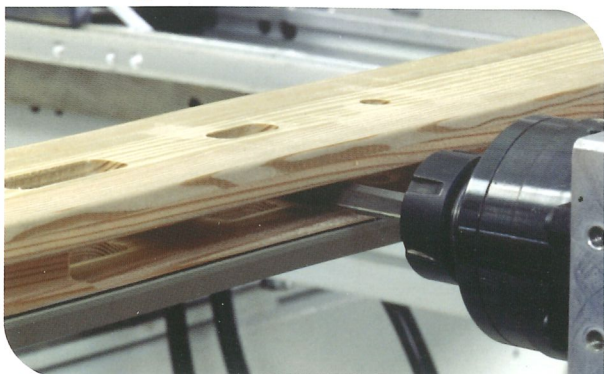



# ARCHI - ARCHES

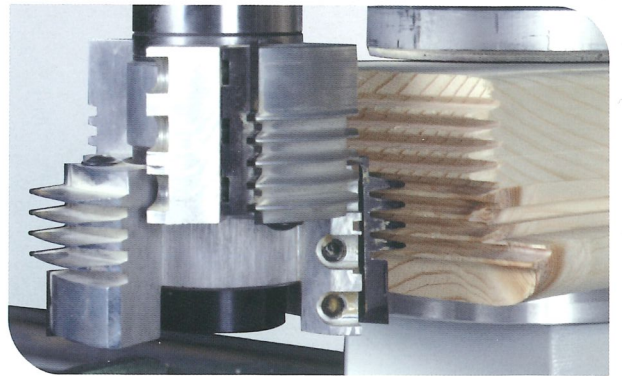
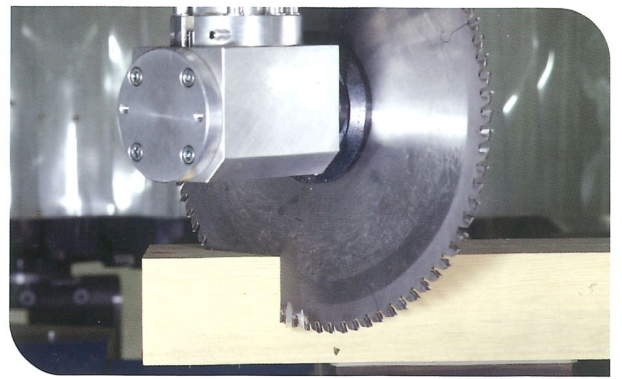

- Intestatura serramento
- Trimming

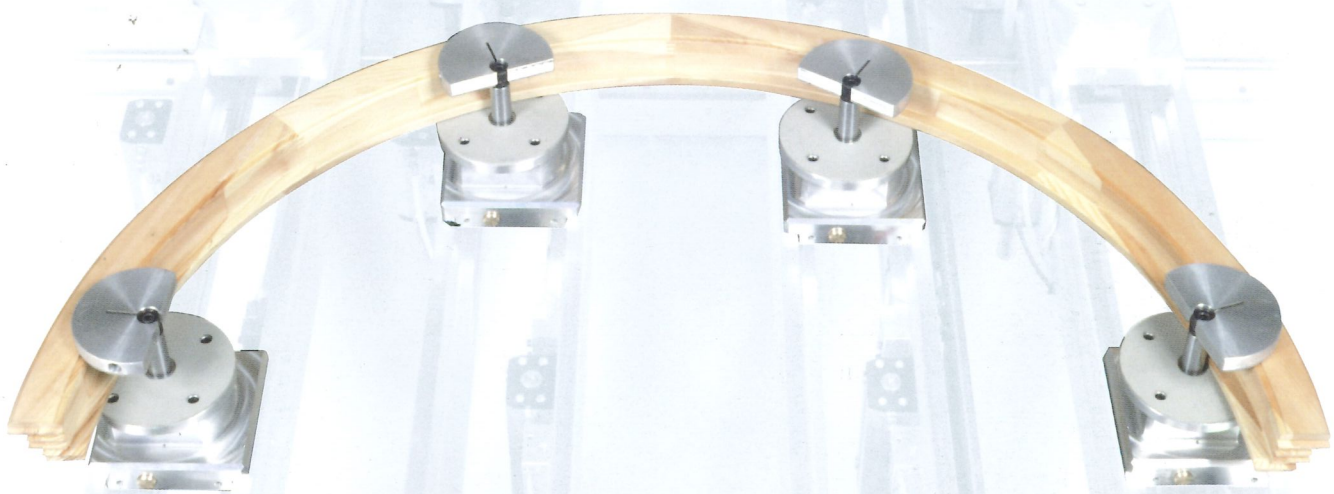

- Bloccaggio di un elemento di serramento ad arco
- Clamping of an arched window

- Profilatura interna ed esterna di serramenti
- Internal and external profiling of windows

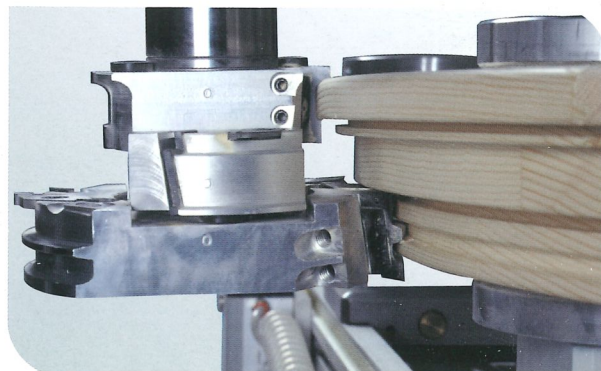
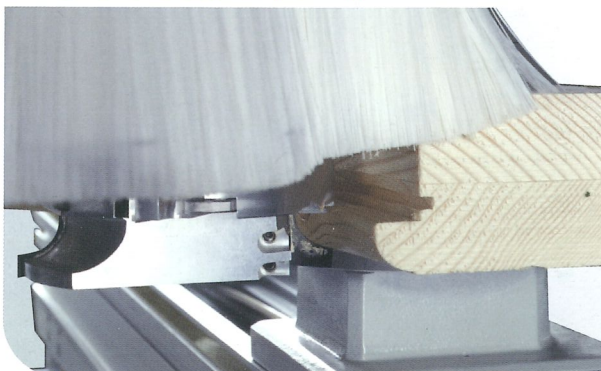



# GENESIS EVOLUTION

Programmare non è mai stato così facile

Programming has never been so easy

- Palette per selezione lavorazioni
- Machining bars

The screenshot displays the GENESIS EVOLUTION software interface. The main window shows a 3D model of a part with a circular feature. The interface includes a menu bar (File, Modifica, Visualizza, Inserisci, Strumenti, Opzioni, ?), a toolbar, and a parameter table for the selected feature.

Descrizione	Codice Iso
13 Fori su cerchio	G1010 P8020=200 P8021=H/2 R9=8 R11=50 R14
14 Ellisse y	G1026 P8020=80 P8021=H/2 R9=50 R10=100 R11...
15 Setup fresa (X,Y,Z)	G83 X80 Y199 Z=26 EGO EGO MSO D13 DW2 DW10...
16 A01 (centro) in piano XY	A01 X50 Y199 Z=26 EGO EVO la:70 Ja:199 F3
17 A01 (centro) in piano XY	A01 X50 Z352 Y205 Z=26 la:132 6394 Ja:199 016
18 A01 (centro) in piano XY	A01 X50 9526 Y211.5 Z=26 la:129 8149 Ja:199 2825
19 A01 (centro) in piano XY	A01 X52 1892 Y217.75 Z=26 la:124 5889 Ja:200 17...

Additional toolbars include 'Fresate', 'Fres. spe...', 'Speciali', 'macro', 'Fori', 'S0', 'S2', and 'Strum.'. A parameter table for 'Fori su cerchio' is visible, showing values for X Centro (200), Y Centro (H/50), Zp (-10), and other parameters.

- Palette strumenti CAD
- CAD instrument bars

Graphical programming on 6 faces ✓

Import of .dxf, .dwg files ✓

Free optimization ✓

3D Projections ✓

Full CAD/CAM ✓

Virtual faces ✓

Teleservice ✓

Reporting ✓

GENESIS EVOLUTION è stato concepito per fornire all'Utente finale uno strumento particolarmente potente ed intuitivo per la programmazione del centro di lavoro multifunzionale.

A questo scopo, GENESIS EVOLUTION mette a disposizione una serie di facilitazioni alla Programmazione, sia in ambito tecnologico che in ambito grafico, attraverso una serie di facilities geometriche e di strumenti di manipolazione dei disegni che consentono una più facile e sicura programmazione delle traiettorie di lavorazione.

GENESIS EVOLUTION è un programma sviluppato a 32 bit in modo conforme agli standard previsti dall'ambiente Windows.

GENESIS EVOLUTION has been designed in order to give the end user a powerful and user friendly instrument for programming the multifunctional working center.

With this aim, GENESIS EVOLUTION offers a series of special programming facilities, both technological and graphical, via a series of geometric facilities and instruments for manipulating drawings, that allow easier and a more secure programming of the machining trajectories.

GENESIS EVOLUTION is a program developed on 32 bit so as to conform with the implemented standard foreseen by the Windows environment.



# RAILPLAN

- Videata di Railplan
- Railplan screen

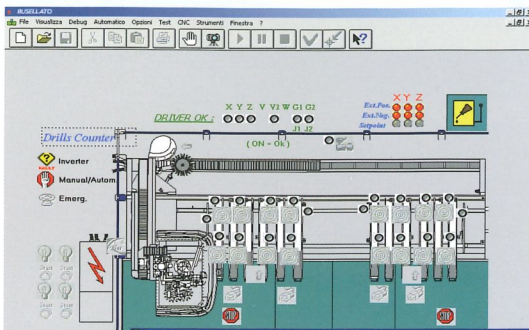
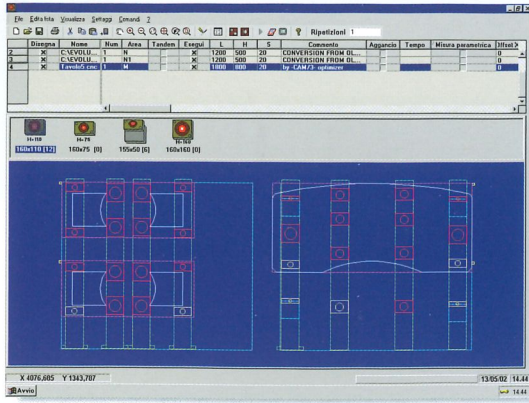

- Pagine con sinottici
- Examples of synoptics

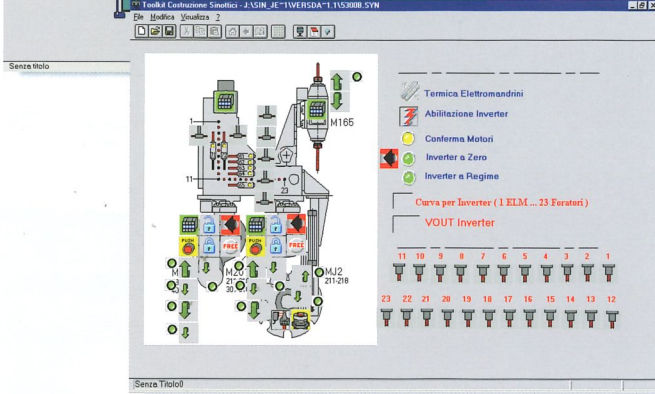

RAILPLAN è l'ambiente grafico previsto sul Controllo Numerico GENESIS EVOLUTION, per la Configurazione ed il Piazzamento interattivo delle traverse e ventose che costituiscono il banco di lavoro.

In questa fase l'Operatore può decidere come "popolare" le singole traverse sulla base del numero disponibile di ogni tipologia di ventose, potendo verificarne visivamente sulla rappresentazione grafica, gli spazi disponibili e gli eventuali vincoli.

Obiettivo finale è di consentire un posizionamento ottimale delle traverse / ventose, che da un lato garantisca la corretta tenuta dei pannelli, e dall'altro che non incorra in interferenze tra i dispositivi di bloccaggio e l'utensile in lavorazione, con particolare riguardo alla lavorazione passanti ed a quelle sui bordi laterali.

Al termine della sessione di programmazione, il sistema fornisce una serie di informazioni che consentono il piazzamento in automatico tramite il dispositivo da CN o in manuale tramite visualizzatori digitali e righe metriche.

RAILPLAN is the graphical environment foreseen by the GENESIS EVOLUTION Numerical Control, for the configuration and interactive placement of the panel supports and vacuum cups which make up the work bed.

In this phase, the operator can decide how to "populate" the individual panel supports depending on the number of vacuum cups of each type available, and can visually check the spaces available and any eventual restrictions on the graphical depiction.

The aim is to allow optimal positioning of the panel supports / vacuum cups, which guarantees both correct clamping of the panels and that there is no interference between the clamping devices and machining tools, with particular concern to the blank machinings and those on the lateral edges.

At the end of the programming session, the system supplies a series of information which allows automatic placing via the NC device or manual placing via digital displays and metric lines.

- Pagina di parametrica utensile
- Example of tool parametrics

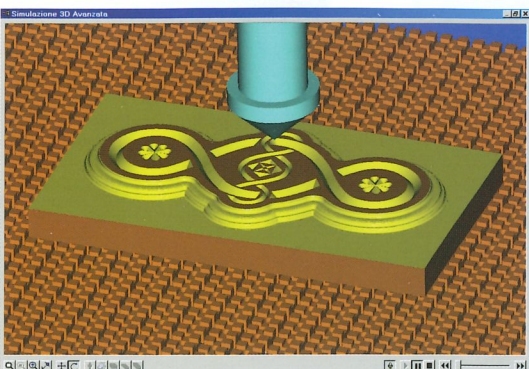
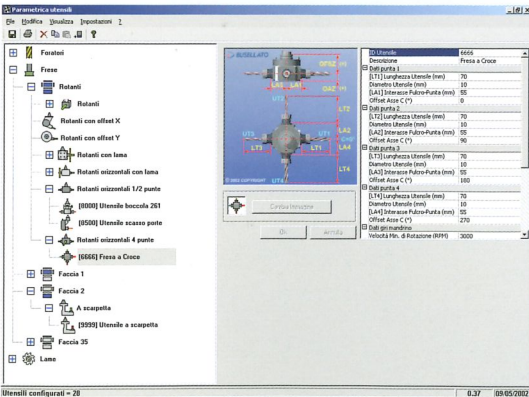

- Visualizzazione 3D della lavorazione
- 3D view of machining

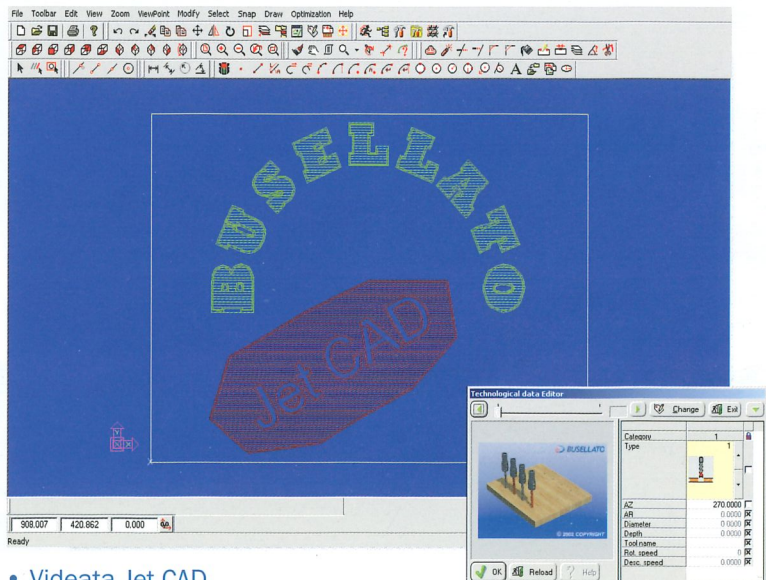

- Videata Jet CAD
- Jet CAD screen



# DATI TECNICI - TECHNICAL FEATURES

## JET 5

CAMPI DI LAVORO [mm]  
WORKING AREAS [mm]

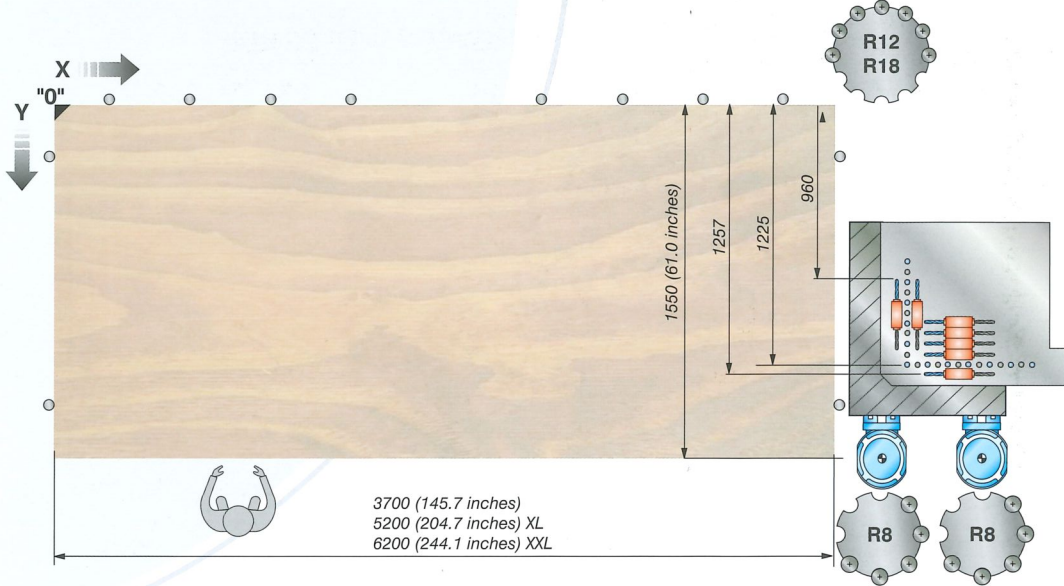

SPESORE UTILE LAVORABILE [mm]  
USEFUL WORKING THICKNESS [mm]

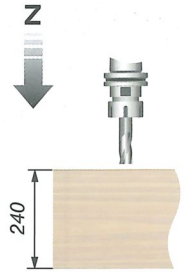

## JET 5 WF

CAMPI DI LAVORO [mm]  
WORKING AREAS [mm]

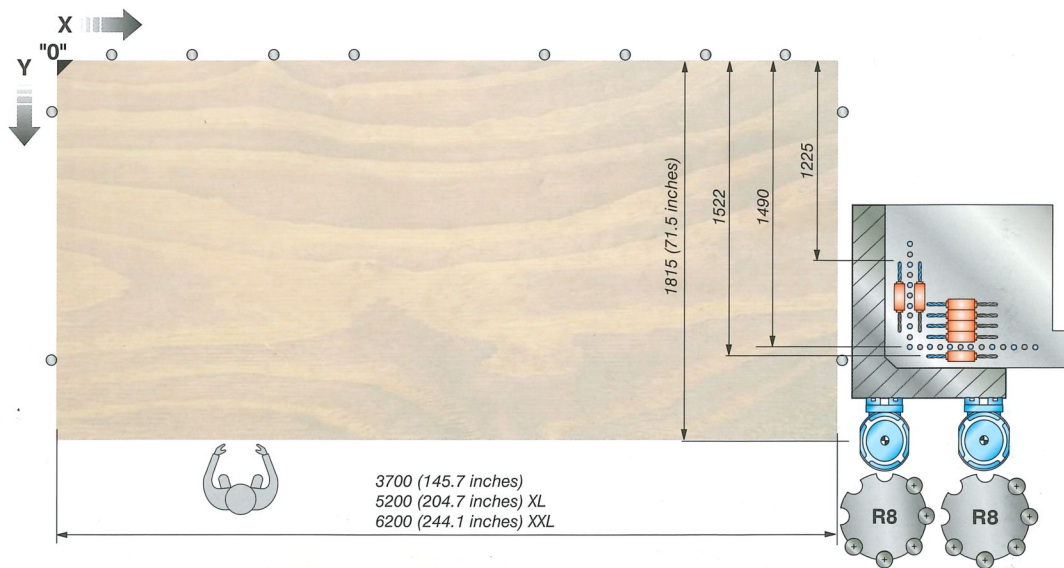

SPESORE UTILE LAVORABILE [mm]  
USEFUL WORKING THICKNESS [mm]

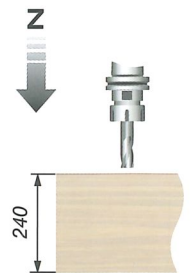



## CARATTERISTICHE TECNICHE TECHNICAL FEATURES

CORSE UTILI	USEFUL STROKE
ASSE X	X AXIS
ASSE Y	Y AXIS
ASSE Z	Z AXIS

TESTA A FORARE	BORING HEAD
Mandrini verticali asse X	X axis vertical spindles
Mandrini verticali asse Y	Y axis vertical spindles
Mandrini orizzontali asse X	X axis horizontal spindles
Mandrini orizzontali asse Y	Y axis horizontal spindles
Lama integrata	Integrated saw
Potenza motore	Motor power

POTENZA MAX ELETTROMANDRINO	MAX ELECTROSPINDLE POWER	kW
POTENZA INSTALLATA	POWER INSTALLED	kW
CAPACITÀ POMPA VUOTO	VACUUM PUMP CAPACITY	m <sup>3</sup> /h
PRESSIONE ARIA COMPRESSA	COMPRESSED AIR PRESSURE	bar
CONSUMO ARIA COMPRESSA	COMPRESSED AIR CONSUMPTION	l/1'
ATTACCO ARIA COMPRESSA	AIR CONNECTION COUPLING	Gas
DIAMETRO BOCCA DI ASPIRAZIONE	DUST EXTRACTION OUTLET	ø mm
CONSUMO ARIA ASPIRAZIONE	EXTRACTION AIR CONSUMPTION	m <sup>3</sup> /h
VELOCITÀ ARIA ASPIRAZIONE	EXTRACTION AIR SPEED	m/s
PESO MACCHINA	MACHINE WEIGHT	kg

JET 5	JET 5 XL	JET 5 XXL
-------	----------	-----------

mm	4130	5630	6630
mm	1890		
mm	370		

	TF 19+8	TF 23+14
Nr.	11	13
Nr.	8	10
Nr.	3+3	5+5
Nr.	1+1	2+2
ø mm	120	-
kW	3	3,6

kW	13,5		
kW	16 ÷ 29		
m <sup>3</sup> /h	100 ÷ 500		
bar	6		
l/1'	30		
Gas	1/2"		
ø mm	250		
m <sup>3</sup> /h	5300		
m/s	30		
kg	6000	7100	7300

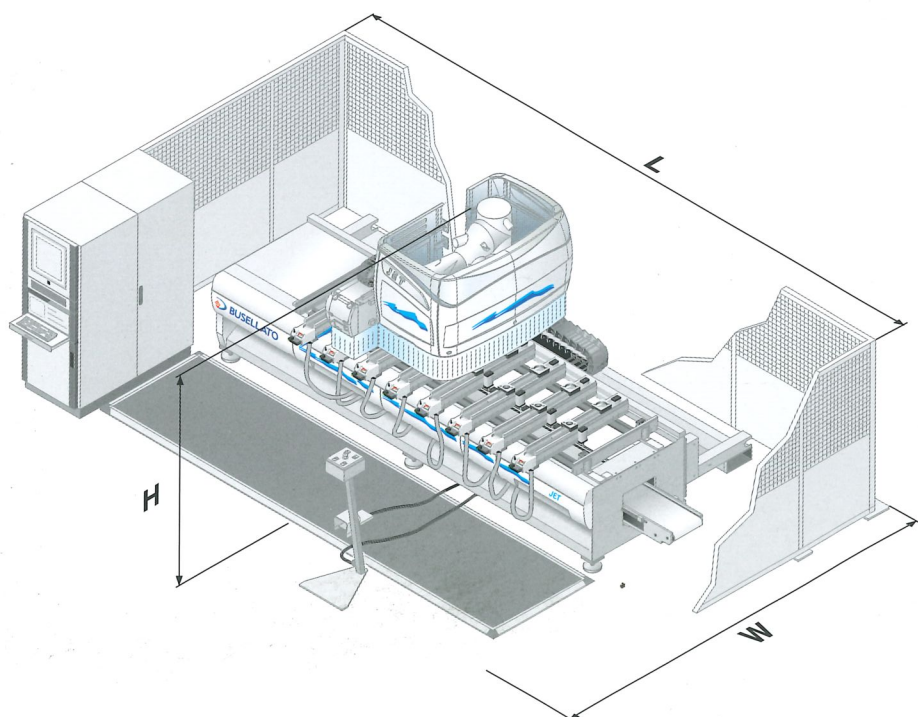

## DIMENSIONI DIMENSIONS

JET 5	XL	XXL
-------	----	-----

L	mm	7080	8560	9540
W	mm	4930		
H	mm	2810		





### **DELMAC S.p.A.**

Via della Fisica, 16/18  
36016 - THIENE - VI - ITALY  
Tel. +39 0445 313111 - Fax + 39 0445 313150

[www.delmac.it](http://www.delmac.it) - e-mail: [delmac@delmac.it](mailto:delmac@delmac.it)

### **CELASCHI S.p.A.**

Via F. e G. Celaschi, 25  
29020 - VIGOLZONE - PC - ITALY  
Tel. +39 0523 876811 - Fax +39 0523 876876-870425

[www.celaschi.com](http://www.celaschi.com) - e-mail: [info@celaschi.com](mailto:info@celaschi.com)

### **GABBIANI**

Via Roma, 101  
29027 - PODENZANO - PC - ITALY  
Tel. +39 0523 556011 - Fax + 39 0523 556201

[www.gabbiani.it](http://www.gabbiani.it) - e-mail: [delmac@gabbiani.it](mailto:delmac@gabbiani.it)

### **SAG Centro Tecnologico Italiano S.p.A.**

Viale del Lavoro, 30  
36016 - THIENE - VI - ITALY  
Tel. +39 0445 364220 - Fax + 39 0445 368588

e-mail: [delmac@sag.it](mailto:delmac@sag.it)

### **CPC S.r.l.**

Via Emilia, 19  
40056 - CRESPELLANO - BO - ITALY  
Tel. +39 051 732717 - Fax +39 051 731488

[www.cpcmac.com](http://www.cpcmac.com) - e-mail: [cpc@cpcmac.com](mailto:cpc@cpcmac.com)

### **DMG Delmac Machinery Group U.S.A.**

4322 Piedmont Parkway  
GREENSBORO, NC 27410  
Tel. + 336 8541211 - Fax + 336 8540811

[www.delmac.com](http://www.delmac.com) - e-mail: [sales@delmac.com](mailto:sales@delmac.com)



### **BUSELLATO S.p.A.**

Via Thiene, 104  
36013 - PIOVENE ROCCHETTE - VI - ITALY  
Tel. +39.0445.690000 - Fax +39.0445.652400  
[www.busellato.com](http://www.busellato.com) - e-mail: [delmac@busellato.it](mailto:delmac@busellato.it)