

TRS-400 Log Splitting Rip Saw

A profitable performer for small log trimming
Quality features create great trimming value.

- Stock infeed port : 400mm (W) X 400 mm (T)
- Max. dia of cut : Ø 400 mm
- Min. dia of cut : Ø 75 mm
- Top & Bottom Saw drive motor :
25 HP X 2, 30 HP X 2

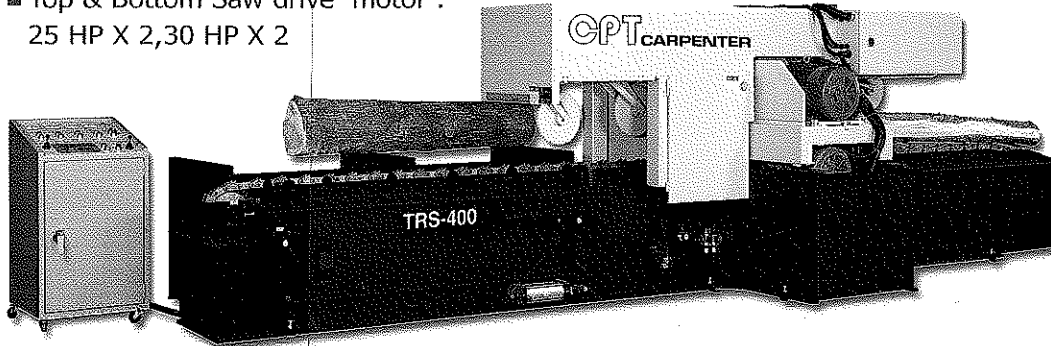
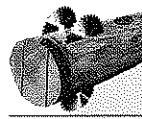

GBS-2503 Ho

Ideal for panel resaw and
Minimum thickness of cut
1 to 6 head band saw c
Various thicknesses of
simultaneously.

- Stock infeed port :
350 mm (14") (W) X 250 (10")
- Width of cut : 60 ~ 350 mm
- Thickness of cut : 5 ~ 250 mm
- Bandsaw drive motor :
20 HP (10 HP opt.)

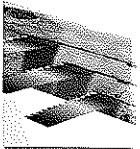

RS-365C / RS-366 / RS-366N / RS-466 / RS-466N

Integrating glue jointing application and trimming for your choice.
Take a measurement! Perfect straightness is not just a slogan.

- Max. cutting thickness :
85 mm (3.35), (100 mm, 4" opt.)
- Min. cutting length : 200 mm (8")
- Saw driver motor :
10 HP (15 HP opt.)

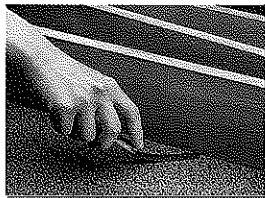

PERFECTLY STRAIGHT CUTTING
IS NOT JUST A SLOGAN

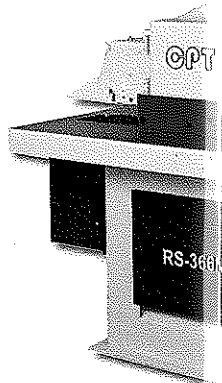
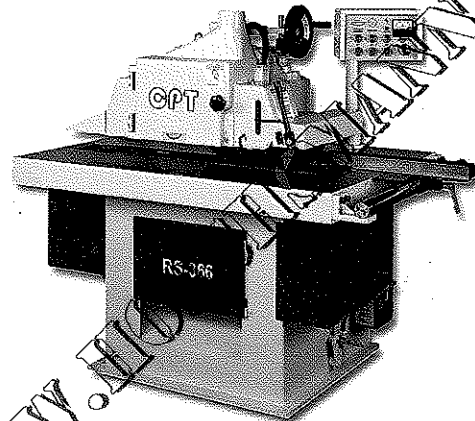
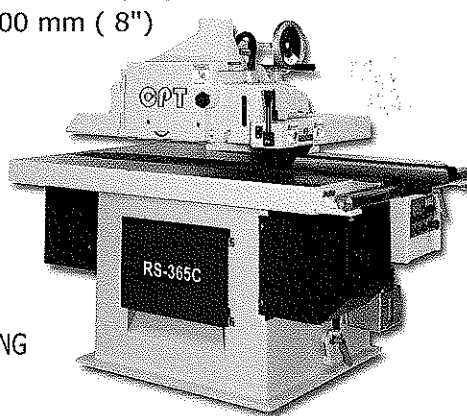

GRS-320 Multiple Rip saw

Ideal for furniture factories, material preparation
factories, and saw mill factories.

Great throat capacity :
780 mm from chain side
to arm.

- Cutting thickness :
10 ~ 130mm
- Max. cutting width : 320 mm
- Saw drive motor :
30 HP ~ 75 HP

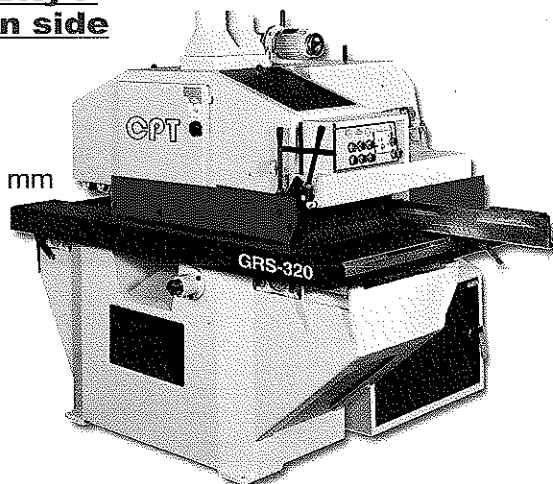
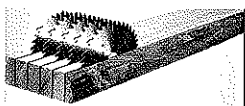

GRS-320H / GRS-320HAH

Heavy Duty. Max. Cutting Thickness

320H Max. Cutting Thickness 150
320HAH Max. Cutting Thickness 150

- Max. cutting width : 320 mm
- Saw drive motor :
75 HP ~ 100 HP



MATERIAL PREPARATION EQUIPMENT FOR SMALL LOGS.

Horizontal Band Resaw

oping. Fast size setting.
mm (3mm available upon request)
Instruction.
ut can be accomplished

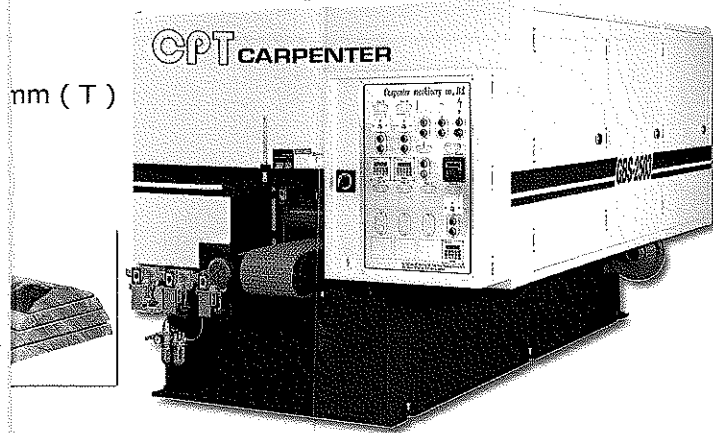

TRS-600 Movable Double Sawblade Trimming Rip Saw

Maximum width of cut up to 600mm. Excellent for pan.
Fast sawblade traverse. Distance between blades is n
Exclusive movable double sawblade configuration, v
The double sawblades can individually or simultane
modify large stock, or for material preparation.

- Cutting thickness : 10 ~ 165 mm
- Max. Infeed width : 750 mm

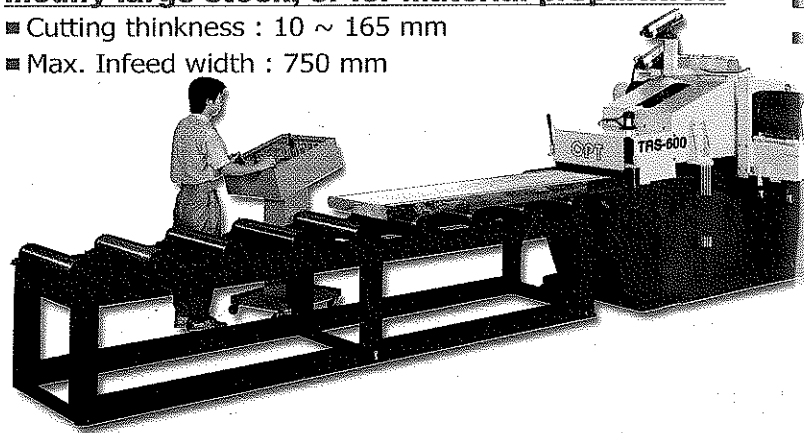

Straight Line Rip Saw Series

ht line rip saw designed to meet versatile applications.

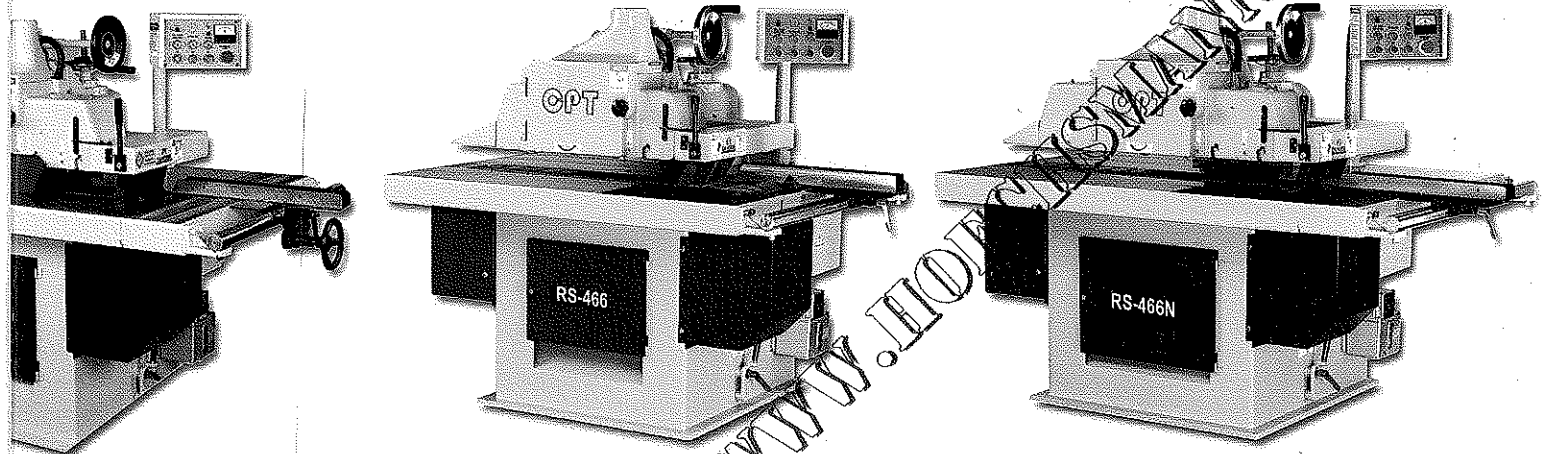

320HAH Multiple Rip saw

170mm.
5mm.
170mm.

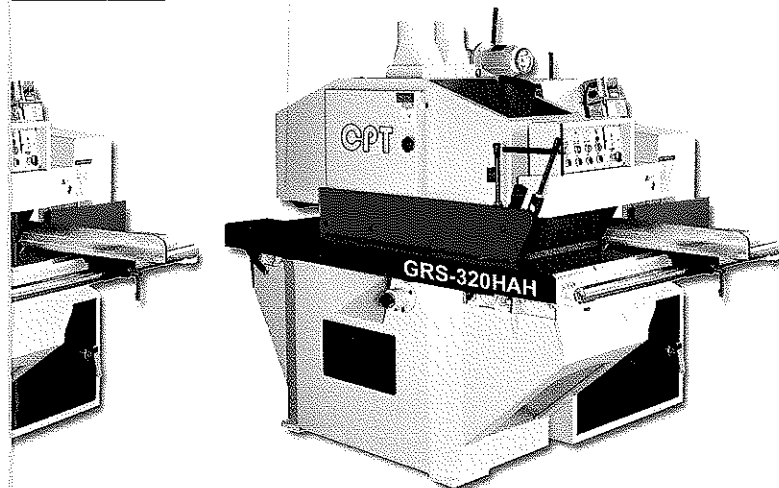

GRS-320S Short Multiple

Especially ideal for reclamation of short wo
A unique cutting capacity- As short as 8cm!
Turn your wood waste into usable material.
This machine is designed for easy
cutting of short stock, creating
value out of wood waste.
The unit can also cut long
stock.

- Max. cutting thickness / width :
130 / 320 mm
- Saw drive motor : 30 HP ~ 75 HP

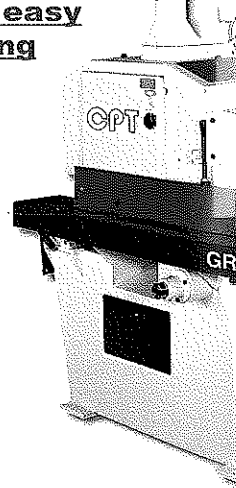
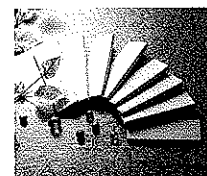

GRS-320B Adjustable Distance Double & Multiple Rip Saw

Variable width setting through blade positioning.
Your best choice for panel trimming.

The machine combines both trimming and multiple rip saw functions. Your profitable production partner for material trimming, modification and preparation.

- Max. cutting width / thickness (Trimming) :
320 / 65 mm, 300~200 / 75 mm,
200 ~ 130 / 105 mm

- Max. distance between saws :
30 ~ 320 mm (Trimming), 320 mm (Multi-saw)
- Min. length of cut : 700 mm (Trimming), 680 mm (Multi-saw)
- Saw drive motor : 30 HP ~ 75 HP

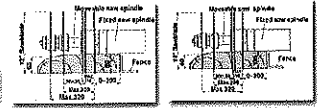
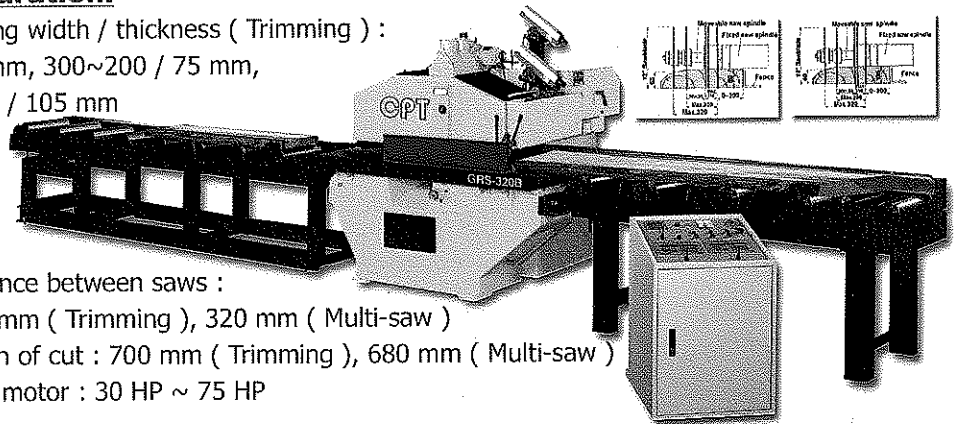

trimming.
emorized.
with perfect concentricity.
usly be used to trim or
Min. length of cut : 600 mm
Saw drive motor :
20 HP X 2 (30 HP X 2 opt.)

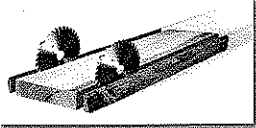
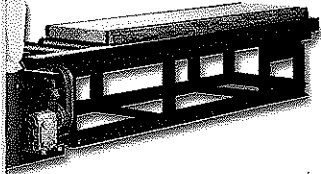

G-733 / 365-GM Auto Return Conveyor

The return conveyor is designed for saving labor requirement . Once the stock travels to the outfeed end of the machine, it will automatically return to the infeed end.

Roller Type

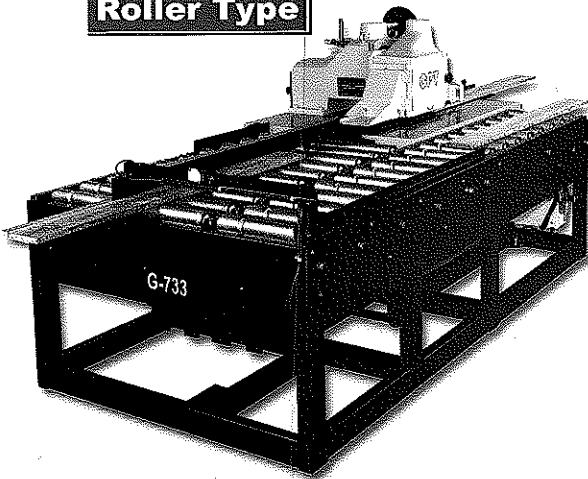

Belt Type

Economical Type

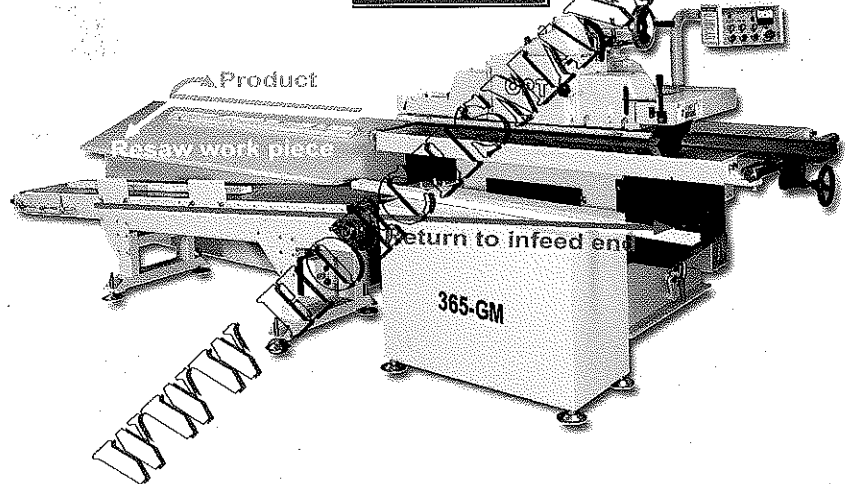

Rip Saw

d waste.

GRS-300 Multiple Rip Saw

Perfectly suited for cutting furniture parts and lumber cores. Minimum length 230mm.

Roller feeding design incorporated with bottom cutting for fast and stable ripping performance on core panels. Synchronized running for top and bottom feed. 10 rollers ensure smooth feeding effect.

- Max. cutting width :
300 mm
- Min. length of cut :
230 mm
- Cutting thickness :
10 ~ 125 mm
- Saw drive motor : 30 HP ~ 60 HP

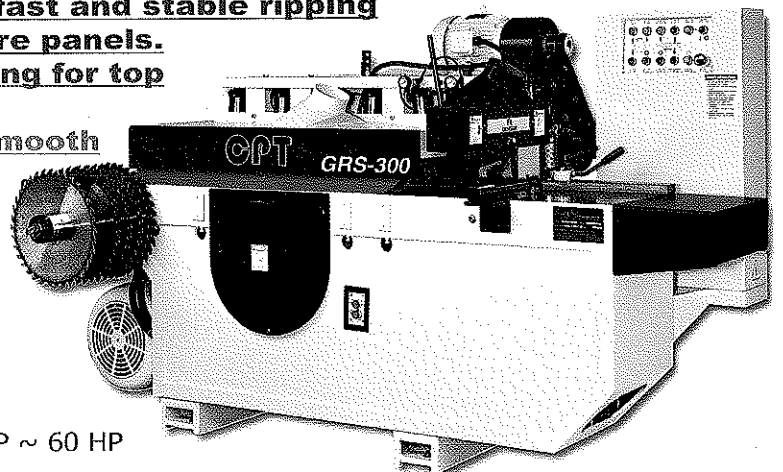
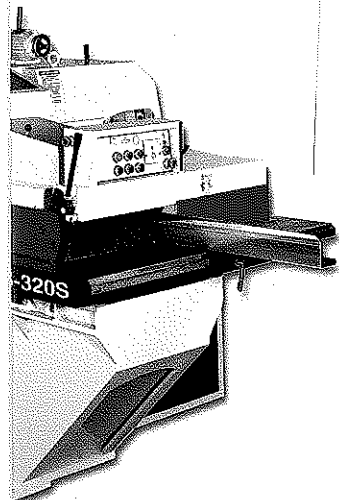
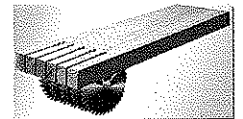

Double Surface planer engineered

CR-650 Double Surface Planer With Multiple Rip

Time and labor saving operation.

Perfectly suited for producing square wood in material preparation factories and sawmills.

Combines the functions of a planer and a multiple rip saw, saving time and labor.

- Max. width of planing : 650 mm
- Max. width of ripping : 600 mm
- Thickness of cut : 12 ~ 150 mm

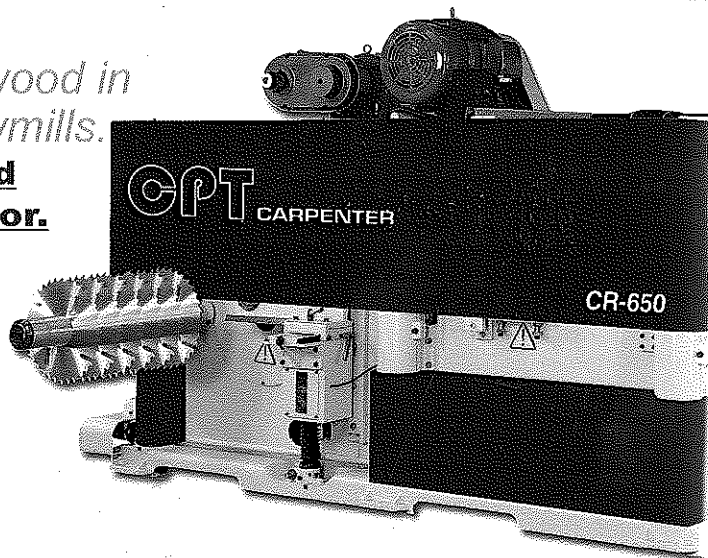
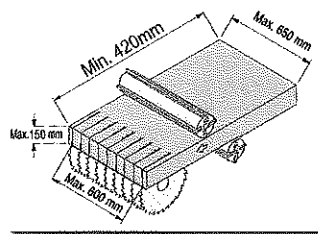

IT'S VERY WELL
MADE IN TAIWAN

CR-650DP Double Surface Planer

Heaviest cutting capacity, fastest cutterhead change speed. Premium fastest cutting model. Sp

Exclusive design of combination spiked conveyor mechanism and sectional feeding rollers.

Chain type; suitable for furniture and material preparation factories.

Fast planing speed --- 28 m/min

Superior planing --- Top and bottom 26 mm

- Max. width of planing : 650 mm
- Thickness of cut : 8 ~ 200 mm
- Min. length of planing : 398 mm

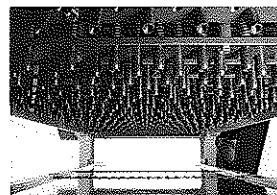

PRESSURE SPIKES FEEDING SYSTEM

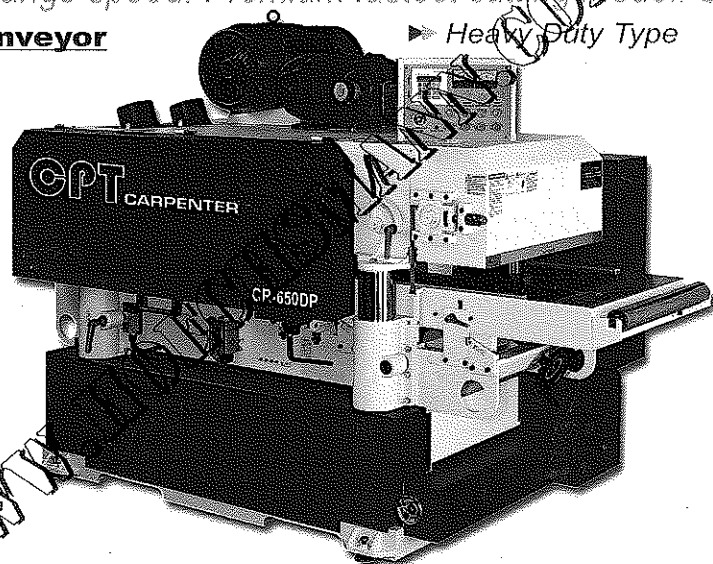

IT'S VERY WELL
MADE IN TAIWAN

SC-230 High Precision Sorting Cut Off Machine

A machine that dramatically upgrades speed and efficiency.

Fixed line cutting function. Cut to size function. Identical length setting function.

Provides various cutting modes for flexible cutting requirements.

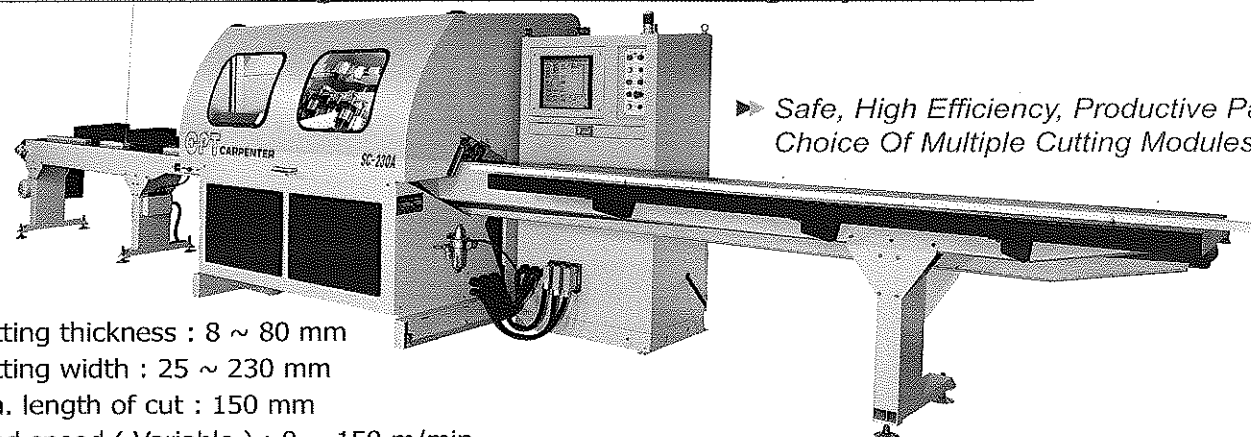

► Safe, High Efficiency, Productive Partner Choice Of Multiple Cutting Modules!

- Cutting thickness : 8 ~ 80 mm
- Cutting width : 25 ~ 230 mm
- Min. length of cut : 150 mm
- Feed speed (Variable) : 0 ~ 150 m/min

o meet your rigorous requirements.

Saw

OCR-400 / OCR-610 Double Surface Planer

A necessity in furniture factories.

Superior planing capability.
Chromium coated table surface.
Dovetail slideways design.

- Max. width of planing :
400 mm (16"), 610 mm (24")
- Thickness of cut : 10 ~ 200 mm

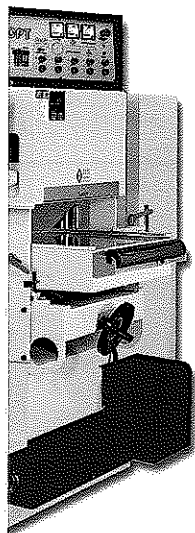

PRESSURE SPIKES FEEDING SYSTEM

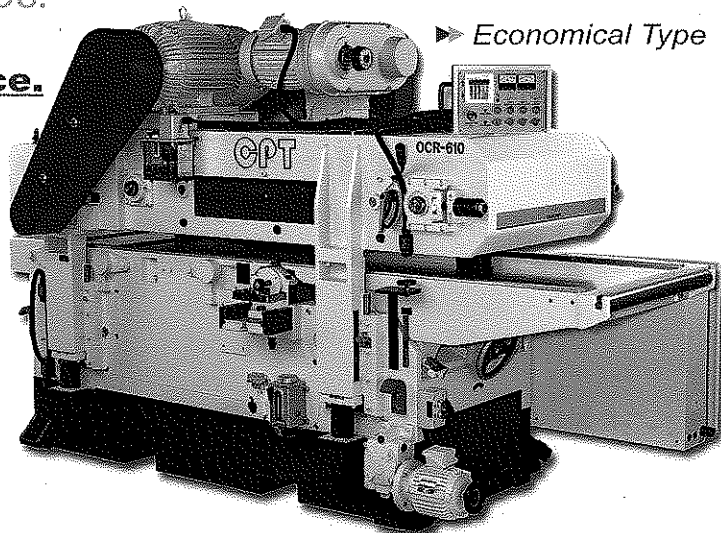

► Economical Type

CR-650D Double Surface Planer

► Heavy Duty Type

Specialized and outstanding front/rear pressure shoes and sectional

infeed roller design.

Powerful Sectional Roller Infeed Mechanism Ideal for Heavy, Wide, Long And Moist Wood.

Fast planing speed --- 36 m/min.

Superior planing --- Top and bottom 26 mm.

- Max. width of planing : 650 mm
- Thickness of cut : 8 ~ 200 mm
- Min. length of planing : 398 mm



IT'S VERY WELL
MADE IN TAIWAN

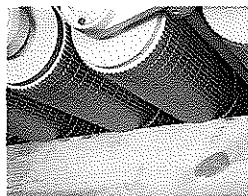

AIR LOADED SECTIONAL INFEED ROLLERS



Double Surface Planer
(For extra large workpiece)
CR-850DP / CR-850D (33")
CR-1100D (43")
CR-1300D (51")

T-48 / T-50 Air Frame Table

AGENT :

Easy to change sizes.

Suitable for assembling door, window, furniture and frame etc.

- Working sizes (L X W) :
T-48 : 2120 X 920 mm, T-50 : 2720 X 1220 mm
- Working Thickness:
10 ~ 98 mm
- Top cylinders : 3
Side cylinders : 2
(Custom pcs available)

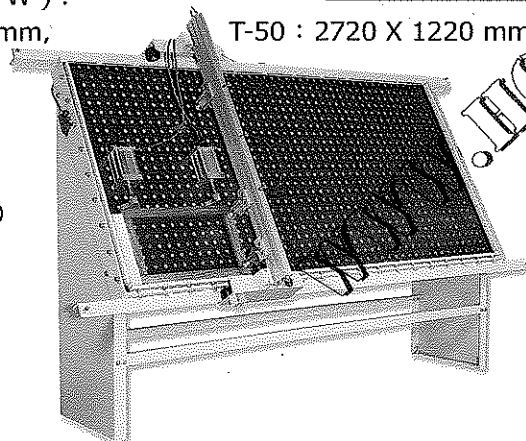
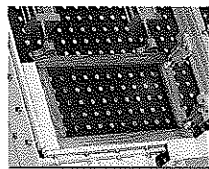

CPT®

CARPENTER MACHINERY CO.,LTD.

NO.32-5, LANE 247, TUNG CHOU RD., SHEN KANG HSIANG, TAICHUNG, TAIWAN 429 R.O.C

TEL:886-4-25287387~9

FAX:886-4-25262919

E-mail:carpente@ms35.hinet.net http://www.c-p-t.com

©All specification and design characteristics shown in this catalogue are subject to change without prior notice.