

# DJ-250

## FINGERJOINTING LINE FOR LONG STOCK

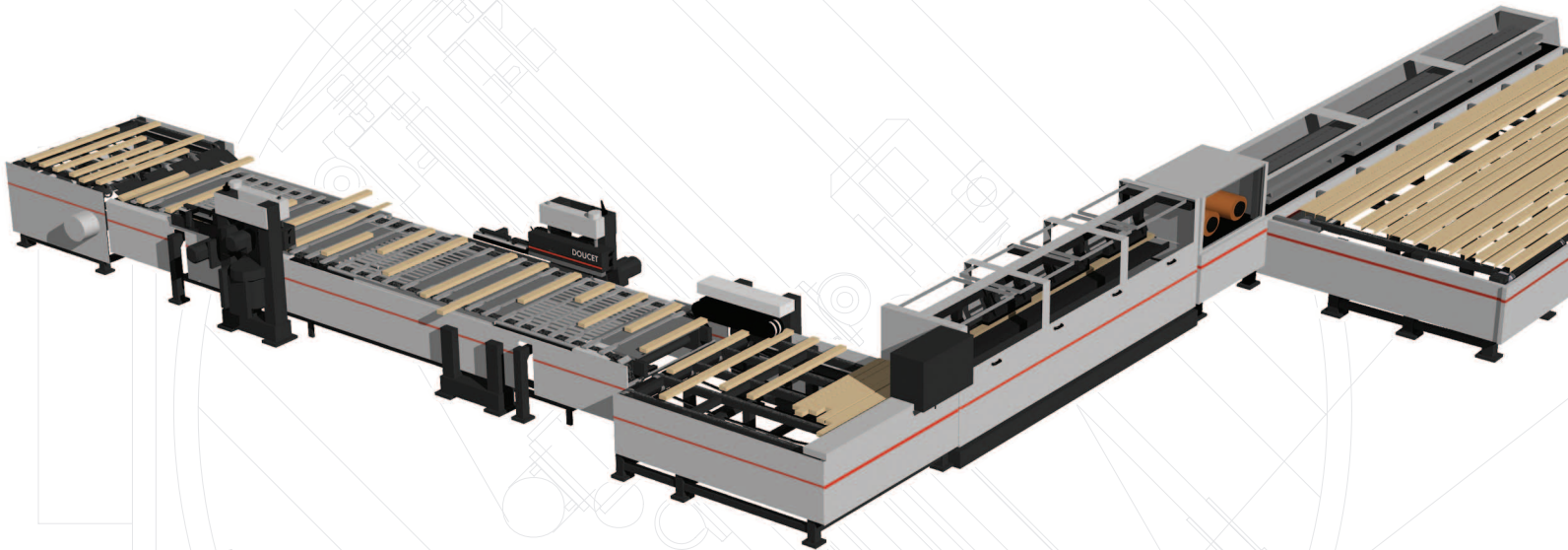

FOR STUDS, I-BEAM FLANGES AND  
EDGE LAMINATED / FINGERJOINTED  
SOLID WOOD SECTIONS

**DOUCET**  
**PROCESS ENGINEERING**  
*DIVISION*

**VALUE ADDED SOLUTIONS**

[www.hoechsmann.com](http://www.hoechsmann.com)

FOR A COMPLEX WOOD INDUSTRY

# DJ-250

## FINGERJOINTING LINE FOR LONG STOCK

A Double End Fingerjointer for long stock – 12" to 60", with traverse bars on 9" or 12" centers, a semi-automatic lug loader, a fully automatic corner and an automatic assembly press capable of producing up to 250 linear feet per minute of studs, flanges and other fingerjointed solid wood sections.

### THE DJ-250 AND LUG LOADER INCLUDE

- A Feed Conveyor 60 Inches Wide with Traverse Bars
- 5 HP Trim Saws
- 3 HP Scoring Saws
- 25 HP Cutterhead Spindles with Optional Variable Speed Drive
- High Precision Tenoner Chains
- In-Line Glue Applicator
- 20 HP Electric Motor with Variable Speed Drive

### THE AUTOMATIC PRESS INCLUDES

- Broad Radius OFFSET CORRECTOR
- Basic ASSEMBLY PRESS Capacity up to 24 Feet, Expandable up to 40 Feet
- Up to 10 PRESS CYCLES per Minute
- 14 Inch CROSS-CUT SAW on 5 HP Motor, 3400 RPM
- All Stainless Steel CONTACT SURFACES
- ALL FOUR FACES HELD While Pressing
- GULL WING TOP for Easy Cleaning and Maintenance

### THE FULLY AUTOMATIC CORNER INCLUDES

- Motorized Feed Wheels on Top and Bottom of Boards
- Automatic Traffic Control System

### THE HIGH SPEED ASSEMBLY TUNNEL FEATURES

- FEED SPEED up to 500 Feet per Minute, Adjustable by a Flow Control Valve
- Flat Chain BOTTOM FEED CONVEYOR
- Double Flat Chain LATERAL FEED to Prevent Offset
- Top HOLD-DOWN
- Unimpaired ACCESS and VISIBILITY
- Pneumatic QUICK RELEASE FEATURE

### PRODUCTION CAPACITY

#### DJ-250 FINGERJOINTING LINE

- |             |                             |
|-------------|-----------------------------|
| → LUG SPEED | Up to 100 Pieces per Minute |
| → OUTPUT    | Up to 250 Feet per Minute   |

### MATERIAL SPECIFICATIONS

#### DJ-250 FINGERJOINTING LINE

- |                   |                 |
|-------------------|-----------------|
| → BLOCK LENGTH    | 12 to 60 Inches |
| → FINISHED LENGTH | Up to 40 Feet   |

DISTRIBUTED BY:

**DOUCET**  
**PROCESS ENGINEERING**  
DIVISION

340, 6<sup>th</sup> Street, Daveluyville, Quebec, Canada G0Z 1C0  
Phone: (819) 367-2633 • Fax: (819) 367-2100  
Toll Free: 1-866-6RETURN (673-8876)  
Email: info@doucetinc.com • www.doucetinc.com

www.hoehlsmann.com