

C a l i b r a t i n g s a n d i n g m a c h i n e s

line
high
performances



NEW

EMC

UNDER-TOP

Top and bottom calibrating sanding line
Linea di calibratura e levigatura inferiore e superiore



Technical datas

Dati tecnici

Working width	mm	1100
Larghezza di lavoro		
Working thickness min-max	mm	3 / 160
Spessore di lavoro Min-max		
Abrasive belts dimensions	mm	1120 X 1900
Dimensioni nastri abrasivi		
Feeding and belts by means of inverter	m/min	2 / 22
Avanzamento e nastri comandati tramite inverter		
Roller diameters	mm	190 / 220
Diametro dei rulli		
CE European Safety Standards		
Normativa Europea di sicurezza CE		
High capacity vacuum system	kW	5,5
Sistema a depressione ad alta portata		
Total weight	kg	5500
Peso totale		

Standard technical specification

Caratteristiche tecniche standard

Constant pass line; fixed high from floor	mm	980
Macchina da linea e piano ad altezza costante		
Centralized control for full line; single push button start command		
Controllo centralizzato e unico pulsante per comando di avvio		
Touch screen technology; high resolution coloured display		
Video tastiera con tecnologia touch-screen a colori in alta definizione		
Pneumatic controlled infeed pressure bars		
Scarpette di pressione a controllo pneumatico		
Independent motors		
Motori indipendenti		
Feeding speed adjustable, controlled by inverter		
Avanzamento controllato e regolato tramite inverter		
Vacuum system device	kW	4 / 5,5
Impianto a depressione		
Sound proof		
Insonorizzazione		



Detail of internal groups
Particolare dei gruppi interni



Front view
Vista frontale



Electronic touch screen control
Controllore elettronico touch screen

Main options

Principali opzionali

Brushing units
Gruppi a spazzole
Automatic cleaning blowers
Soffiatori automatici pulizia nastri abrasivi
Reverse abrasive belts rotation
Inversione di rotazione nastri abrasivi

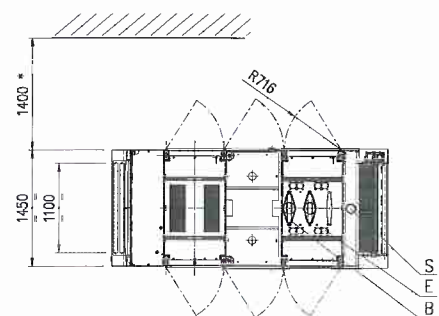
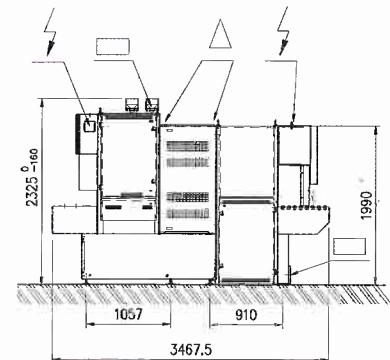
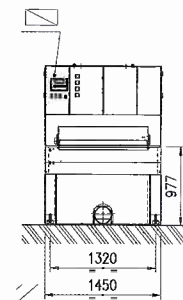
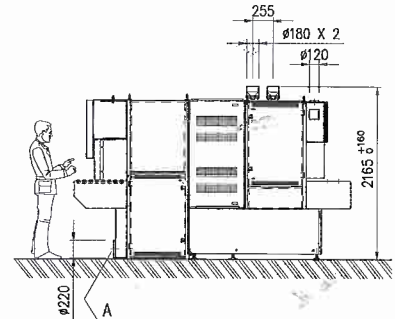

Via Brodolini, 23 - 40026 Imola (BO) Italy
Tel. +39 0542 688034 - Fax +39 0542 643959
e-mail: emc@emc-italia.it
www.emc-italia.it

