

FELDER®

D 951

Quality and precision

FELDER®



D 951

FELDER

D 951

Quality and precision



Solid wood



D 951

- » Surface planing width: 510 mm
- » Cutterblock: self-aligning planer knives;
Silent-Power® Spiral Knife Cutterblock (optional)
- » Max. depth of cut: 8 mm

This machine will provide you with a higher level of precision and quality than you would ever expect from a planer.

For decades, the Felder system with its disposable, reversible planing knives has proven its value. High-precision production and factory settings eliminate the need for tiresome adjustment work when changing planing knives or the purchase of expensive setting gauges.

Changing the planer knives is a piece of cake. In just a few minutes, the 4-knife cutterblock is ready for use with sharp new Felder planer knives.

... Your decision for Felder, a risk-free decision

- » The right machine for every budget
- » Complete reliability in professional use
- » Tailor made machine solutions
- » High quality cast iron machine table and aggregates
- » Innovative detail solutions derived from 65 years of experience - already included in the standard configuration
- » First class manufacturing and finishing standards
- » Intuitive application concepts
- » Modern, distinct design
- » Quality and precision from AUSTRIA
- » Powerful and efficient
- » Complete package: Comprehensive service support

The most important highlights at a glance



Silent-Power®

Exclusive for planer/thicknessers from the Felder Group. The Silent-Power® spiral blade cutterblock cuts noise levels during planing by well over half and provides a continuous pulling cut for tear-free planing patterns in any type of wood. With this revolutionary new development from you are obtaining all of the advantages of a spiral cutterblock at considerably lower operating, investment and adjustment costs. The benefits of the Silent-Power® spiral blade cutterblock at a glance:

- » Sensationally quiet, noise is reduced by 50%!
- » Blade life up to 20 times longer
- » Four highly precise cutting edges on each knife
- » Optimised chip extraction and reduced chip volume
- » Tear-free planing results



Variable infeed

Regardless of the type of wood and grain, the variable feed speed of between 4–16 m/min always guarantees a perfect planing result.



Power-Drive

The fully electrical "Power-Drive" planer table control offers the most precise adjustment and repeat accuracy. With a turn of the knob, you can quickly adjust the thickening height, then fine-adjust using the button. With the integrated LED-display, you can easily see the current actual value.



"Digi-Drive"

Enter the thickness required, press Start and the thickening bed adjusts exactly to the desired position. LED displays for the required and actual values. Additional functions: incremental adjustment, 4 programmable thickening table positions.

Details



Cutterblock housing

The solid cast iron cutterblock housing is built for heavy duty work. On request, rubberised outfeed rollers can be supplied. The pressure beams combined with the rubber or segmented infeed roller serves to machine simultaneously workpieces of differing width.



FELDER System cutterblock

The Felder system cutterblock has guaranteed perfect planing results for decades

- » Knife change in less than two minutes
- » Self-aligning knives are perfectly set each and every time
- » No resin buildup on the clamping screws
- » Extremely smooth operation due to the enclosed design
- » Maximum durability of the knives
- » Cost saving with cheaper knife costs

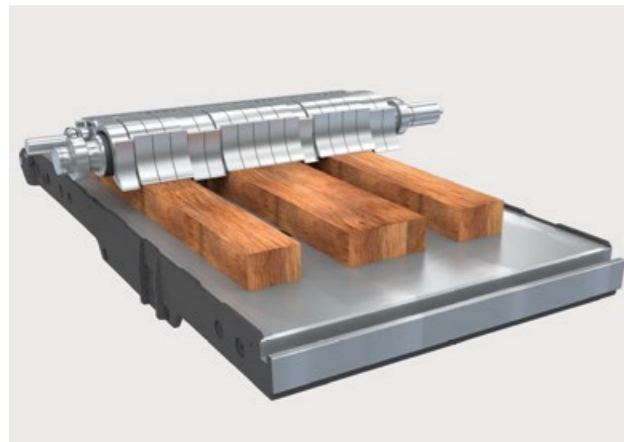

Spring loaded segmented pressure beam

A recommended option when planing with a small depth of cut, with very thin workpieces or workpieces with different thicknesses.

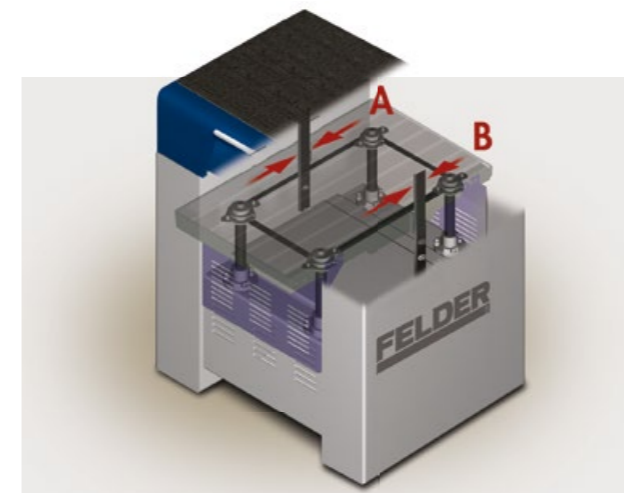

Trapezoidal threaded spindle

4 trapezoidal support spindles ensure utmost precision and high load bearing capacity. The thickening table slides precisely along the vertical guides in longitudinal direction (A + B). These longitudinal guides also absorb the feed pressure occurring during thickness planing in the direction of the outfeed.



Adjustable under table roller

Optional integrated adjustable bed rollers are available for processing workpieces with high resin or moisture content.

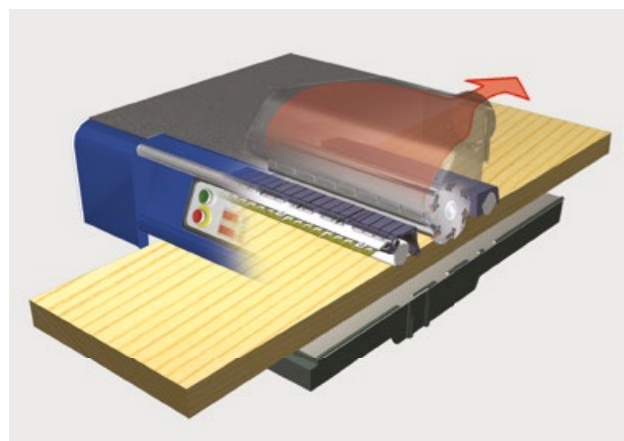

Dust extraction hood.

Heavy chip loads are no problem for the chip extraction hood due to its efficient design and large dimension. Two pressure bars prevent the fluttering of the workpiece, in particular thinner pieces when thickening.



Scissor lifting table

On request, the thickening table can be extended by 1,150 mm with a scissor lifting table.



Table extension

When thickness planing several workpieces at the same time, the 570 mm long table extension with outfeed workpiece roller assists in the removal of the finished workpieces.

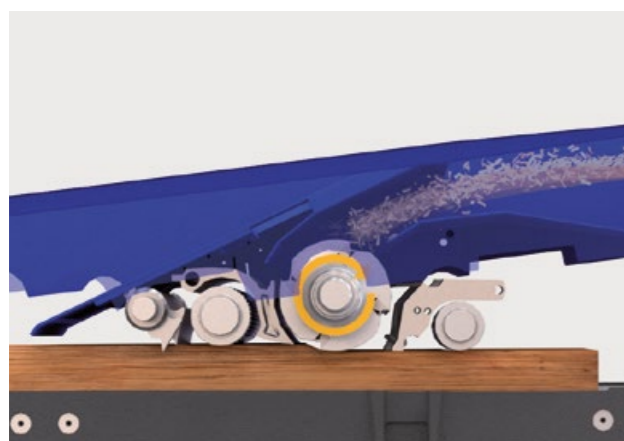

Perfect planing technology

Two pressure bars prevent the fluttering of the workpiece, in particular thinner pieces when thickening.



Workpiece roller on the infeed side

The workpiece roller is mounted on the infeed side. Only suitable for thicknessers with electrical thickening bed adjustment. Steel, powder coated.

Technical specifications

Electrics		D 951
001	3x 400 V motor voltage	S
002	3x 230 V motor voltage	W
004	50 Hz motor frequency	S
005	60 Hz motor frequency	W
006	5.5 PS (4.0 kW)	S
007	5.5 HP (4.0 kW)	O
008	10.0 PS (7.35 kW)	O
10	Star-delta start is necessary from 7.5 HP and 3x230V	O
12	Switch contact for the control of an extractor	O
13	Operating hour meter	O
Cutterblock		
39	4 knife Felder-system cutter-block	S
40	4 knife Standard cutter-block using traditional single sided planer knives	O
41	4 knife TERSA cutter-block	O
44	Silent-Power spiral cutterblock	O
-	Number of knives – Silent-Power spiral cutterblock	77
-	Cutterblock diameter in mm	120
Thicknesser and feed gears;		
50	Thicknessing width in mm	504
51	Digital display of the thicknessing height in mm;	S
52	Digital display of the thicknessing height in inches	O
53	Electrical height adjustment for thicknesser table ("Power-Drive" D1) (#55/60)	O
55	Electronic digital display for the thicknessing table adjustment (#53)	O
57	Variable speed 4–16 m/min	S
59	2 adjustable rollers under the thicknessing table, adjustment range 0–0.5 mm (#53)	O
60	Positioning control for thicknesser table height, dimensions can be preselected ("Digi-Drive D1") (# 53)	O
61	Rubberised infeed roller (#62)	O
62	Rubber outfeed roller	O
63	Spring loaded segmented pressure bar (recommended with Option 061)	O
-	Steel outfeed roller, micro-serrated	S
-	Min.-max. thicknessing height in mm	4–254
-	Steel infeed roller	S
-	Min. workpiece length in mm	250
-	Max. depth of cut (mm)	8

General		
-	Thicknesser extraction connection-Ø in mm	140
-	Weight kg (with standard configuration)	650
Important accessories		
211	Thicknesser table workpiece roller on the infeed side (#53)	O
223	IPPC palette	O
224	Table extension with workpiece roller for the thicknesser table (510 x 570 mm), limited to a maximum of 5 mm planing depth!	O
225	The scissor lifting table to be mounted on the thicknesser table	O
Transport		
221	Container transport preparation	O

Product range

Sliding Table Panel Saws

K 945 S K 740 S K 740 professional K 700 S K 700 professional K 700 K 540 S K 500 S K 500 professional K 500

Spindle Moulders

F 900 M F 900 Z F 700 M F 700 Z F 500 MS F 500 M

Saw-Shapers

KF 700 S professional KF 700 professional KF 700 KF 500 professional KF 500

Planers

AD 951 AD 941 AD 741 AD 531 A 951 L A 941 D 951 D 963

Combination machines

CF 741 S professional CF 741 professional CF 741 CF 531 professional CF 531

Bandsaws

FB 940 RS FB 740 RS FB 940 S/SW FB 740 S/SW FB 940/840 FB 740/640 FB 710 FB 610 FB 510

Dowel Boring Machine, Drilling Machine and Horizontal Mortiser

FD 29 professional FD 21 professional FD 250

Heated Veneer Presses

MVP 31.14 flex

Wide Belt Sanding Machines

FW 1102 perform FW 1102 classic FW 950 classic FW 850 classic

Brushing Machine

structura 60.02 structura 40.02

Belt and Edge Sanders

FS 722 FS 900 KF FS 900 K FS 700 K

Edgebanders

G 560 / G 580 classic G 500 EX G 480 G 380 G 360

G 330 G 263 G 220

ForKa 300 S eco

KV 925

Vertical panel saw

Extraction Units & Briquetting Presses

RL 350 RL 300 RL 250 RL 200 RL 160 RL 140 RL 125

FBP 50/60/70 AF 22-D200 AF 22 Mobil/Stand/Wandmontage AF 16 AF 14 AF 12

FELDER®

FELDER Quality and precision in a nutshell

Since 1956, a guarantee for perfect results with excellent ease of use and reliability in regular professional use. Woodworkers are always enthusiastic about the individual and solid solutions for small and mid-sized businesses.

FELDER GROUP

KR-Felder-Straße 1
A-6060 HALL in Tirol

🇬🇧 Tel. +44 1908 635000

www.felder.uk

[Contact](#)

🇮🇪 Tel. +353 906625756

www.felder.ie

[Contact](#)

🇮🇳 Tel. 1800 274 3040

www.felder.in

[Contact](#)

🌐 Tel. +43 5223 58500

www.felder.int

[Contact](#)