



Innovation in timber engineering

Speed Cut Machine SC-3

The fast automatic cutting machine for
timber construction companies

www.hundegger.de

 **Hundegger**

The high-performance cutting saw – fast, precise, flexible



More speed for timber processing

Tasks such as cutting simple timber elements quickly and precisely – without measurement, without marking, without setup and piece by piece production.

As options milling and drilling operations are possible. Exactly what the SC-3 has been developed for.

The heart of the machine is the flexible saw unit which can make cuts at any angle and inclination. Making difficult and dangerous jobs possible

For cross-sections from 20 x 50 mm to 160 x 450 mm or 200 x 450 mm.





Maximum flexibility with the modular system

Whether it is one-man company or an larger producer: The SC-3 is ideal for all timber construction companies. Every machine is precisely adapted to the individual needs of the customer – from a simple cutting machine to a large CNC processing centre.

The SC-3 has enormous potential even in its basic configuration level. The saw unit alone can perform a wide variety of different processing operations in addition to simply cutting materials to length. And if you need more: The modular design means that the standard machine can be extended at any time and equipped with additional units. Drilling, milling, slotting, marking, labelling – the SC-3 can do everything and quickly



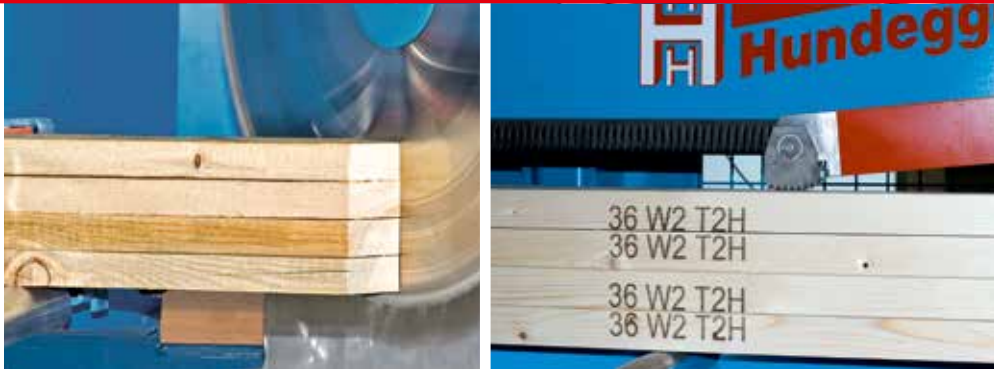

Secure your competitiveness

The fully automatic systems from Hundegger with their high precision and performance will increase your productivity and profitability of your timber construction company. The SC-3 was primarily developed for particularly fast and precise cutting operations as well as for many other processes required in timber construction.

Increasing productivity of your company means you increase your competitiveness: When it comes to cutting Trusses, Glulam sections or timber frame construction parts, the SC-3 is the fastest machine of its type.

Greater efficiency –
in series production and
one-off production



The HUNDEGGER system – unrivalled accuracy

Maximum speed, absolute precision

Two independently operating conveyor systems position the workpieces and ensure fast and precise timber handling. The advantage is a short throughput time without adjustment or retooling.

The SC-3 processes timber cross-sections of 20 x 40 mm to 200 x 450 mm in any timber length. It is also possible to reliably transport and precisely process several stacked workpieces without having to retool.

Extraction? Not necessary!

If desired, the SC-3 can cut the remaining usable wood recovered during the cutting process into small components or firewood-sized pieces. Chips, dust and rest wood drop down and are transported out on a conveyor belt. Extraction is not necessary.



Fast cutting with many other processing possibilities

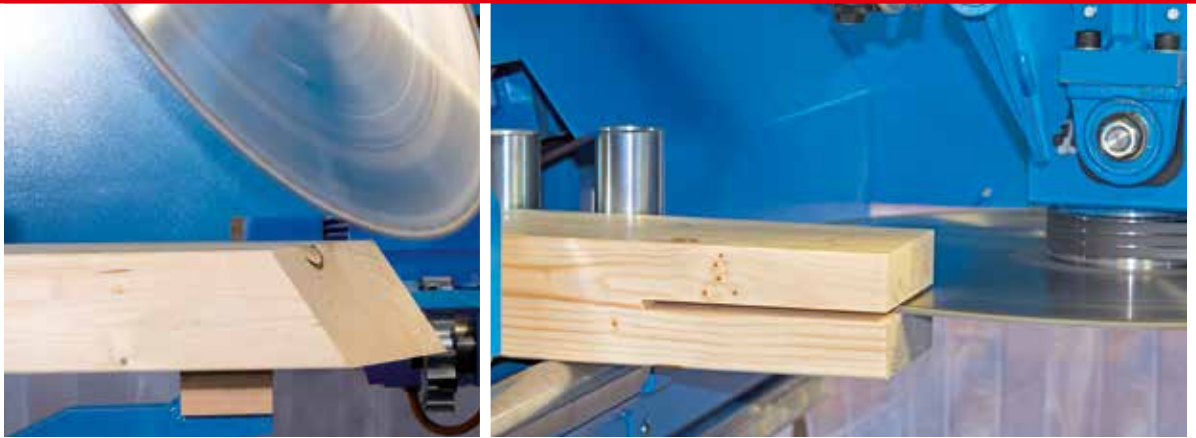

Pivoting saw

This powerful saw unit belongs to the standard equipment of the SC-3. Whether jack rafter cuts, hex cuts, regenerative cuts or diagonal cuts: The pivoting saw performs all types of saw cuts fully automatically and with millimetre precision – at any angle, at any inclination and in all lengths.

The saw unit with flangeless saw blade can be rotated through 360° and pivoted by 90°. The unit is therefore able to move underneath the supporting side of the workpiece to also allow birdsmouths, eave cuts or stair stringers to be cut.





CNC units for even more flexibility

This is how to turn the SC-3 into a versatile processing centre: If required, you can upgrade the machine with additional units and convenient accessories.



Turret mill

A universal unit that can be equipped with up to 3 tools. It can be used for many different processing operations: Wichert truss joint or scarf and key joint, roof ridge joint, offsets, birdsmouths, tenons at all positions, concealed recessing, and many others.

Use the turret mill for boring holes, making tenons or machining mortises on the end of the timber components.



Efficient and extremely precise milling: Longitudinal milling, eaves formwork notches and longitudinal rebates.



Vertical end mill

This vertical milling unit can be equipped with various milling tools – for milling rebates, recesses and freely definable profiles.



Stack processing

Special tools enable several parts stacked on top of each other to be processed simultaneously.



Vertical drilling unit

The vertical drilling unit is used to make through holes and blind holes.





Horizontal slot cutter

A unit that can be equipped with chainsaws of different widths. Apart from through slots, the unit can also be used to make concealed slots, e.g. for column bases and engineering Glulam structures.



Horizontal drilling unit

The horizontal drilling unit is used to make through holes or blind holes.



Double milling unit

Milling two parts simultaneously – the double milling unit makes this possible. This unit is mainly used to make milling grooves for flush-mounting ground plates and top plates.



Retractable outfeed area

When the part has been finished, the outfeed table is lowered. The gripper wagon can then immediately move back to the machine zone to clamp the next part and the part outfeed enters an idle time. The continuous feeding means an enormous production advantage!

Labelling system

Automatic labelling of elements immediately after processing so that they can be clearly identified: Barcodes and multiline text can be applied using vertical and horizontal writers as well as inkjet systems. Inkjet printing on stacked timber is also possible and widely used.

Dimensional measurement

This is used to automatically record dimensional deviations relative to the prescribed cross-section and then to take these deviations into consideration during processing.



Label printer

For labelling parts with all the necessary information. The data can also be imported from joinery and CAD programs.



Additional screen

The additional screen displays all relevant information graphically at the machine's outfeed. This ensures reliable and error-free identification of the finished parts helping the sorting and stacking process.



Collection conveyor for small parts

This allows even the shortest parts to be reliably separated from offcuts and transported out of the machine. This means more yield from otherwise waste wood.



Intelligent software – developed for everyday use

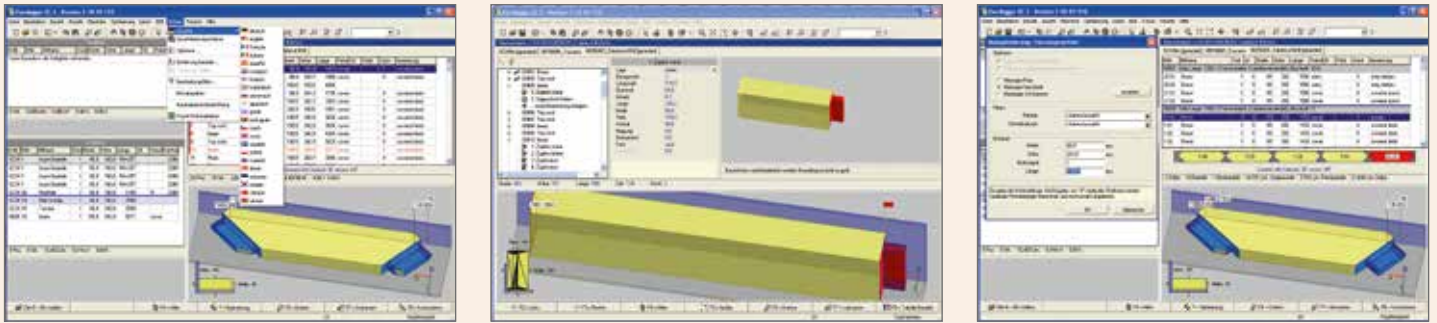

HUNDEGGER production program EKP

The Hundegger-EKP program is characterised by simple data input specifically adapted to the needs of timber construction, as well as a high level of operator-friendliness. All of the required data can be imported without postprocessing from joinery and CAD programs or entered directly in the EKP program.

The clear 3D visualisation supports the user and makes data input extremely easy. All wood nodes are stored as macros.

The construction project can be optimised according to different criteria.

Depending on the selected option, the various parts are optimised in the existing raw timber or the optimum raw timber length is suggested.

The language of the program can be changed to the respective user language using a simple selection process.

- Free software updates
- Automatic list generation (sawmill lists, cutting lists, roughcut lists, etc.)
- Integrated production data acquisition
- Management of timber stocks
- Freely programmable end mill
- Online help
- Cut-in-cut optimisation (board stretcher)
- Remote diagnosis and remote maintenance

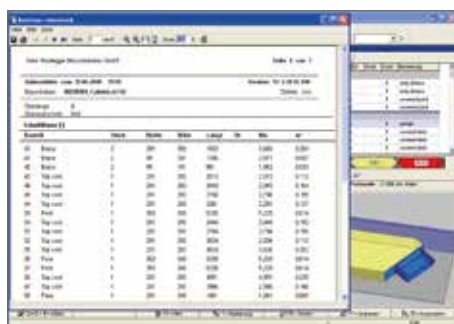

Board stretcher –guarantees optimum utilisation of timber, less waste and more yield.

Without Board-Stretcher 6,60 m



With Board-Stretcher 6,00 m

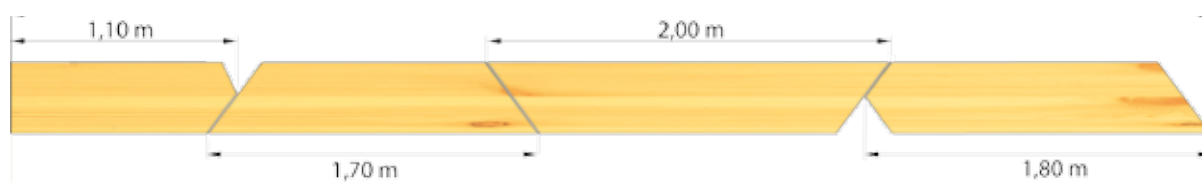

- 10 %

Reduced wood consumption = Increased profit

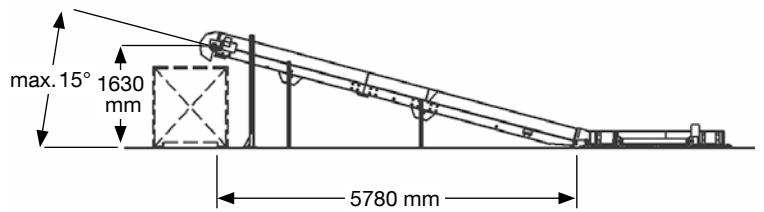
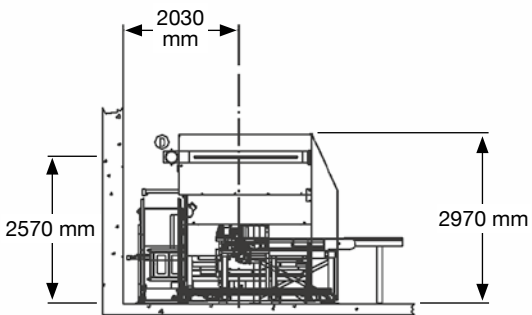
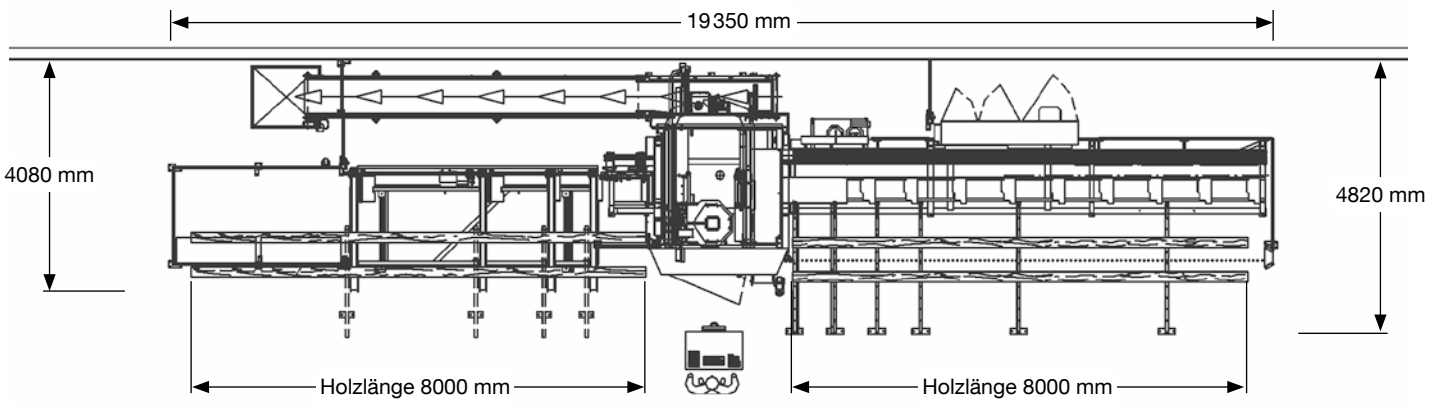
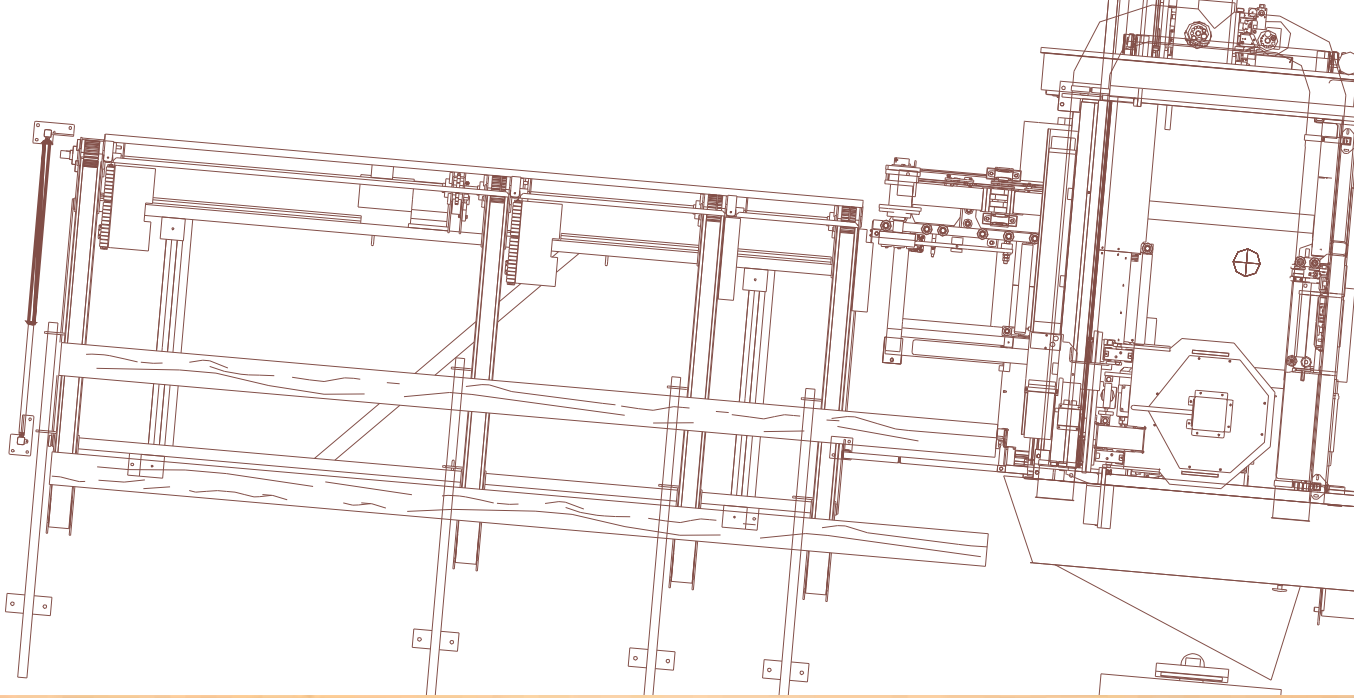

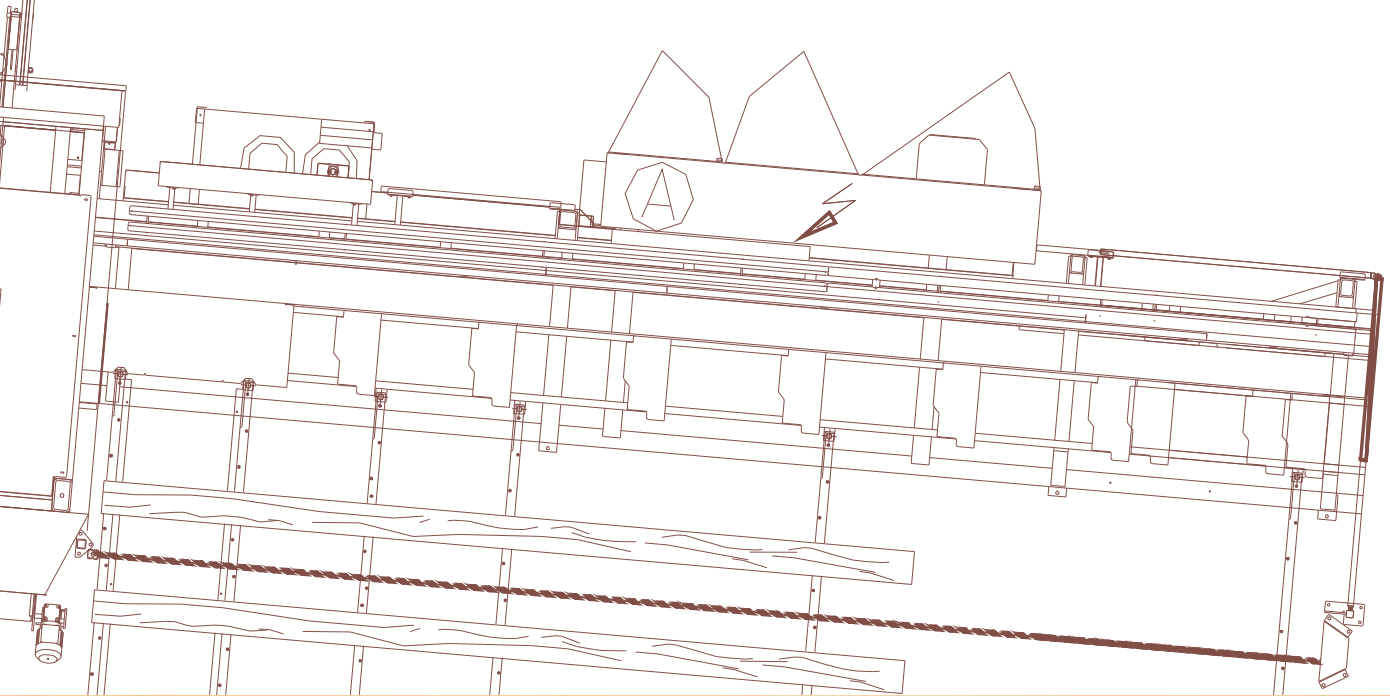

Some typical examples processed on the SC3 Machine.

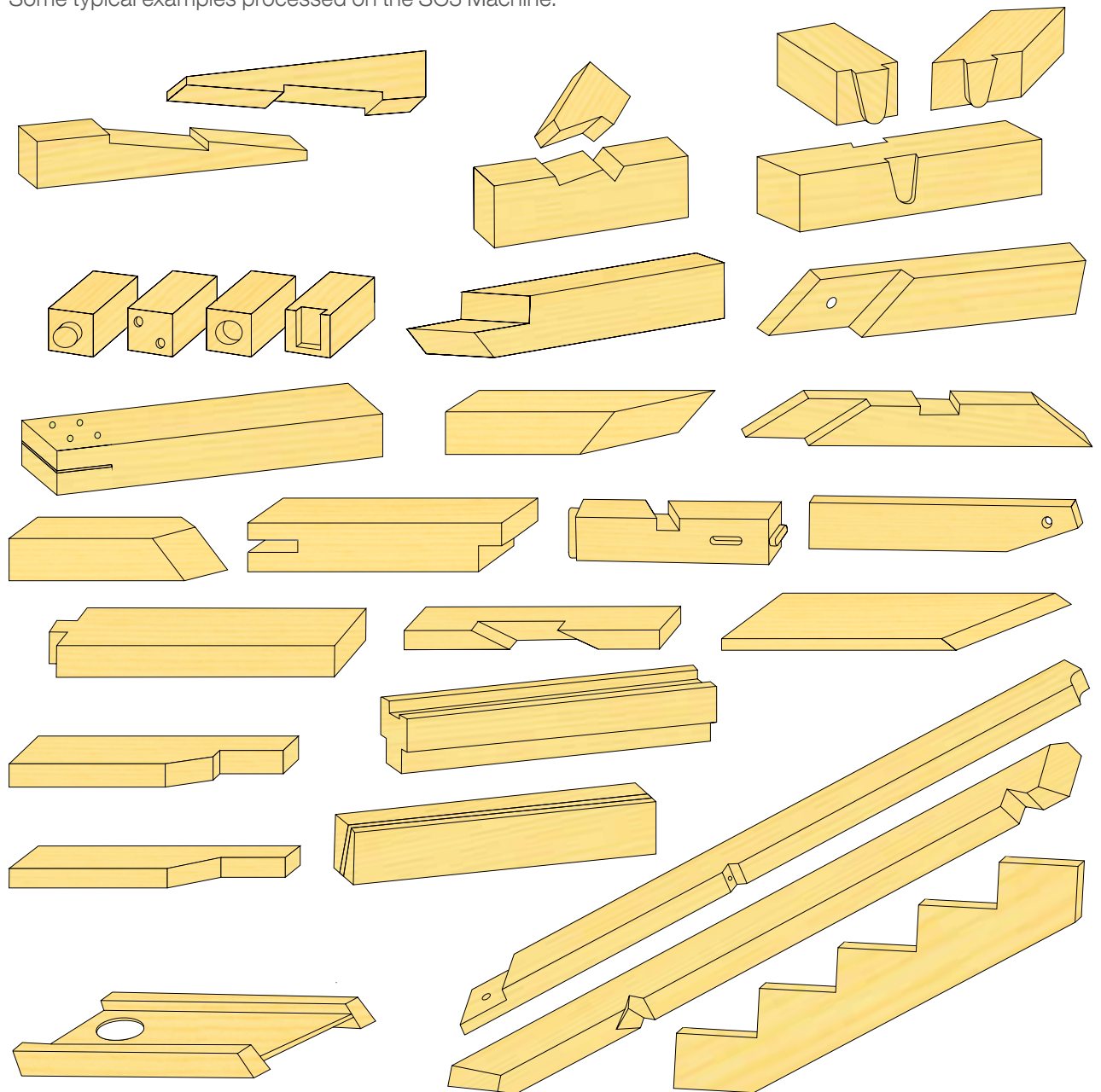



Hundegger – Advantages

- Experience from more than 4700 machines installed worldwide
- Precise adaptation of the machines to the requirements of the customer thanks to the modular system and expert advice
- High degree of flexibility owing to in-house software development
- Continuous further development and free software updates
- State-of-the-art interface compatible with all leading timber construction AD programs
- Convenient machine operation specially developed for the demands of timber construction
- Qualified training and courses at the Hundegger training centre
- Close cooperation with leading institutes and colleges, particularly with regard to vocational further education
- Extensive warranties
- Service and spare parts availability guaranteed worldwide
- Round-the-clock service as a cornerstone of Hundegger's corporate philosophy
- Unrivalled price/performance ratio

Hans Hundegger AG

Kemptener Strasse 1
D-87749 Hawangen

Telephone: + 49 (0) 8332 9233 0
Fax: + 49 (0) 8332 9233 11
info@hundegger.de
www.hundegger.de

