

**CONCEPT**

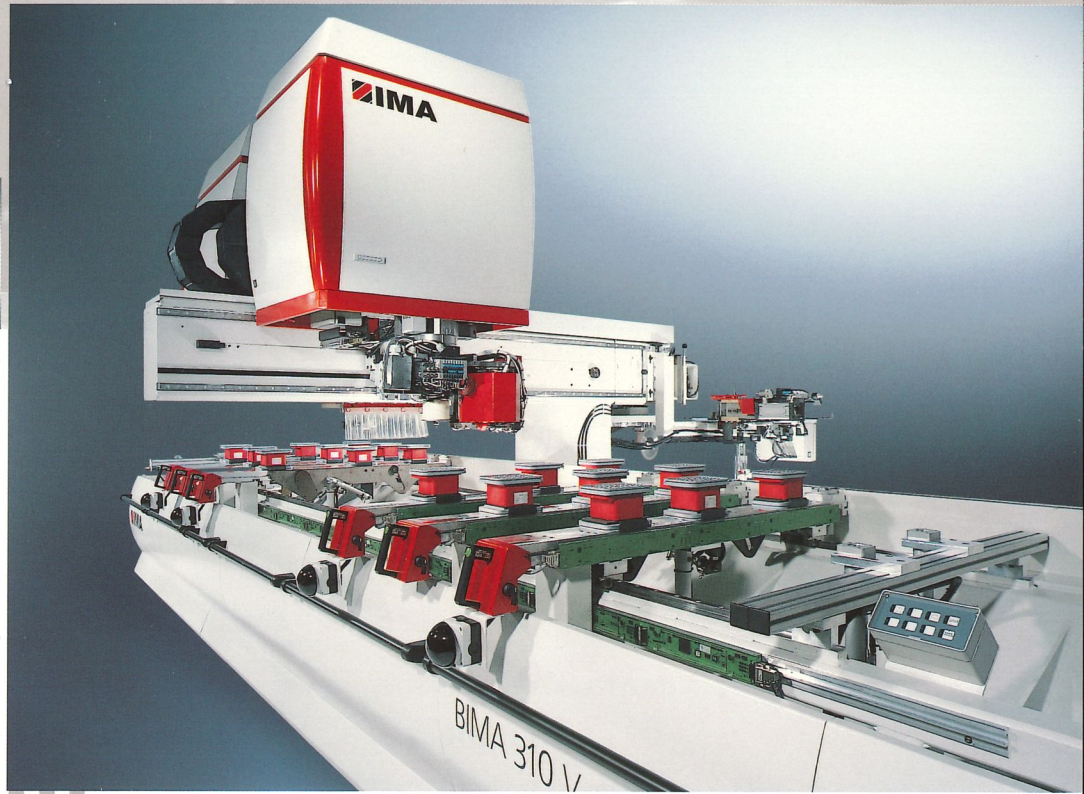

**BIMA 310 Concept**

for powerful complete processing



**BORING HEAD** ❖ TRAVERSE PATHS IN Y-DIRECTION

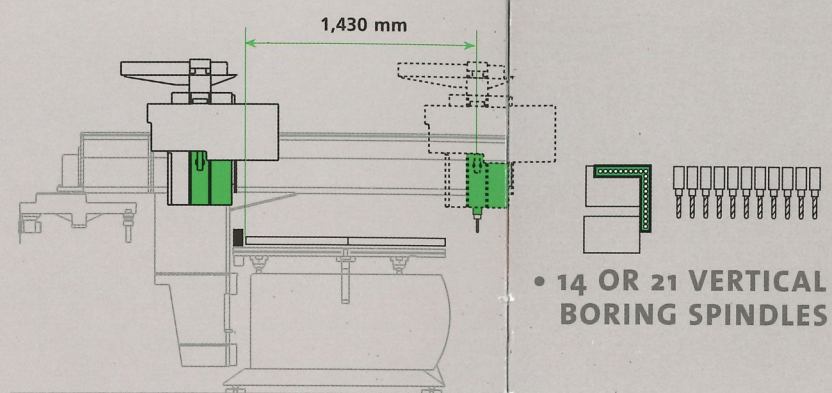
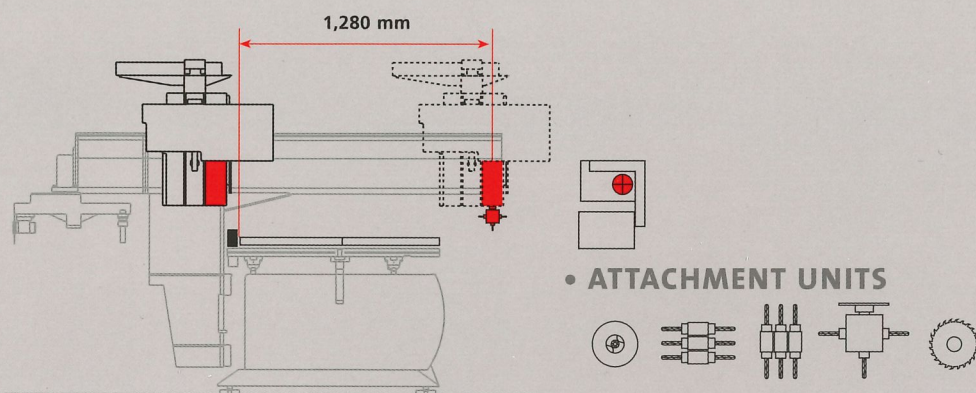

**MAIN SPINDLE + ADDITIONAL AUXILIARY SPINDLE**  
 ① 1,650 mm    ② 1,290 mm    ❖ TOOL PATHS Y-DIRECTION

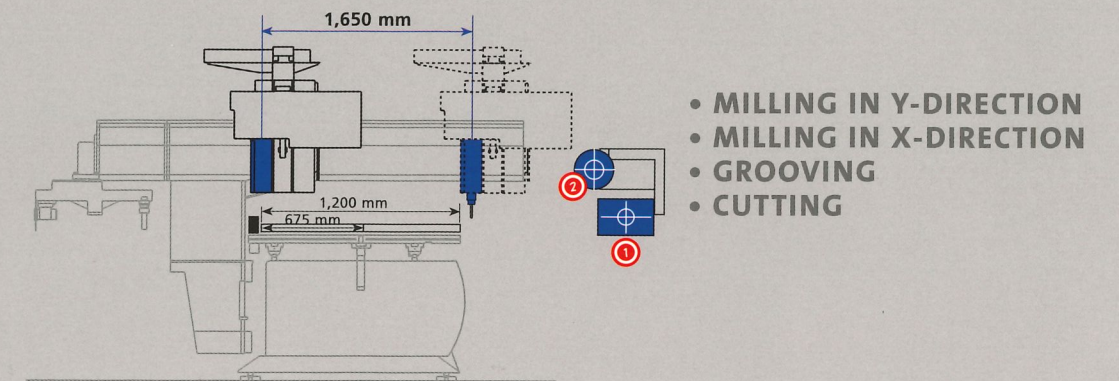

# BIMA 310 Concept

optimum productivity

**BIMA 310 V CONCEPT**

- Edge banding, routing and boring machine

**BIMA 310 CONCEPT**

- Routing and boring machine

The modular BIMA 310 Concept series – for a professional and cost-effective complete processing of furniture elements and interior design components.

It is suitable for production of large quantities as well as for batch size »1« – an investment that pay back very soon:

- ❖ Worktable sizes from 3,000 to 7,000 mm in X-direction
- ❖ Multi panel loading by using the 2nd row of Y stops (standard)
- ❖ Complete processing of panels due to IMA edge banding technology
- ❖ Individual choice of adapter units
- ❖ User-friendly, IMA advanced product design



BIMA 310 V Concept

BIMA CONCEPT • EGDE BANDING

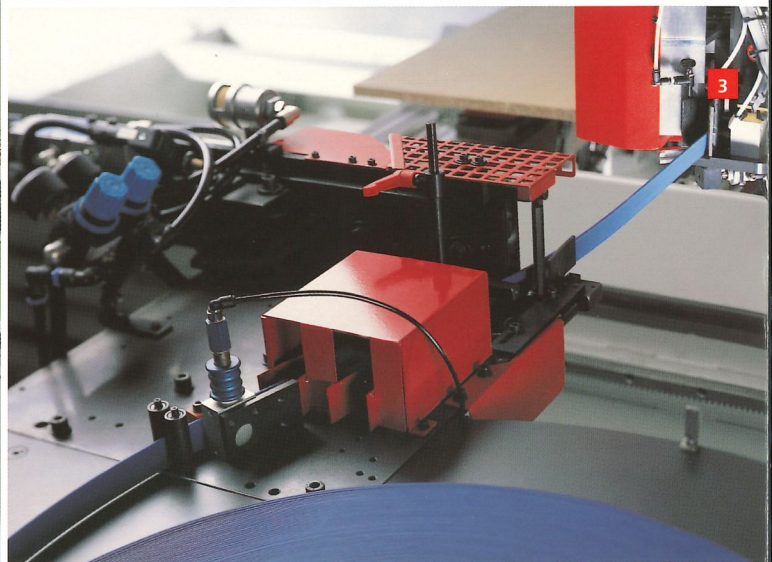
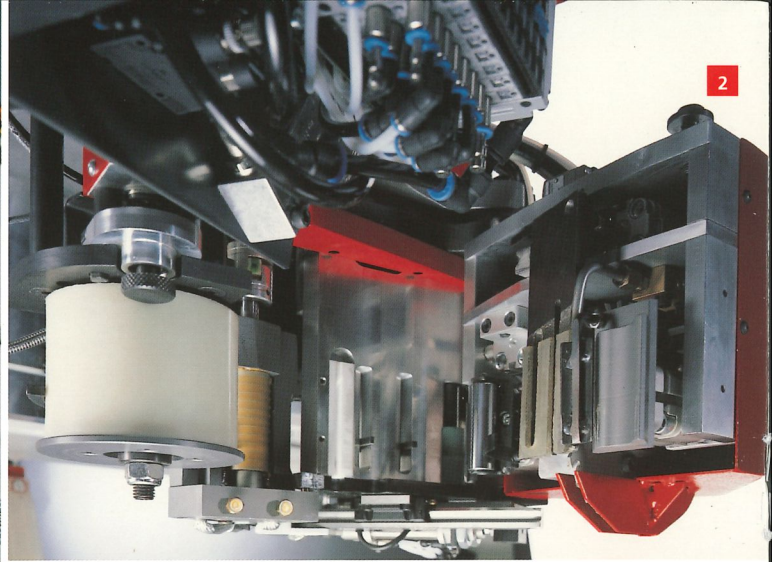
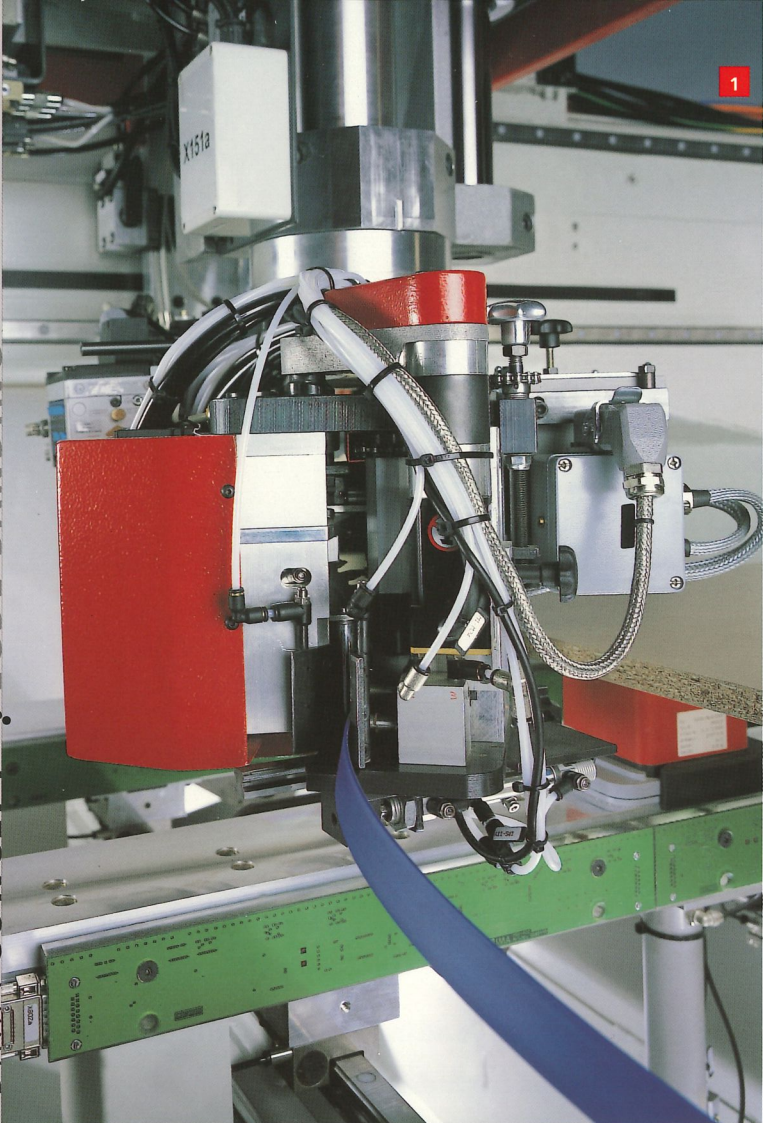

BIMA CONCEPT • BORING AND MILLING

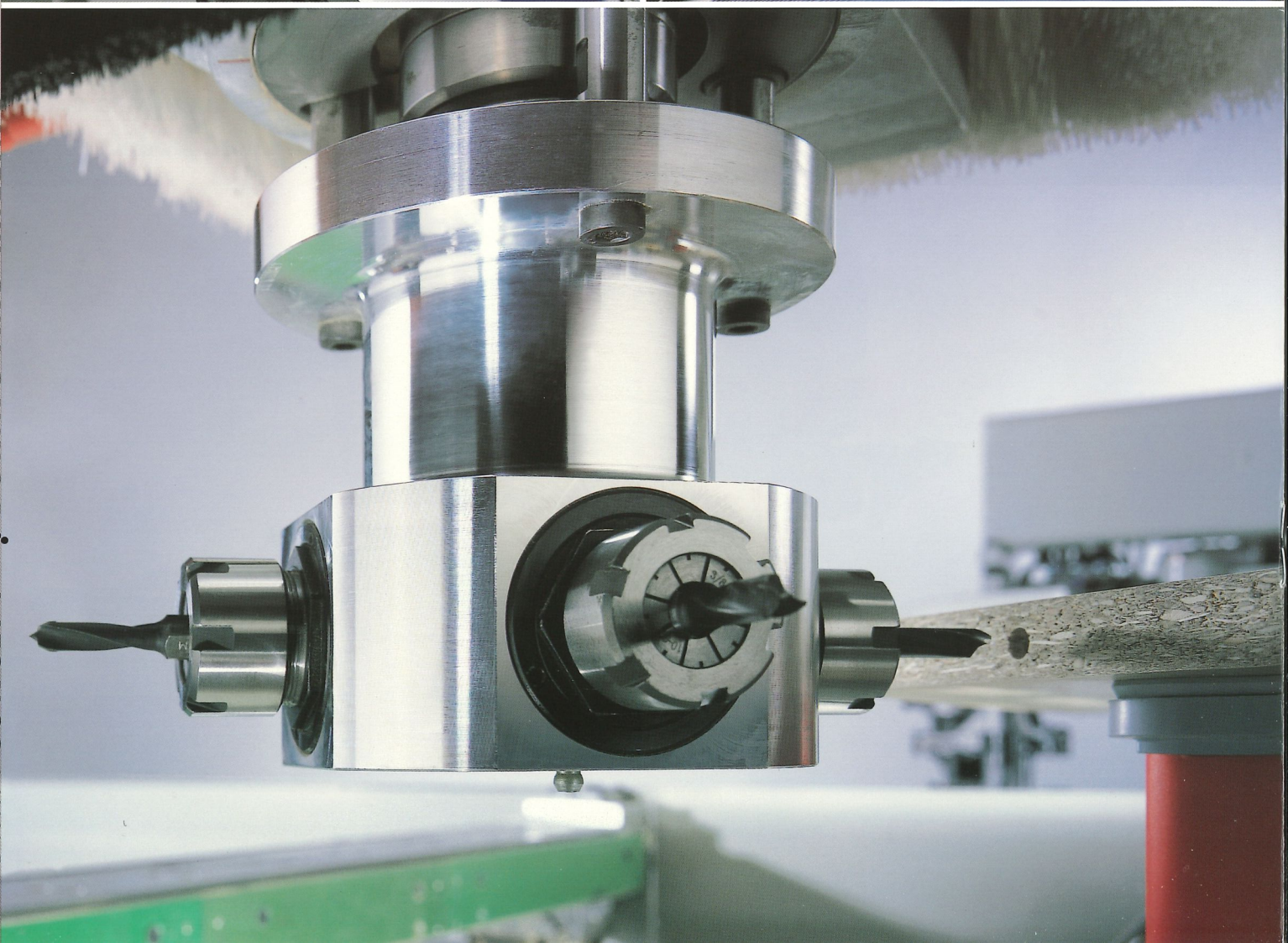

# BIMA 310 **Concept** value-added

- ❖ For routing with 7,5 kW, or 14,5 kW main spindle (optional)
- ❖ Tool changer with 18 positions allowing quick automatic access to the tools and adapter units
- ❖ Boring units with up to 21 drills for vertical and horizontal boring (boring spindles are individual selectable)
- ❖ Vacuum clamping system without hoses
- ❖ 1 open docking place for attachment units
- ❖ On the BIMA 310 V Concept the second side of the machine head holds the VT 50 edge banding unit with manual feeding of the edging tape or – as an optional extra – automatic feeding of the edging tape from a tape magazine travelling with the main spindle

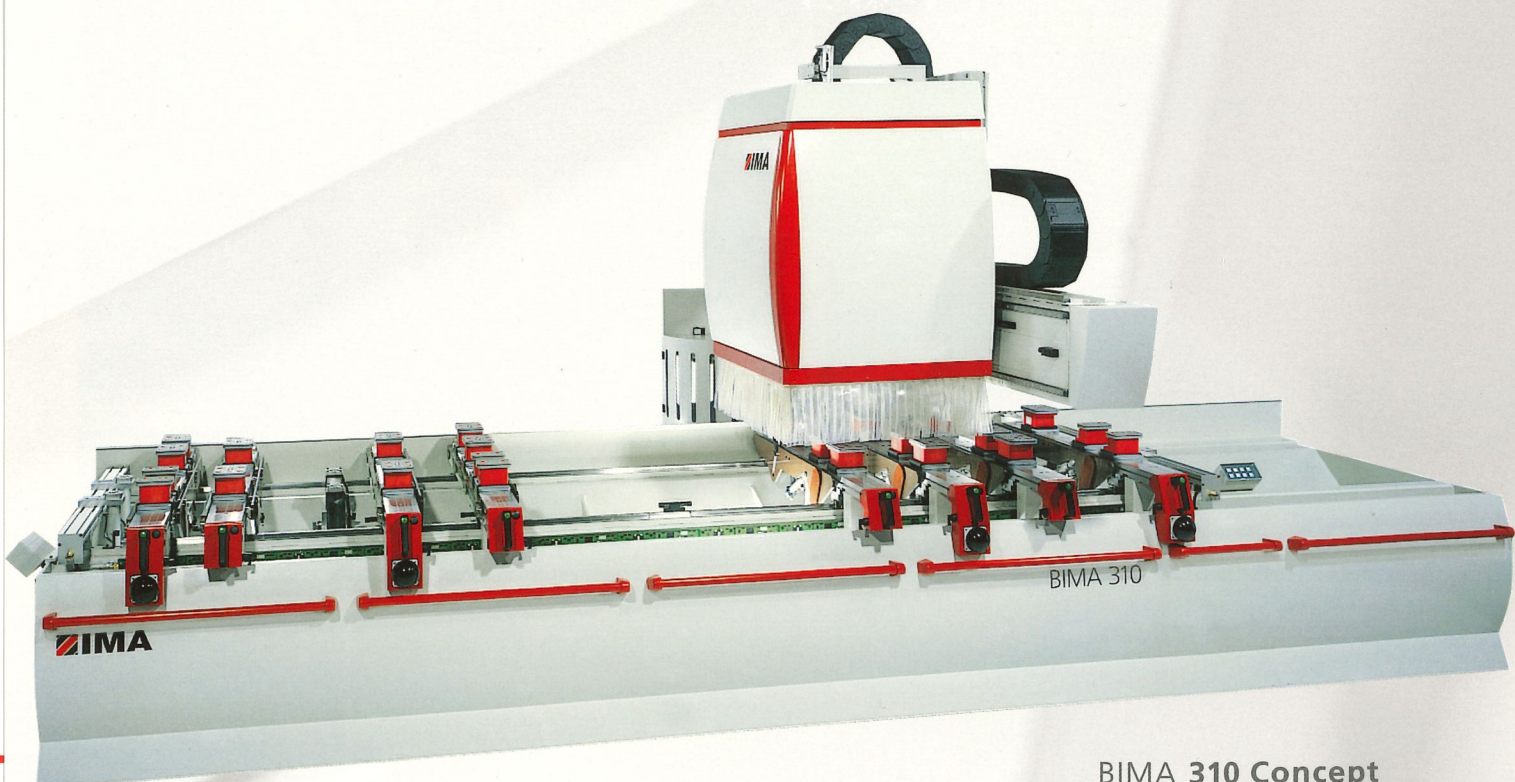

BIMA 310 Concept

- 1 Edge banding unit VT 50
- 2 User-friendly maintenance of the edge banding unit
- 3 Manual or automatic tape feeding from a tape magazine travelling with the cantilever

**The BIMA 310 V Concept does complete processing at one station.**

**The edge banding (4-sides, resp. 360° butt joint) is done by user friendly and reliable edge banding unit VT 50. Conventional hotmelts as well as PUR-hotmelts can be used.**

# BIMA 310 Concept for complete processing

**The vector-controlled main spindle of the BIMA 310 Concept and BIMA 310 V Concept offers a steplessly variable speed range of 0–24,000 rpm with the possibility of a maximum rpm torque starting at 0 rpm (optional).**

- ❖ **Integrated boring head**
- ❖ **C-axis 360° rotatable**
- ❖ **Tool changer for tools and adapter units**

**Boring head max. 21 drills,  
incl. 1 open docking place for attachment units**



**Main spindle with C-axis and adapter unit ›horizontal boring‹**



Combi adapter unit: flush-milling and flat scraper

18-station tool changer



Main spindle with C-axis and adapter unit saw





Panel loading using a second row of Y stops

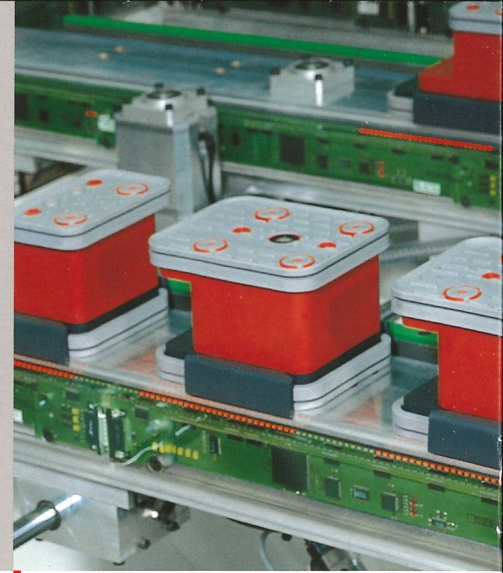

LED vacuum block positioning

# BIMA 310 Concept

## Worktable configuration

The BIMA 310 Concept has got a 2nd row of Y stops. There is 1 back stop and 1 stop at the center of each panel support rail. Work pieces of less than 600 mm width can be positioned against the center stops, work pieces wider than 600 mm are positioned against the back stops, The advantage of this worktable configuration: The zero point of the panel is constantly at the back. On the BIMA 310 Concept , 2 panels can be put behind each other in Y-direction as the worktable. It is possible to produce two identical panels or one left and one right-hand panel by using the mirror image function.

- ❖ If needed, special clamping devices for special production needs (such as window or facade elements) can be used on the panel support rails.

For example, large panels

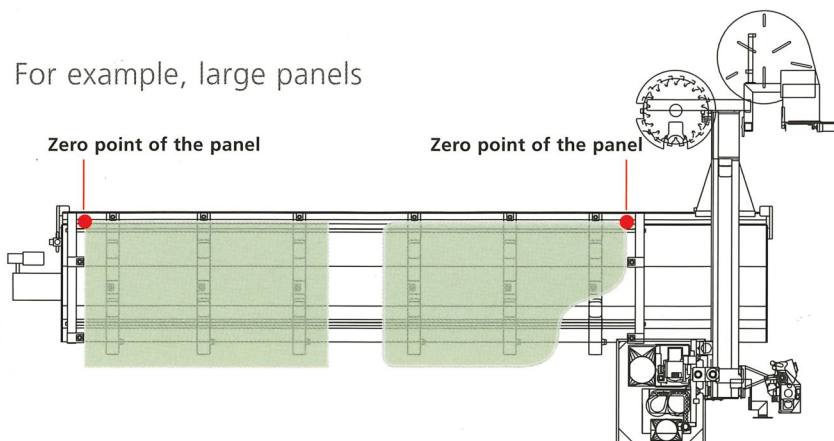

- Zero point of the panel ❖ back left and back right
- Optional extra Alternate panel loading with pendulum mode (safeguarding via pressure sensitive mats)

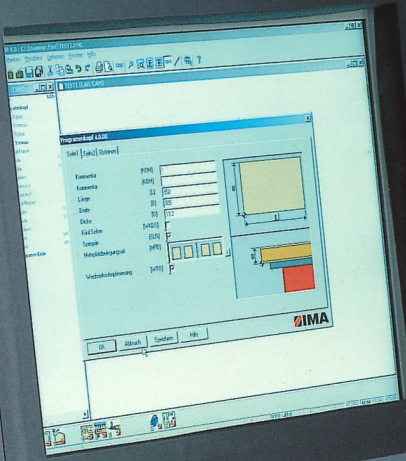

The IMAWOP controller enables drawing elements to be converted directly into work tasks.

- ❖ Easy menu operation – graphical user interface
- ❖ Automatic calculation of the vacuum block positions
- ❖ Display of machine and operating states, such as the current program, quantity, faults.





Vacuum clamping system without hoses

e.g. bach production

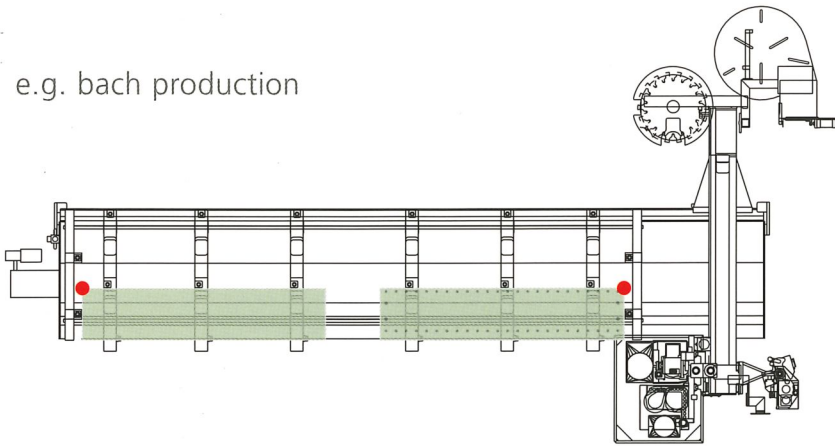

- Zero point of the panel** ↻ Back left, resp. back right
- 
- Standard** Alternate panel loading **with** pendulum mode (safeguarding via pressure sensitive mats)

e.g. work pieces mirror-imaged in Y-direction

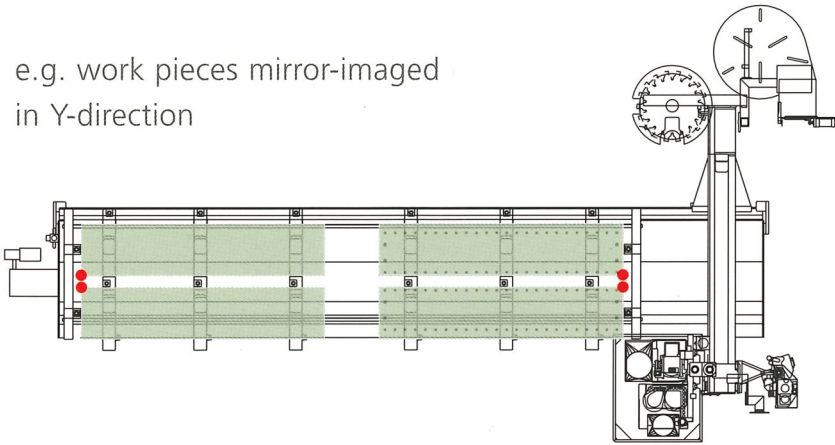

- Zero point of the panel** ↻ Back left, resp. back right
- Zero point of the panel** ↻ Front left, resp. front right
- 
- Standard** Alternate panel loading **with** pendulum mode (safeguarding via pressure sensitive mats)

e.g. production in large quantities

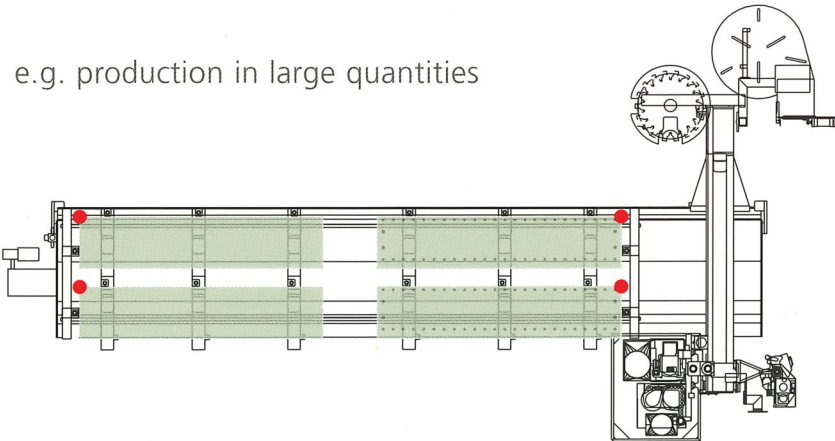

- Zero point of the panel** ↻ Back left, resp. back right
- Zero point of the panel** ↻ Front left, resp. front right
- 
- Standard** Alternate panel loading **with** pendulum mode (safeguarding via pressure sensitive mats)



Chip conveyor belt [optional]

e.g. production of larger panels  
in large quantities

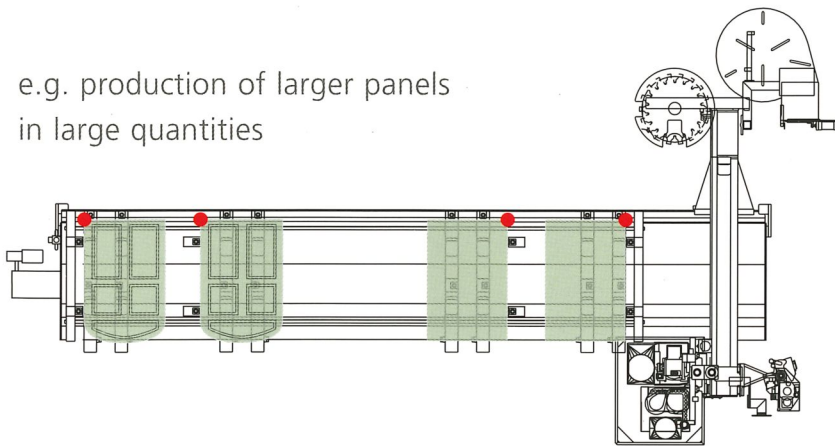

Optional extra  4-panel loading in X-direction

e.g. production of smaller panels  
in large quantities

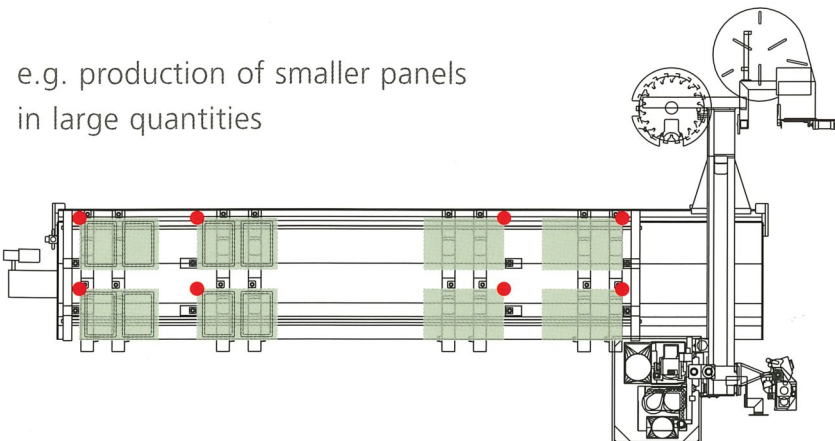

Optional extra  8-panel loading in X-direction  
(included in the ›4-panel loading in X-direction‹  
option; however, without split lifting rails and  
separate vacuum circuits in Y-direction  
 Vacuum clamping blocks with tracer valve  
(required)

# Main characteristics

## BIMA 310 CONCEPT

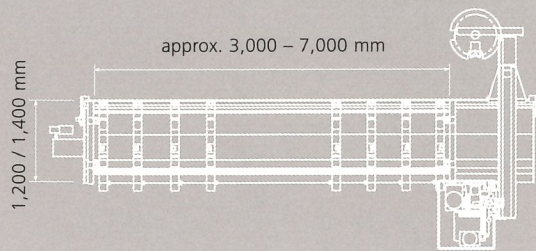

## BIMA 310 V CONCEPT

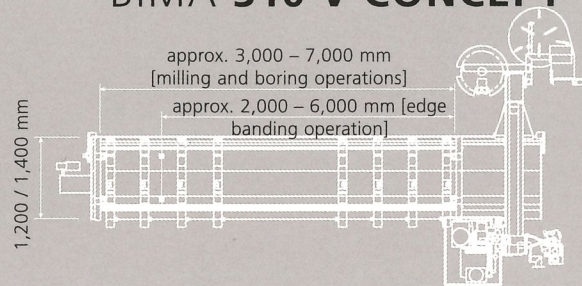

### BIMA 310 Concept [milling and boring machine]

### BIMA 310 V Concept [milling, boring and edge banding machine]

#### WORKING RANGE

X	3,000 / 4,000 / 5,000 / 6,000 / 7,000 mm	3,000 / 4,000 / 5,000 / 6,000 mm
Y	1,200 / 1,400 mm	1,200 / 1,400 mm

#### MACHINE

Main spindle power	7,5 kW with 100 % ED S1 operation	7,5 kW with 100 % ED S1 operation
Tool changer	18 stock positions, travelling in X-direction	18 stock positions, travelling in X-direction
vertical drills	14 or 21 C-axis 360°	14 or 21 C-axis 360°
Sound level	Operation under no load < 80 dBA	Operation under no load < 80 dBA
Stand-by operation	[depending on the tool, feed rate and material]	[depending on the tool, feed rate and material]
Central extraction connection	Ø 250 mm	Ø 250 mm

#### OPTIONAL EXTRAS

Main spindle	14,5 kW with 100 % ED S1 operation / 7,5 / 14,5 kW vector-controlled	14,5 kW with 100 % ED S1 operation / 7,5 / 14,5 kW vector-controlled
Horizontal drills	max. 6	max. 6
Grooving saw	90° rotatable	90° rotatable
2nd auxiliary router	max. 4,4 kW, 6 kW	max. 4,4 kW, 6 kW
	LED vacuum block positioning	LED vacuum block positioning
	Various adapter units	Various adapter units
	Chip conveyor belt	Chip conveyor belt
	Controlled panel support bars	Controlled panel support bars
	Central dust extraction with shut-off valve	Central dust extraction with shut-off valve
		Edge magazine travelling with the cantilever

Further optional extras on request

Subject to technical alterations and developments. The offer, respectively order confirmation are in any case the only relevant machine discription. The photographs may show the machine without complete safety equipment. However safety equipment will be supplied. Photographs may show options, which are not part of the standard execution.

Stand 11/2004



**IMA Klessmann GmbH**  
**Holzbearbeitungssysteme**  
 P.O. Box 12 46, D-32292 Lübbecke  
 Industriestraße 3, D-32312 Lübbecke  
 Germany  
 Fon +49 57 41 331 - 0  
 Fax +49 57 41 42 01  
<http://www.ima.de>  
 contact@ima.de