

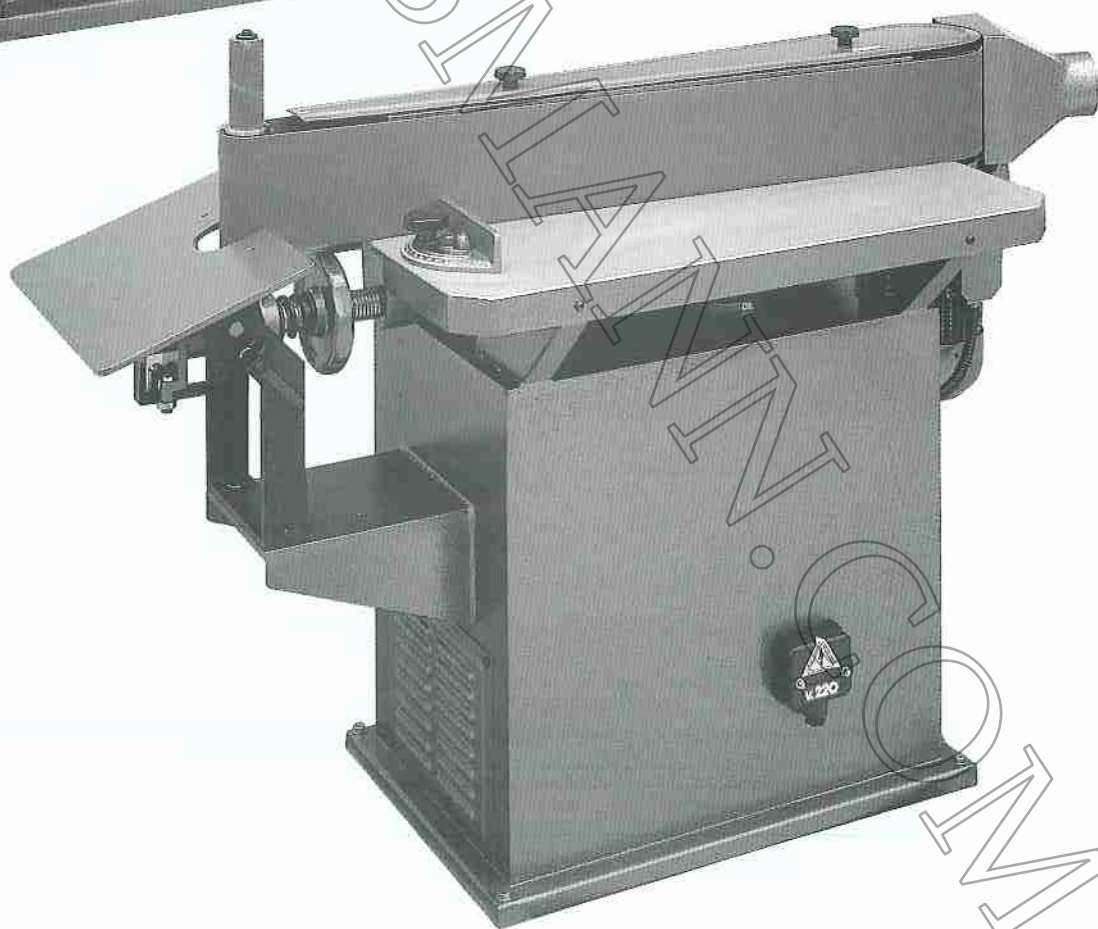

NTS-850

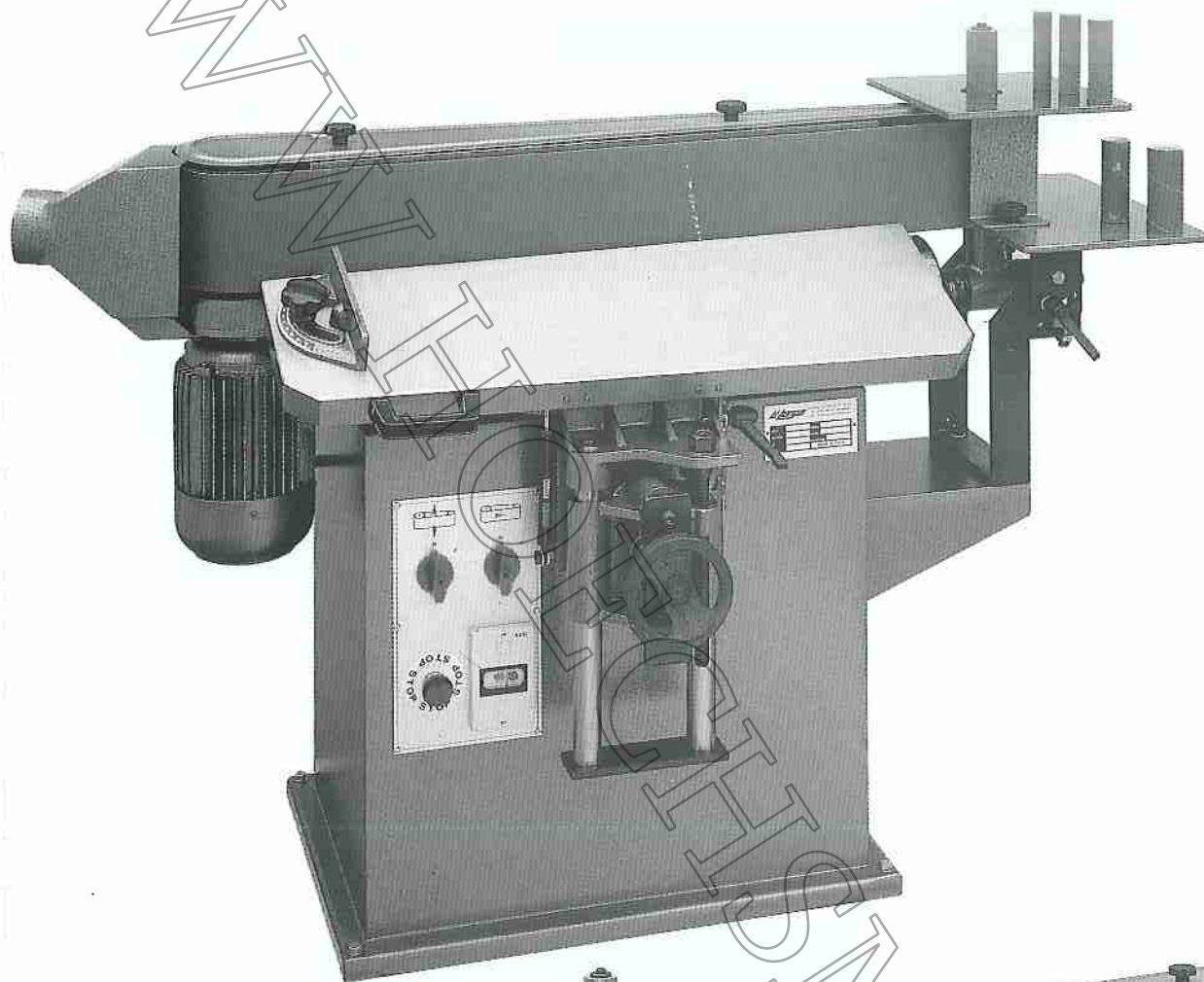

CARATTERISTICHE - SPECIFICATIONS CARACTERISTIQUES - DATEN - CARACTERISTICAS

Tavolo di lavoro inclinabile, regolabile sia verticalmente che orizzontalmente. Secondo tavolo di lavoro fisso. Tavoletto di lavoro supplementare per pezzi curvi inclinabile.

Tilting work-table adjustable both vertically and horizontally. Secondary fixed work-table. Supplementary tilting work-table for curve parts.

Table de travail inclinable, réglable aussi bien verticalement qu'horizontalement. Deuxième table de travail fixe. Table de travail supplémentaire pour pièces courbes.

Hauptarbeitstisch vertikal und horizontal verstellbar sowie neigbar. Fester Hilfsarbeitstisch. Zusätzlicher neigbarer Arbeitstisch für geschweifte Teile.

Mesa de trabajo inclinable, regulable ya sea vertical que horizontalmente. Segunda mesa de trabajo fija. Mesa de trabajo suplementaria para piezas curvas.

Piano di lavoro Work plane Plan de travail Arbeitsfläche Superficie de trabajo	12,6" x 37,8"	320 x 960 mm.
Inclinazione Inclination Inclination Schrägverstellung Inclinación	0° ÷ 30°	0° ÷ 30°
Lunghezza nastro Strip length Longueur de la bande Bandlänge Longitud cinta	104"	2640 mm.
Larghezza nastro Strip width Largeur de la bande Bandbreite Anchura cinta	6"	160 mm.
Rullo condotto Driven roll Rouleau conduit Leitwalze Rodillo conductor	Ø 3"	Ø 75 mm.
Bancalino di servizio per pezzi curvi Special sanding bed for curved pieces Table supplémentaire pour les pièces courbes Kleiner Tisch für Kurvenstücke Banqueta de servicio para piezas curvas	12" x 18"	300 x 450 mm.
Motore traino nastro Belt driving motor Moteur avancement bande Bandschleppmotor Potencia del motor de avance	5 HP	4 HP
Motore per oscillazione Motor for oscillation Moteur pour oscillation Motor für schwingungen Potencia del motor para oscilación	0,5 HP	0,5 HP
Corsa oscillante Oscillation stroke Oscillation Schwunglauf Oscilación	3/4"	20 mm.
Peso macchina Total weight Poids env. Gewicht Peso	772 Lbs	350 kg.
Misure di ingombro Overall dimensions Dimension d'encombrement Ausmaße Medida de obstrucción	32" x 67" x 45"	800 x 1700 x 1150 mm.
Dati e misure non sono impegnativi The data and measures are not binding Données et mesures ne sont pas obligatoires Gewicht und Ausmaße sind unverbindlich Detalles y medidas no son empenativos		



S.N.C.

Lasm s.n.c. di Volpato G. & C.
Via Pioga, 210 - I 35011 Campodarsego (PD) Italy - Tel. 049/5564039
Telex 430824 LASMAL - Telefax 0039 - 49 - 5566528