



masterwood

woodworking technology

PROJECT TF 80

FORATRICE "PASSANTE" A CONTROLLO NUMERICO PER PANNELLI
CNC POINT TO POINT THROUGHFEED BORING MACHINE
CENTRE D'USINAGE A COMMANDE NUMERIQUE DE PERCAGE PAR DESSOUS
CNC GESTEUERTE DURCHLAUFBOHR-, NUT- UND FRÄSMASCHINE
TALADRADORA DE PANEL PASANTE A CONTROL NUMÉRICO
FURADORA A CONTROLLO NUMÉRICO COM AVANÇO AUTOMÁTICO DO PAINEL

PROJECT TF 80



LA PICCOLA FORATRICE CNC PER GRANDI PROGETTI
THE SMALL CNC BORING MACHINE FOR GREAT JOBS
LA PETITE PERCEUSE CONCUE POUR LES GRANDS PROJETS
DIE KLEINE CNC BOHRMASCHINE FÜR GROSSE PROJEKTE
LA TALADRADORA PEQUEÑA PARA LOS GRANDES PROYECTOS
LA FURADORA PEQUENA PARA GRANDES PROYECTOS



Project TF 80 è la foratrice passante a controllo numerico “entry level” adatta a molteplici usi. Semplice e funzionale è l’ideale per l’artigiano.

Project TF 80 is the “entry level” CNC point to point throughfeed boring machine suitable for many uses. Its simple functionality makes it ideal for the craftsman.

La Project TF 80 est le centre de perçage par dessous à commande numérique de base qui s’adapte à toutes les utilisations. Simple et fonctionnelle, elle convient aussi bien à l’artisan qu’aux PMI.

Project TF 80 ist unter den CNC Durchlaufbohrmaschinen das “Einstiegsmodell”, geeignet für vielseitige Verwendungszwecke. Einfache Bedienung, ideal für den Handwerker.

La Project TF 80 es la taladradora de panel pasante a control numérico básica que se adapta a todas las utilizaciones. Sencilla y funcional, conviene al artesano.

Project TF 80 é a furadora a controlo numérico com avanço automático do painel apropriada para muitos usos. Simples e funcional, é ideal para o artesão.

DIMENSIONI DI INGOMBRO
OVERALL DIMENSIONS
DIMENSIONS
MASCHINENABMESSUNGEN
DIMENSIONES
DIMENSÕES

CAMPI DI LAVORO E CORSE
WORKING ZONES AND AXIS STROKES
ZONES DE TRAVAIL ET COURSE
MIN. UND MAX. WERKSTÜCKABMESSUNG
ZONAS DE TRABAJO Y DESPLAZAMIENTOS
CAMPOS DE TRABALHO E CURSOS

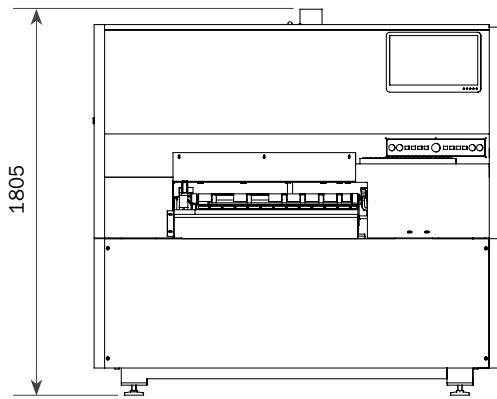
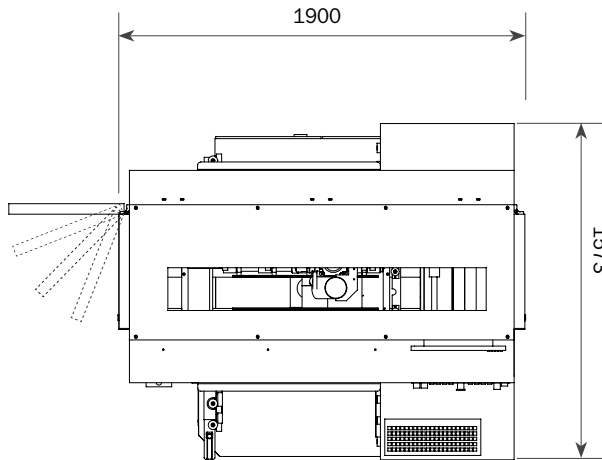
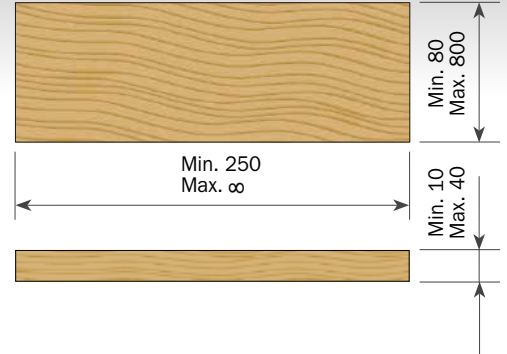

TESTA DI FORATURA
DRILLING HEAD
TETE DE PERCAGE
BOHRKOPF
CABEZA DE PERFORACIÓN
CABEÇA DE PERFURAÇÃO

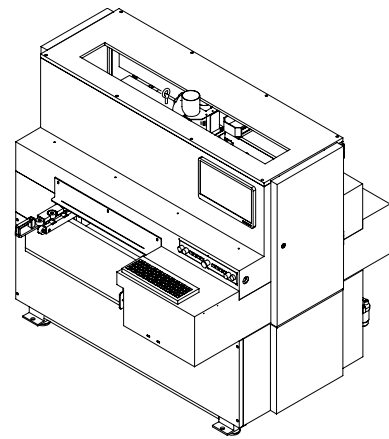
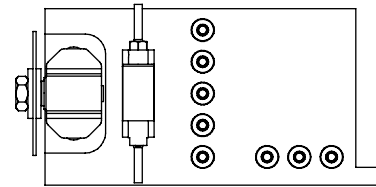

masterwood
woodworking technology

Via Romania, 20
47921 Rimini - Italy
Telephon +39 0541 745211
Telefax +39 0541 745351
www.masterwood.com
marketing@masterwood.com

Le illustrazioni e i dati contenuti nel presente prospetto non sono impegnativi. - The pictures and the data contained in this brochure are not binding.
Les illustrations et les données contenues dans ce dépliant ne nous engagent pas. - Die in diesem Prospekt vorhandenen Abbildungen und technischen Daten sind unverbindlich.
Las ilustraciones y los datos contenidos en el presente folleto no crean obligación alguna. - As ilustrações dados contidos neste catalogo, não são impenhativos.