



TM



www.ogdeninc.com

CNC RESAW



In a class by itself

Finally, a heavy-duty horizontal band saw for all your resawing applications, including flooring, windows doors, furniture and musical instruments.

Unlike other resaws, the REMAX 500 is built from solid cast iron, and incorporates a durable and effective guiding system and thin-kerf saw blades under high tension. The machine produces a smooth, glueable surface with superior tolerances.

The REMAX 500's modular construction gives your company room to grow. A single, stand-alone unit can be purchased initially; additional units can then be added in line as production requirements demand.

Put these advantages to work in your operation

- Heavy-duty, cast-iron construction—built for longevity and superior tolerances
- Thin-kerf, high-tension blades to minimize your waste
- Produces smooth, glueable surface
- Handles material to 15" wide, 6" thick
- Variable feed 10 fpm to 200 fpm



Modular design: add units for multiple cuts in a single pass



CNC touch-screen control panel for easy height adjustment of one or multiple heads

Features and specifications

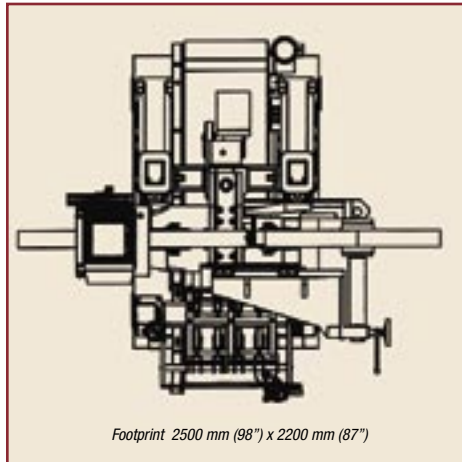
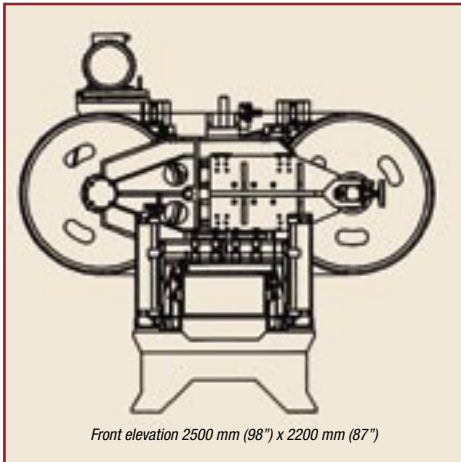

Technical specifications

Number of heads	1 or multiple
Machine voltage	3 phase (per customer specifications)
Main motor	15 kW to 22 kW (20 hp to 30 hp)
Feed speed	6 to 60 m/min (10 to 200 ft/min)
Pulley diameter	1000 mm (39")
Cutting width (adjustable)	500 mm (15")
Maximum cutting thickness	150 mm (6")
Minimum board length	300 mm (12")
Minimum slat thickness	2 mm (.080")
Cutting accuracy	± 0.10 mm (.004")
Saw kerf	1.0 to 1.5 mm (.040 to .055)
Saw blade life	20 to 80 hrs depending on wood and blade tooth material

The Neva collaboration



Since the late 1990s, Ogden Enterprises and Neva Trade have worked cooperatively to share knowledge and resources in the field of thin-cutting technology. Through the strength of our ongoing relationship, our two companies have successfully taken this technology to the next level. Ogden Enterprises and Neva Trade have combined their vast engineering and manufacturing resources to build the REMAX 500 CNC jointly from their facilities in the United States and the Czech Republic.

Machine dimensions

Width	2500 mm (98")
Length	2200 mm (87")
Height	2200 mm (87")
Weight	4000 kg (9000 lbs)

Detailed features

- Cutting width up to 500 mm (15")
- Feed speed from 10 to 60 m/min (35 to 200 ft/min) variable via frequency inverter
- Blade cutting speed infinitely variable depending upon type of wood and feed speed
- Infinitely adjustable saw blade tensioning
- Cast iron main frame offers sturdy construction for minimal machine vibration during production
- Air-loaded hold-down shoes prevent movement of lumber during cutting
- CNC touch-screen control panel for easy height adjustment of one or multiple heads
- Modular system can be purchased with a single sawing unit or multiple sawing units that are controlled via a central touchscreen

For detailed application information, call Ogden Enterprises at 704-845-2785

ogden
enterprises, inc.

1320 Industrial Drive
Matthews, NC 28105 USA
Tel 704-845-2785 • Fax 704-845-1023
www.ogdeninc.com