

quaranta 40-04



40-04 NEW





Le nostre macchine calibratrici levigatrici della serie 40-04 sono state espressamente progettate e realizzate per i piccoli artigiani.

Si tratta di una serie di macchine in larghezza di lavoro 600 – 950 e 1100 mm a 1 e 2 nastri, con sviluppo dei nastri abrasivi di 2150 mm.

Il modello standard è destinato alla calibratura e levigatura di massiccio; a richiesta – **serie 40-04/A** – è possibile anche la levigatura di superfici impiallacciate.

Tutte le macchine sono in esecuzione "CE".



Our calibrating sanders of the series 40-04 has been particularly conceived and manufactured for the joinery shops.

The series features machines with working width 600 – 950 and 1100 mm, with 1 and 2 belts, length of the abrasive belts 2150 mm.

The standard execution of these machines is suitable for calibrating and sanding of solid wood; Upon request – see **series 40-04/A** – the machines are also suitable for the sanding of veneered surfaces. All models with "CE" execution.



Nos machines calibreuses ponceuses de la série 40-04 ont été spécialement conçues et réalisées pour les artisans.

Les machines de cette série sont livrables en largeur de travail 600 – 950 et 1100 mm., avec une ou deux bandes et avec longueur des bandes 2150 mm.

Les machines dans l'exécution standard sont destinées au calibrage et ponçage du bois massif. Sur demande – v. **série 40-04/A** – il est possible le ponçage des surfaces plaquées. Toutes les machines sont exécutées suivant les normes "CE".



Unsere Kalibrier- und Schleifmaschinen der Baureihe 40-04

sind besonders für die kleinen Handwerke durchdacht und realisierte worden:

Aus dieser Baureihe sind Maschinen in der Arbeitsbreite 600 – 950 und 1100 mm und mit 1 und 2 Schleifbändern und mit Schleifbandlänge 2150 mm lieferbar.

Das Standard-Modell ist zum Kalibrieren und Schleifen von Massivholz geeignet; Auf Wunsch – s. **Baureihe 40-04/A** – können die

Maschinen auch zum Schleifen von furnierten Oberflächen ausgerüstet werden. Die sämtlichen Maschinen sind nach den "CE" Vorschriften gebaut.



Nuestra maquina lijadora calibradora de la serie 40-04

han sido diseñadas y realizadas para el pequeño artesano. Se trata de una gama que comprende máquinas con ancho de trabajo de 600 950 y 1100 mm y con 1 y dos grupos de lijado. Con desarrollo de banda de 2150 mm. El modelo standard esta indicado para el lijado y calibrado de macizo, y sobre pedido - **serie 40-04/A** - es posible realizar también el lijado de chapa.

Todas las maquinas cumplen la normativa "CE".



A nossa lixadora calibradora da série 40-04 foi expressamente projectada e concebida a pensar nas pequenas carpintarias e marcenarias.

Trata-se de uma máquina que trabalha com largura de 600 – 950 e 1100 mm, com 1 e 2 grupos com comprimento de lixas de 2150 mm. O modelo standard desta máquina é apropriado para calibrar e lixar madeira maciças; como opcional – **Serie 40-04/A** – é possível também lixar superfícies folheadas.

Todos os modelos têm normas "CE".

Composizioni delle macchine 40-04

Compositions of the machines - Maschinenausführungen
Executions des machines - Combinaciones - Combinadas

Sviluppo nastri abrasivi - Length of the abrasive belts - Schleifbandlänge -
Longueur bandes abrasives - Comprimento das cintas de lixa - Desarrollo banda abrasiva

2150 mm

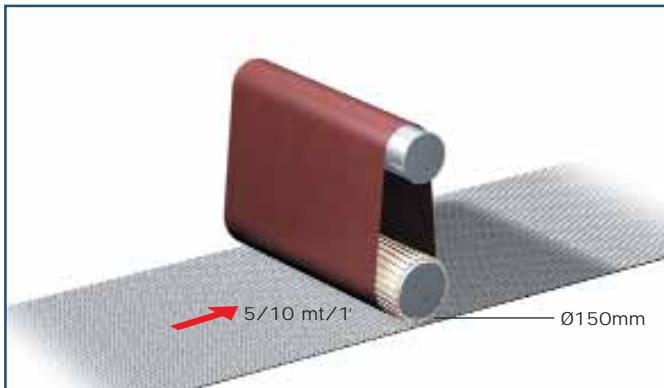

W

W600

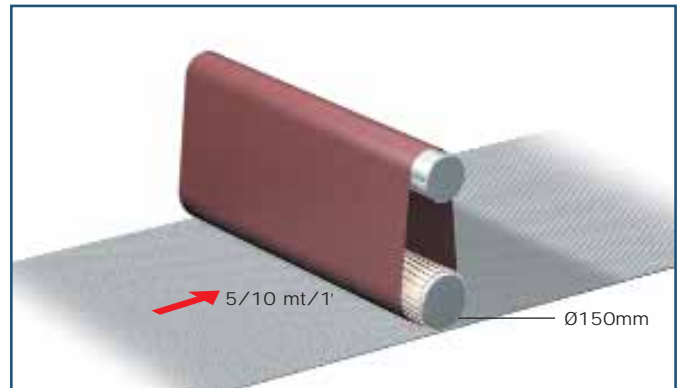

W

W950

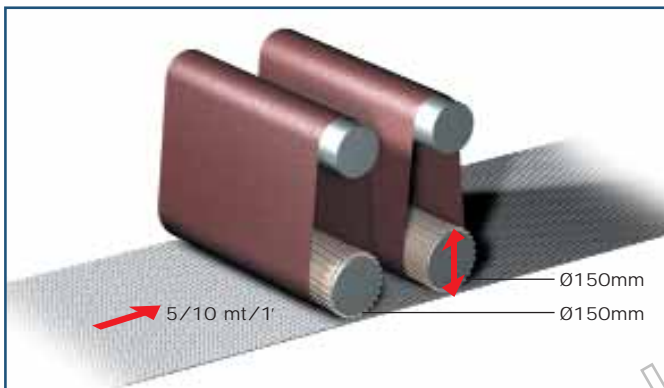

2W

2W600

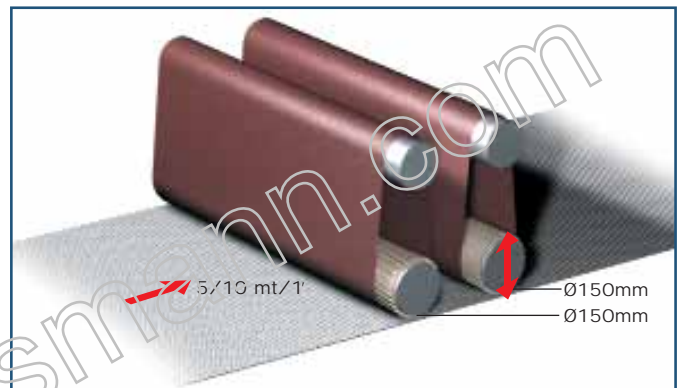

2W

2W950

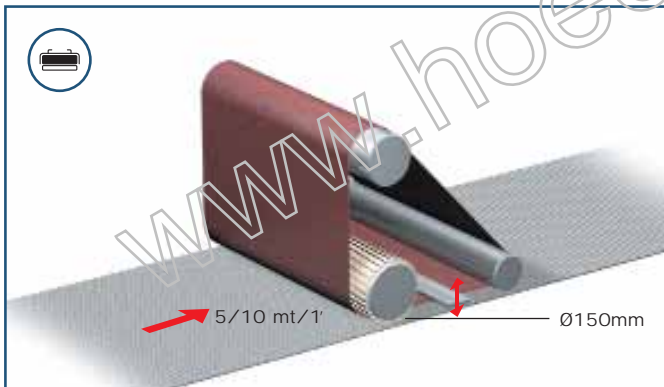

K

K600

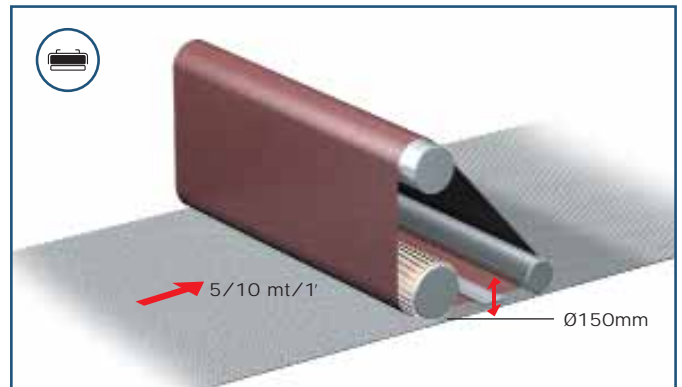

K

K950

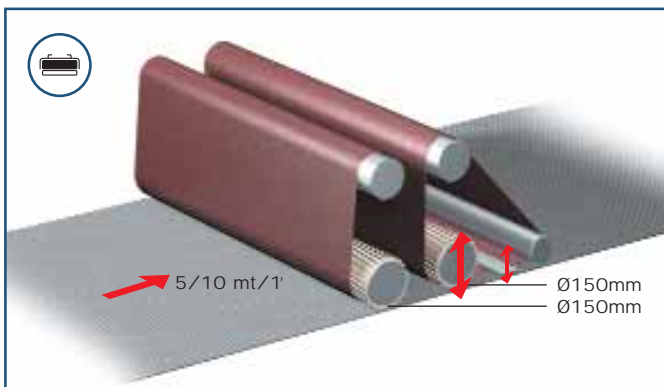

WK

WK1100

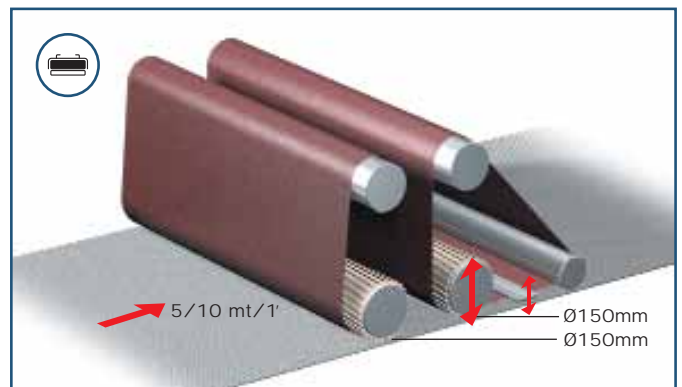

WK

WK950

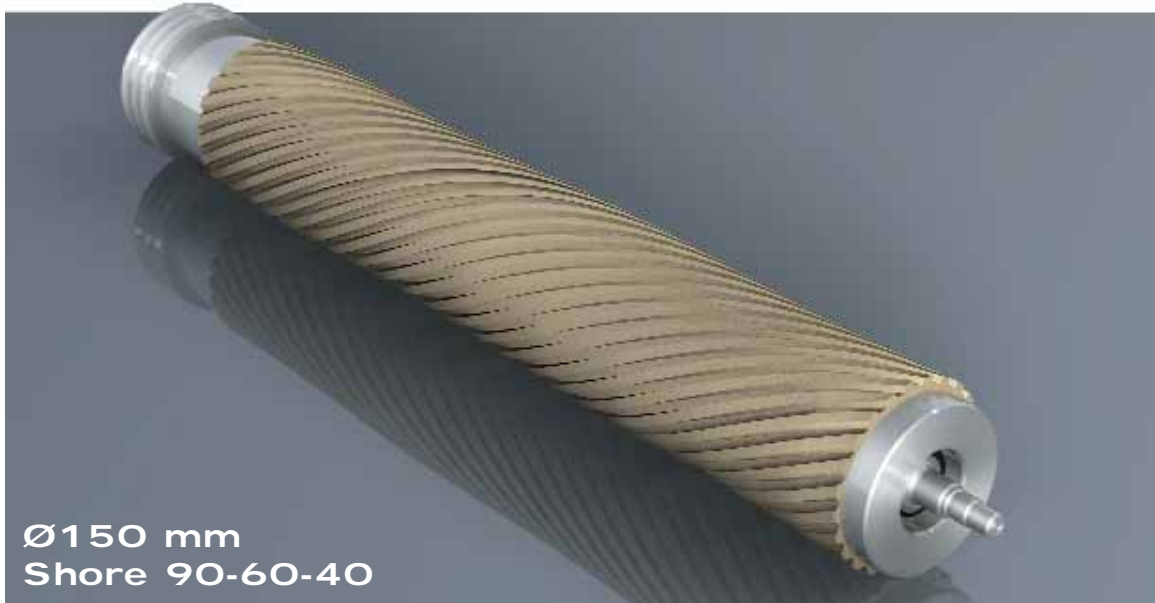

Ø150 mm
Shore 90-60-40



Rulli di contatto

1° rullo di diametro 150 mm
90 shore.

2° rullo di contatto diametro
150 mm gommato durezza
Shore a scelta e regolazione
manuale in altezza.

Tamponi

Il modello "K" e "WK" è di serie
dotato di tampone finitore rigido
per massiccio.

Esecuzione base macchina.

Sollevamento motorizzato del
piano completo di visualizzatore
2 velocità di avanzamento tasta-
tori superiori a rulli gommati; rui-
liera in entrata ed uscita; esecu-
zione "CE".



Kontaktwalzen

1. Kontaktwalze Durchmesser
150 mm; 90 shore

2. Kontaktwalze gummiert mit
entsprechender Härte
Durchmesser 150 mm mit
Handhöhenverstellung.

Schleifschuh

Die Modelle „K“ und „WK“ sind
serienmäßig mit dem starren
Schleifschuh für Massivholz
ausgerüstet.

Grundausführung der Maschine

Motorisierte Tischhöhenverstel-
lung mit Anzeige;
2 Vorschubgeschwindigkeit;
Obere gummierten Druckrollen;
Rollentisch im Ein- und Auslauf;
"CE" Ausführung.



Contact rollers

1st contact roller dia. 150 mm.
90 shore.

2nd contact roller dia. 150 mm
rubber coated with suitable
hardness and with manual
height adjustment.

Sanding pad

The models "K" and "WK" are
standard equipped with the rigid
sanding pad.

Basic execution of the machine

Motorized height adjustment
of the table complete with
readout; 2 feed speed; upper
pressure steel rollers rubber
coated; rollers table at infeed
and outfeed; "CE" execution.



Rouleaux de contact

Premier rouleau diamètre 150
mm. 90 shore.

Deuxième rouleau caoutchouté
diamètre 150 mm dureté Shore
correspondant.

Patin

Les modèles " K " et " WK "
sont équipés de série avec le
patin de finition rigide pour massif.

Exécution de base des machines

Réglage en hauteur de la table
avec visualisateur;
2 vitesses d'entraînement;
Rouleaux supérieurs de pression
caoutchoutés ;
Banc à rouleaux a l'entrée et a
la sortie. Exécution " CE "



Rodillo de contacto

1° Rodillo de diámetro 150 mm
90 shore

2° Rodillo de contacto diámetro
150 mm engomado con dureza
a elegir y regulación manual en
altura.

Patin

El modelo K y el modelo WK
incorporan de serie un patin de
acabado rigido para macizo.

Equipamiento base de la maquina

Subida y bajada motorizada de la
mesa con visualizador.
2 velocidad de avance.
Palpadores superiores con rodil-
lo engomado.
Rodillos en entrada y salida.
Normativa "CE".



Rolo de contacto

1° rolo com diâmetro 150 mm
90 shore

2° rolo com diâmetro 150 mm
revestido a borracha com dure-
za apropriada e elevação
manual.

Patim

Os modelos "K" e "WK" são
equipados de série com patim
rígido para madeira maciça.

Equipamento base da máquina

Elevação motorizada da mesa
com visualizador.
2 velocidade de avançamento
Calçadores superiores em rolos
de aço revestidos a borracha
Rolos de apoio à entrada e à
saída da mesa. Normas "CE".



Calibratrice levigatrice a 2 nastri con 1° rullo diametro 150 mm e 2° rullo diametro 150 mm gommato Shore 60° con regolazione manuale in altezza, sviluppo nastri 2150 mm.



Calibrating sander- 2 belts - with the 1st roller dia 150 mm, 2nd roller dia 150 mm rubber coated Shore 60° with manual height adjustment, length of the belts 2150 mm.



Calibreuse - Ponceuse à deux bandes avec 1er rouleau diamètre 150 mm et 2ème rouleau caoutchoute 60° Shore diamètre 150 mm avec réglage manuel en hauteur, longueur des bandes 2150 mm.



Kontaktschleif- und Kalibriermaschine mit 2 Bändern mit der 1. Walze Durchmesser 150 mm und mit der 2. Kontaktwalze gummiert 60° Shore mit Handverstellung; Schleifbandlänge 2150 mm.



Calibradora lijadora de dos bandas con 1 rodillo de diámetro 150 mm y 2° rodillo de diámetro 150 mm engomado 60° shore con regulación manual en altura, desarrollo de banda 2150 mm



Lixadora calibradora de 2 grupos - 1° grupo com rolo de diámetro 150 mm e 2° grupo com rolo de diámetro 150 mm revestido a borracha de 60 sh de dureza, com elevação manual e comprimento das lixas 2150 mm.



Motore di comando con freni a disco (di serie)
Main motor with disc brakes (standard)
Moteur de commande avec les freins à disques (standard)
Antriebsmotor mit Scheibenbremsen (Standard)
Motor principal con freno de disco (de serie)
Motor principal com travão de disco (de série)

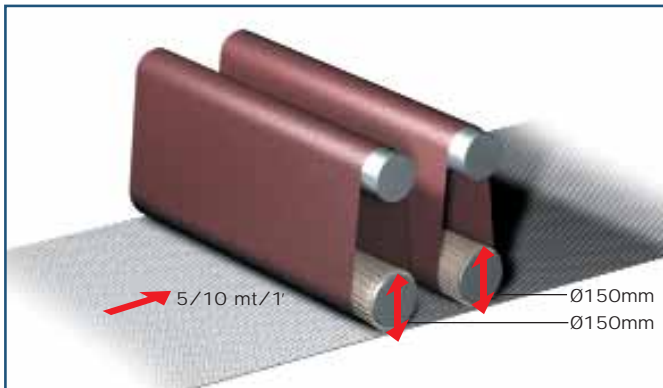

2W

2W600 - 2W950

Serie 40-04/A

Esecuzione macchina indicata per massiccio ed impiallacciatura:

- 2° rullo gommato 40° shore
- regolazione manuale in altezza del 1° rullo di contatto
- tampone morbido intercambiabile al tampone rigido di serie

Series 40-04/A

Execution of the machine suitable for solid wood and veneered surfaces with:

- 2nd roller rubber coated shore 40°
- manual height adjustment of the 1st contact roller;
- soft sanding pad in addition to the rigid ones

Série 40-04/A

Exécution de la machine pour bois massif et surfaces plaquées

- 2ème rouleau caoutchoute 40° shore
- réglage manuel en hauteur du 1er rouleau ;
- patin souple interchangeable avec le patin rigide pour massif

Baureihe 40-04/A

Maschinenausführung geeignet zum Kalibrieren und Schleifen von Massivholz und zum Schleifen von furnierten Oberflächen mit:

- 2 Kontaktwalze gummiert 40° Shore
- Handhöhenverstellung der 1. Kontaktwalze;
- Weichem Schleifschuh zusätzlich zum starren Schuh

Serie 40-04/A

Tipo de máquina indicada para macizo y chapa

- 2 rodillo engomado 40° Shore
- Regulación manual de la altura del primer rodillo de contacto
- Patin blando intercambiable con el patin rigido

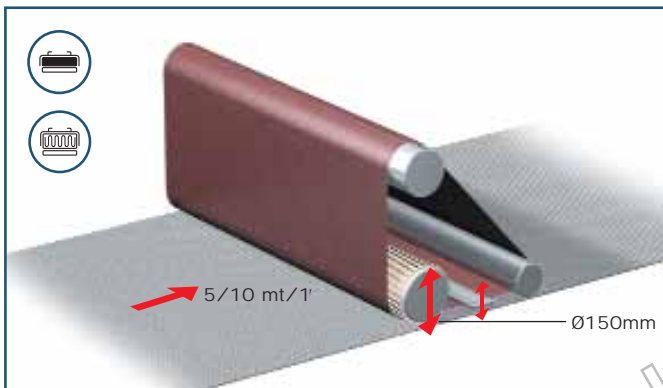

K

K600 - K950

Serie 40-04/A

Máquina indicada para trabalhar madeiras maciças e folheados:

- 2 rolo revestiolo a borracha 40 Shore
- Elevação manual do 1° rolo de contacto
- Patim macio em conjunto com patim rigido de série

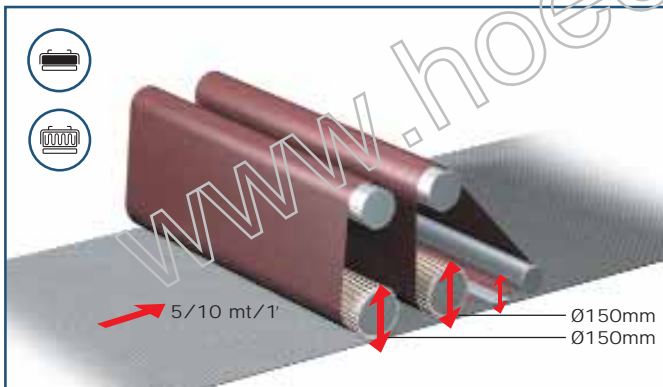

WK

WK950 - WK1100

Altri accessori - Other accessories - En options - Zubehören - Otros accesorios - Outros acessórios

- Motovariatore velocità avanzamento
- Aumento potenza motore principale

- Feed speed variator
- Increase of the main motor power

- Moto variateur vitesse d'entraînement ;
- Augmentation puissance du moteur principal ;

- Stufenloses Vorschubgetriebe;
- Erhöhung der Antriebsmotorstärke

- Motovariador de la velocidad de avance
- Aumento de la potencia del motor principal

- Variador de velocidade de avançamento
- Aumento de potência do motor principal

Dati tecnici - Technical data - Technische Daten Donnée techniques - Datos tecnicos - Dados tecnicos

DATI TECNICI GENERALI				
Larghezza max di lavoro	mm	600	950	1100
Passaggio max in altezza	mm	160	160	160
Passaggio min in altezza	mm	3	3	3
Sviluppo nastri abrasivi	mm	2150	2150	2150
Velocità nastri abrasivi	Mt/sec	18	18	18
Velocità avanzamento	Mt/min	5/10	5/10	5/10
Velocità variabile a richiesta	Mt/min	4-20	4-20	4-20
Potenza all'avanzamento	Hp	0,6/1,3	0,6/1,3	0,6/1,3
Potenza sollevamento piano	Hp	0,35	0,35	0,35
Potenza motore principale	Hp	7,5	7,5	10
Aumento potenza motore	Hp	richiesta	richiesta	richiesta

Dati tecnici soggetti a modificazioni senza preavviso

DONNEES TECHNIQUES				
Largeur maxi de travail	mm	600	950	1100
Passage en hauteur maxi	mm	160	160	160
Passage en hauteur mini	mm	3	3	3
Longueur des bandes abrasives	mm	2150	2150	2150
Vitesse des bandes abrasives	Mt/sec	18	18	18
Vitesse d'entraînement	Mt/min	5/10	5/10	5/10
Vitesse variable sur demande	Mt/min	4-20	4-20	4-20
Moteur entrainement	Hp	0,6/1,3	0,6/1,3	0,6/1,3
Moteur réglage table	Hp	0,35	0,35	0,35
Moteur principal	Hp	7,5	7,5	10
Augmentation puissance moteur	Hp	en option	en option	en option

Sous réserve de modifications des données techniques sans préavis

DATOS TECNICOS				
Anchura max de trabajo	mm	600	950	1100
Paso maximo de altura	mm	160	160	160
Paso minimo de altura	mm	3	3	3
Desarrollo banda abrasiva	mm	2150	2150	2150
Velocidad de la banda abrasiva	Mt/sec	18	18	18
Velocidad de avance	Mt/min	5/10	5/10	5/10
Velocidad avance variable (s.p.)	Mt/min	4-20	4-20	4-20
Potencia motor de avance	Hp	0,6/1,3	0,6/1,3	0,6/1,3
Potencia motor elevación mesa	Hp	0,35	0,35	0,35
Potencia motor principal	Hp	7,5	7,5	10
Aumento potencia motor principal	Hp	sobre pedido	sobre pedido	sobre pedido

Datos tecnicos sujetos a modificación sin previo aviso

TECHINICAL DATA				
Max working width	mm	600	950	1100
Max working height	mm	160	160	160
Min working height	mm	3	3	3
Lenght of the abrasive belts	mm	2150	2150	2150
Speed of the abrasive belts	Mt/sec	18	18	18
Feed speed upon	Mt/min	5/10	5/10	5/10
Variable feed speed upon request	Mt/min	4-20	4-20	4-20
Motor power for the feed speed	Hp	0,6/1,3	0,6/1,3	0,6/1,3
Motor power lifting table	Hp	0,35	0,35	0,35
Main motor power	Hp	7,5	7,5	10
Increased power of the main motor	Hp	upon request	upon request	upon request

Specifications and technical data subject to change without notice

TECHNISCHE DATEN				
Max Arbeitsbreite	mm	600	950	1100
Max Arbeitshöhe	mm	160	160	160
Min Arbeitshöhe	mm	3	3	3
Schleifbandlänge	mm	2150	2150	2150
Schleifbandgeschwindigkeit	Mps	18	18	18
Vorschubgeschw.	MpM	5/10	5/10	5/10
Stufenloser Vorschub auf Wunsch	MpM	4-20	4-20	4-20
Motorstärke am Vorschub	Hp	0,6/1,3	0,6/1,3	0,6/1,3
Motorstärke Tischverstellung	Hp	0,35	0,35	0,35
Antriebsmotorstärke	Hp	7,5	7,5	10
Stärkerer Antriebsmotor	Hp	Auf Wunsch	Auf Wunsch	Auf Wunsch

Technische Änderungen vorbehalten

DADOS TECNICOS				
Largura maxima de trabalho	mm	600	950	1100
Passagem máxima em altura	mm	160	160	160
Passagem mínima em altura	mm	3	3	3
Comprimento das cintas de lixa	mm	2150	2150	2150
Velocidade das cintas	Mt/sec	18	18	18
Velocidade de avan.	Mt/min	5/10	5/10	5/10
Velocidade variavel avan.	Mt/min	4-20	4-20	4-20
Motor de avançamento	Hp	0,6/1,3	0,6/1,3	0,6/1,3
Motor de elevação	Hp	0,35	0,35	0,35
Motor principal	Hp	7,5	7,5	10
Aumento potência motor	Hp	a pedido	a pedido	a pedido

Dados tecnicos sujetos a modificaciones sem preaviso



Sbf consult srl
Sede Amministrativa e Stabilimento:
Via Galvani, 10 - 36010 Zanè (VI) ITALY
Tel. 0445 314759 - Fax 0445 314785

www.sbfstefani.com
e-mail: info@sbfstefani.com
sbfcconsult@libero.it