

ACCORD 40 FX

ACCORD 40 FX CNC MACHINING CENTRE WITH MODULAR COMPOSITION



www.hoechsmann.com

accord 40 fx

NEW GENERATION
NEW SOLUTIONS





Solutions for every
production requirement



Innovation for each
component



The highest technology

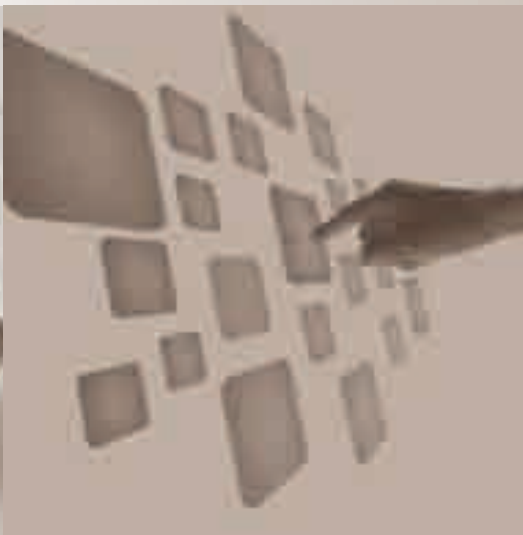
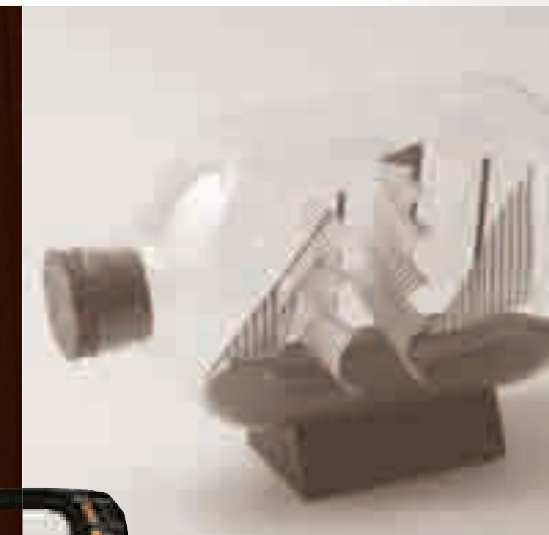



**Solutions for every
production requirement**

MAXI MACHINING UNIT

Compact machining unit with 3 or 5 interpolation axes specific for each type of use. The power of electrospindles SCM with HSK 63E tool holder ensures the use of big dimension tools with double profile. This characteristics guarantees high precision and finishing quality.

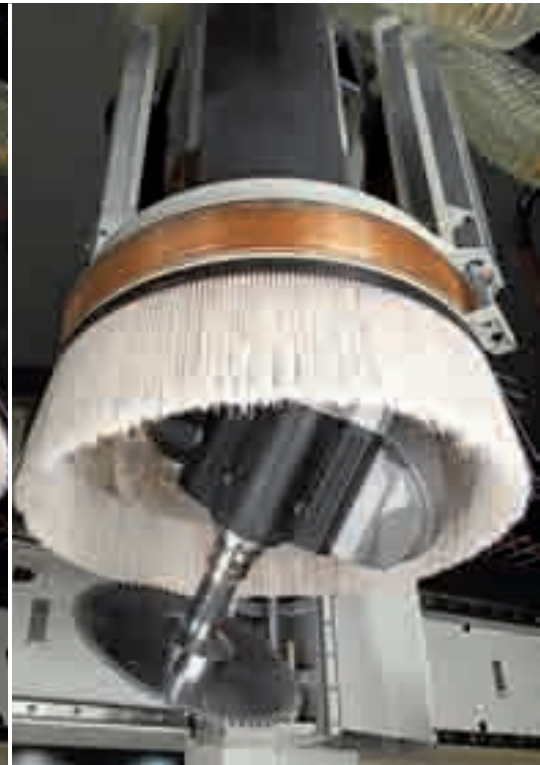

BRC working unit for door and windows: cutting, boring and routing, all the additional machining carried out with only one aggregate.

A wide range of boring units enables to increase the productivity and flexibility.

INNOVATION FOR EACH COMPONENT



Mach 5 is a device which controls the magazine in only 5 seconds (wood-wood), it replaces the tool of the eletrospindle reducing drastically the down-times of the machine.



A series of tool-holder magazines can contain up to 48 tools of big dimension to have the machine always operative for any use.



3 or 5 axes , tools with single or double threaded shaft. Accord Fx is equipped with a conveying making easier the chips and dust removal.



The highest technology

“MATIC” WORKING TABLE

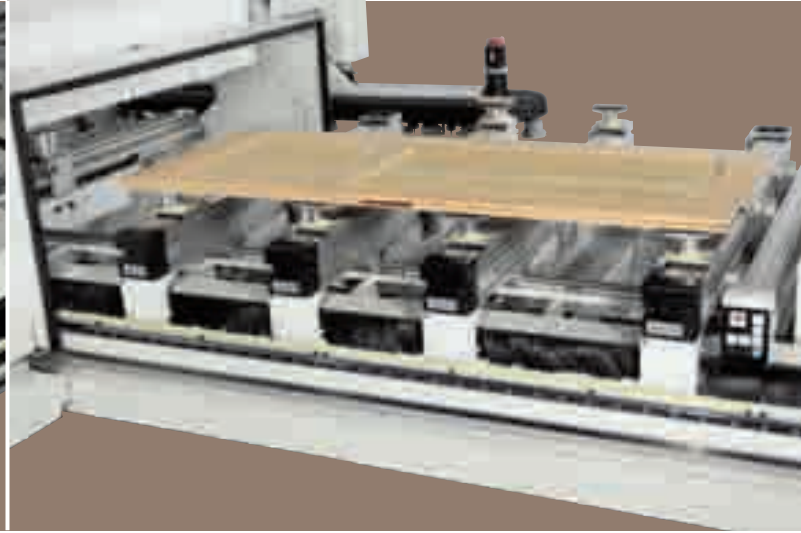
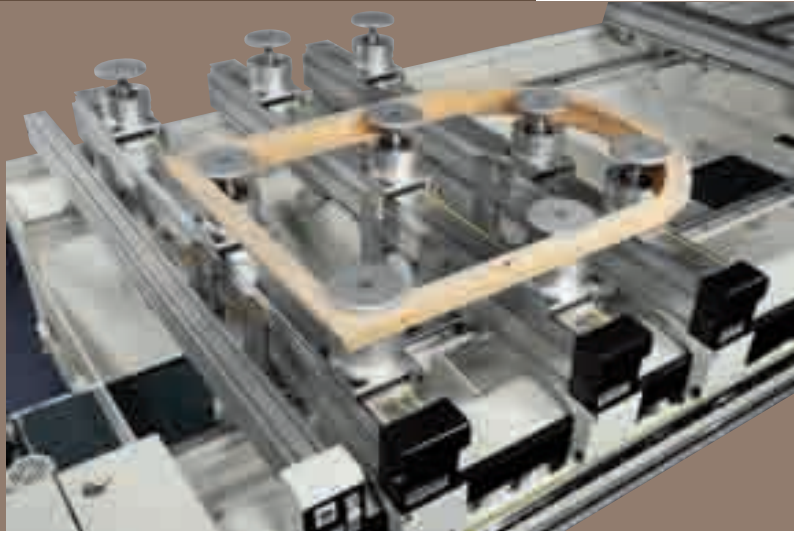

“Matic” is the working table Full Automatic of SCM for solid wood machining.

A motor for each bar, clamp or suction cup ensures a complete set-up in few seconds. The numerous technical improvements guarantee the machining with the plate safe and reliable for a long time.

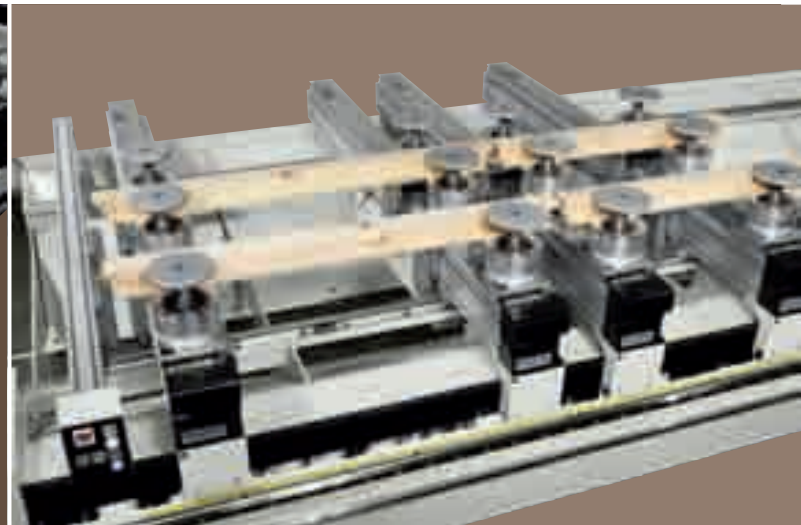

All the fixing supports are equipped with a cleaning system ideal for the machining of pre-finished doors and windows frames . The total control of the plate allows to the operator the easy and ergonomic loading and unloading of the pieces and to avoid any kind of collision.



Available not only with "Matic" version but also with "Pilot" guided version or "Start" manual, the plate ensures always a proper clamp to obtain the highest quality finish even with high rates of stock removal.

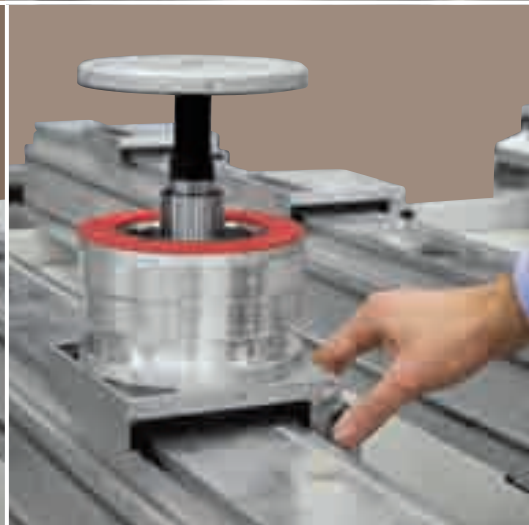
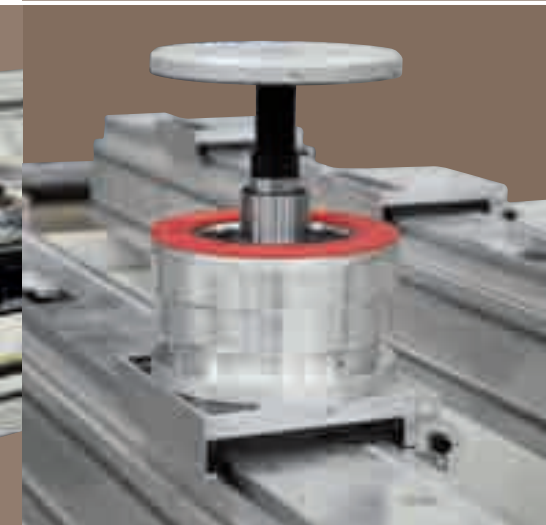

The exchange from the clamps to the suction cups is simply and quick. With the quick release system of SCM the operator replaces the pieces with no need to clamp or release tools.



Innovation for each component

SECURITY AND FREEDOM OF MOVEMENT

Security system composed of photoelectric cell and touch sensors. This solution foresees any kind of sensor into the floor to guarantee an easy accessibility to the machine and the possibility to utilize the total length of the plate for pendulum machining.

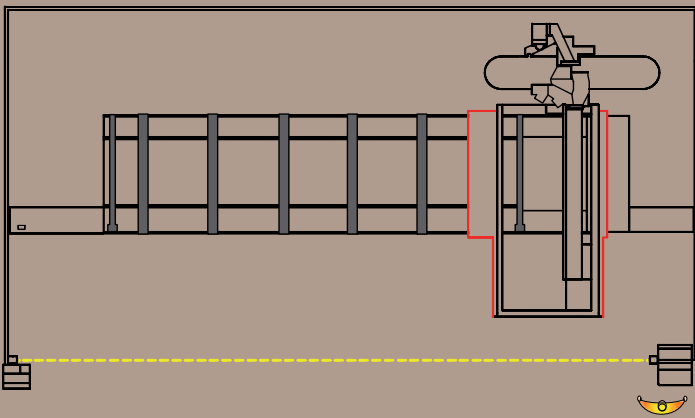

The loading area is delimited by a photoelectric cell preset to signal to the control system the further entrance of the operator to machine in total security.

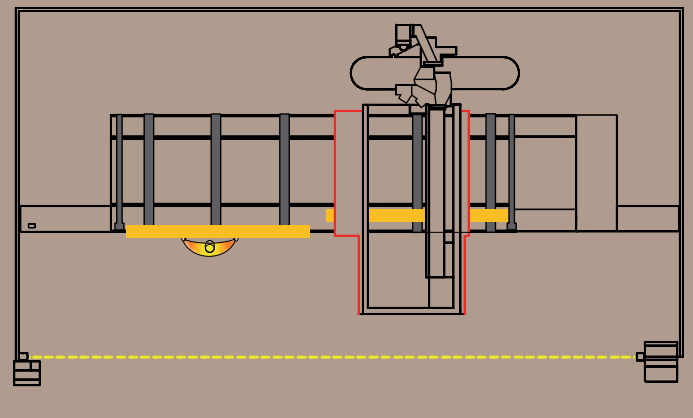

Sensors enable to the stop of the machine only in case of contact with a part in motion.

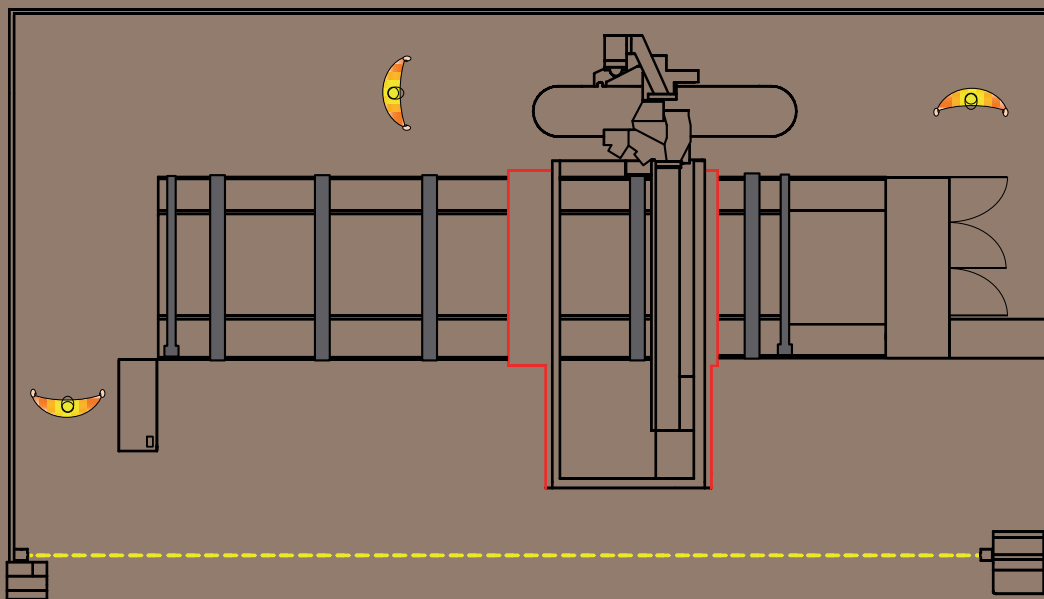

Entrance by the frontal side of the machine to reach the working area inside the perimeter barriers to reduce to the minimum the space engaged.

THE MODERN SOFTWARE TO SERVE THE CUSTOMER

Xilog Maestro

Operator interface with CAD/CAM integration allowing the easier machining of pieces with complex shapes.

A series of preset advanced functions enables also the operator not so much expert the:

- handling all machine functions
- programming and video-controlling the set-up of the working plate
- generation the data base of the tools
- programming with macro
- generation of a program list to execute in automatic

It is possible to integrate the functions with specific applications.



TELESOLVE

MANAGEMENT OF ERROR FLAGS

MANAGEMENT OF THE MALFUNCTIONING LOCALISATION

MANAGEMENT OF MACHINES PARAMETER

DIAGNOSIS AND UPDATING OF LOGIC "PLC"



scm group service

www.hoechsmann.com

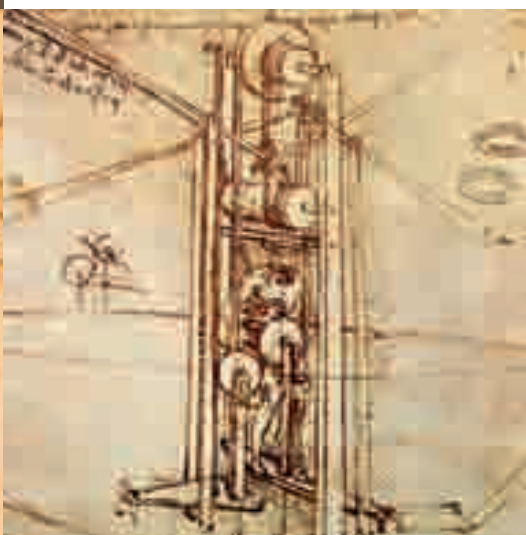
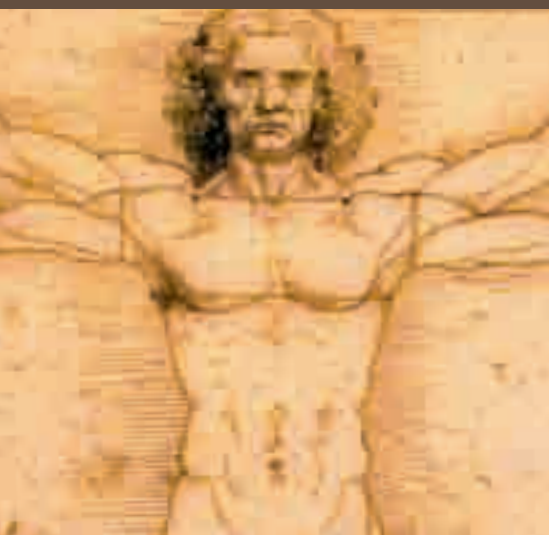

A leading industrial group, in the design, production and distribution of technologically advanced solutions for processing a wide range of materials: wood, glass, plastic, marble, metal, composites.

With specialist brands in the different application sectors and centres of excellence qualified in industrial components, present for over 50 years in the 5 continents.

PASSION. It's the passion for our work. It's the central role of man, his creative genius, the spirit of initiative and the ability to work in a team.

TECHNOLOGY. Is the scientific rigour that transforms creativity in highly technological solutions, which are accessible and able to provide competitive advantages.

PERFORMANCE. Is the commitment that is transformed in results and success of our partners that rely on SCM Group solutions. It's being recognised as suppliers of "competitive advantages that last over time".

THE BEST GLOBAL PARTNER FOR THE WOODWORKING COMPANIES



Since 1952 Scm supports the small woodworking companies and the manufacturers of made-to-measure furniture by means of user-friendly and innovative technological solutions, distributed by the

world's best sales network, constantly trained and updated in order to offer on local basis a global competence to the advantage of woodworking companies.

SINCERT



The technical data can vary according to the requested machine composition. In this catalogue, machines are shown with options. The company reserves the right to modify technical specifications without prior notice; the modifications do not influence the safety foreseen by the CE Norms.

www.hoechsmann.com



00L0029963G

Rev. n. 01 - 07/2011 - Acanto comunicazione - Olimpia



SCM GROUP SpA - SCM - Via Casale, 450 - 47826 Villa Verucchio (RN) - Italy
Tel. +39/0541/674111 - Fax +39/0541/674235 - www.scmgroup.com - housing@scmgroup.com

www.hoechsmann.com