

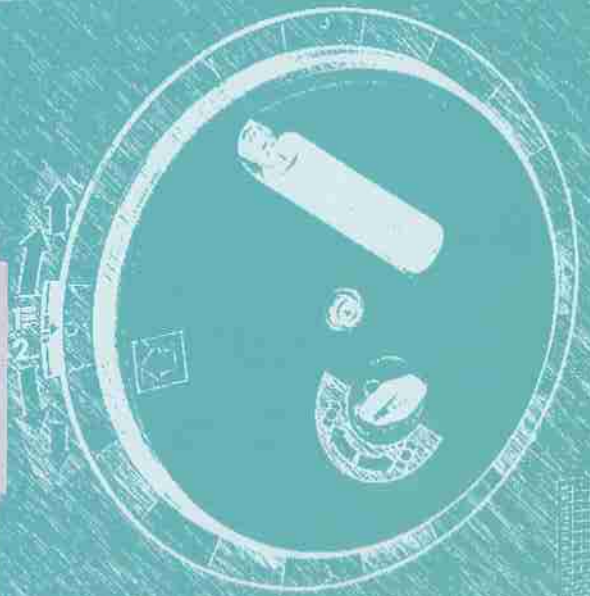

# F 330

## TOP MASTER



## TOP MASTER



# Toupie verticali ed inclinabili

# F

Starre und schwenkbare Fräse  
Fixed and tilting vertical spindle moulder  
Toupies verticales et inclinables  
Tupis vertical y inclinable

**Prestazioni  
da primo piano**

Erstklassige Leistungen  
First class performance  
Rendement de premiere qualité  
Prestaciones de primera calidad



- ALBERO INTERCAMBIABILE MK4
- Auswechselbare Spindel MK4
- Interchangeable spindle MK4
- Arbre interchangeable MK4
- Eje intercambiable MK4



- CUFFIA TOUPIE PER SAGOMARE - STANDARD PER VERSIONE CE
- Fräsehaube zum Fassonieren - Serienausstattung für CE Ausführung
- Moulding spindle protection - standard for CE version
- Protection toupie pour façonner - standard pour machine CE
- Casquillo tupi para perfilar - standard para version CE



- FOTO DELLA MACCHINA IN VERSIONE STANDARD NON CE.
- Abgebildetes Modell in Serienausstattung.
- Picture of the machine in standard version.
- Photo de la machine en version standard.
- Foto de la máquina versión no CE.

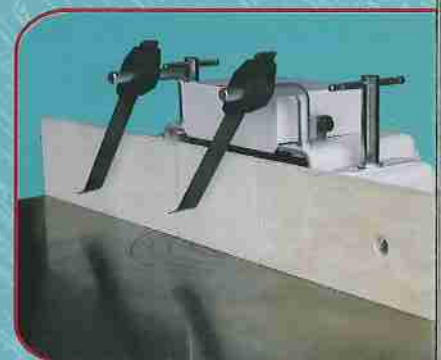

- **OPTIONAL:** GUIDA TOUPIE CON INDICATORE NUMERICO
- **Zubehör:** Drehbarer und einstellbarer Anschlag mit mechanischer Anschlagmechanik
- **Optional:** spindle moulder fence with mechanical indicator
- **Accessoire:** guide toupie réglable à compteur numérique
- **Opcional:** guía tupi con indicadore numérico



# 330

**OPTIONAL:** CARRO A TENONARE LATERALE CON CUFFIA DI PROTEZIONE PER TENONARE

**Zubehör:** Schwere Zapfenschneidisch mit Absaughaube

**Option:** Lateral tenoning sliding table with tenoning guard hood

**Accessoire:** Chariot à tenonner latéral avec hotte de protection à tenonner

**Opcional:** Carro a espigar lateral con casquillo de protección para espigar

- FOTO DELLA MACCHINA CONFORME ALLE NORME CE.
- Abgebildetes Modell in EG-Ausstattung.
- Picture of the machine in CE version.
- Photo de la machine conforme aux normes CE.
- Foto de la máquina conforme a normas CE.



**NUMERICO**  
mit mechanisch-numerischen Anzeigen  
mechanical readout  
mécanique numérique

- **OPTIONAL:** SUPPORTO RIBALTABILE PER TRASCINATORE
- **Zubehör:** Varschub mit neigbarer Auflage
- **Optional:** Feeder with tilting support
- **Accessoire:** Entraînement avec support inclinable
- **Opcional:** Soporte volquete para arrastrador

## F 330i

toupie inclinabile  
Schwenkspindelfräse  
tilting spindle moulder  
toupie inclinable  
tupi inclinabile





DATI TECNICI		F 330	F 330i
Dimensioni piano fisso	mm	1100x750	1100x920
Altezza del piano di lavoro	mm	920	920
Ø max apertura sul piano	mm	330	330
Ø max utile a profilare (CE)	mm	220	220
Ø albero toupie	mm	30	30
Corsa verticale albero	mm	220	220
Velocità albero	g/l'	2500-4200-6000-8000-10000	2500-4200-6000-8000-10000
Potenza motore	Kw (HP)	5,5 (7,5)	5,5 (7,5)
Bocca aspirazione inferiore Ø	mm	120	120
Bocca aspirazione guida Ø	mm	120	120
Inclinazione albero		-	-5° +45°



TECHNISCHE DATEN		F 330	F 330i
Abmessungen des festen Tisches	mm	1100x750	1100x920
Arbeitsstischhöhe	mm	920	920
Ø Max. auf dem Tisch	mm	330	330
Ø Max. Werkzeuge um Fassonieren	mm	220	220
Ø Frässpindel	mm	30	30
Frässpindelhub	mm	220	220
Drehzahlen	g/l'	2500-4200-6000-8000-10000	2500-4200-6000-8000-10000
Motorstärke	Kw (HP)	5,5 (7,5)	5,5 (7,5)
Untere Absaugungshaube Ø	mm	120	120
Absaugungshaube des Fräsanschlag Ø	mm	120	120
Schwenkung der Spindel		-	-5° +45°



TECHNICAL DATA		F 330	F 330i
Size of fixed table	mm	1100x750	1100x920
Height of working table	mm	920	920
Ø max of table opening	mm	330	330
Ø max tool for spindle fence	mm	220	220
Ø spindle shaft	mm	30	30
Spindle up stroke	mm	220	220
Motor power	g/l'	2500-4200-6000-8000-10000	2500-4200-6000-8000-10000
Potenza motore	Kw (HP)	5,5 (7,5)	5,5 (7,5)
Bottom suction hood Ø	mm	120	120
Suction hood of the fence Ø	mm	120	120
Tilting spindle shaft		-	-5° +45°



DONNEE TECHNIQUES		F 330	F 330i
Dimensions du table fixe	mm	1100x750	1100x920
Hauteur de plan du travail	mm	920	920
Ø max sur la table	mm	330	330
Ø max outil pour guide toupie	mm	220	220
Ø arbre toupie	mm	30	30
Course verticale du arbre	mm	220	220
Vitesse arbre	g/l'	2500-4200-6000-8000-10000	2500-4200-6000-8000-10000
Puissance moteur	Kw (HP)	5,5 (7,5)	5,5 (7,5)
Hotte d'aspiration inférieure Ø	mm	120	120
Hotte d'aspiration pour la guide toupie Ø	mm	120	120
Inclinaison de l'arbre		-	-5° +45°



DATOS TECNICOS		F 330	F 330i
Dimensiones mesa	mm	1100x750	1100x920
Altura mesa de trabajo	mm	920	920
Ø max apertura en la mesa	mm	330	330
Ø max herramientas en la guía (CE)	mm	220	220
Ø eje tupi	mm	30	30
Recorrido vertical del eje	mm	220	220
Velocidades eje	g/l'	2500-4200-6000-8000-10000	2500-4200-6000-8000-10000
Potencia motor	Kw (HP)	5,5 (7,5)	5,5 (7,5)
Colector de viruta inferior Ø	mm	120	120
Colector de viruta de la guía Ø	mm	120	120
Eje inclinable		-	-5° +45°

## F 330

- PESO NETTO
- Nettogewicht
- Net weight
- Poids net
- Peso neto

**Kg 560**

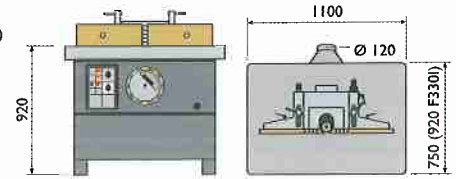

## F 330 L

- PESO NETTO
- Nettogewicht
- Net weight
- Poids net
- Peso neto

**Kg 650**

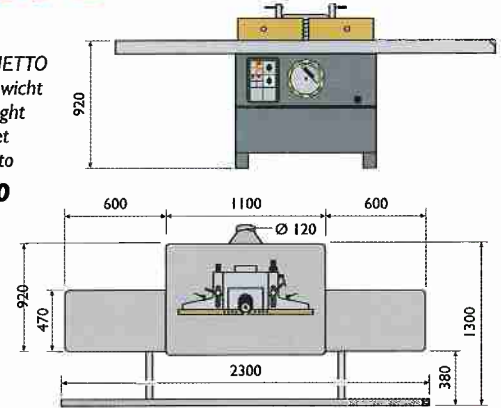

## F 330 T

- PESO NETTO
- Nettogewicht
- Net weight
- Poids net
- Peso neto

**Kg 670**

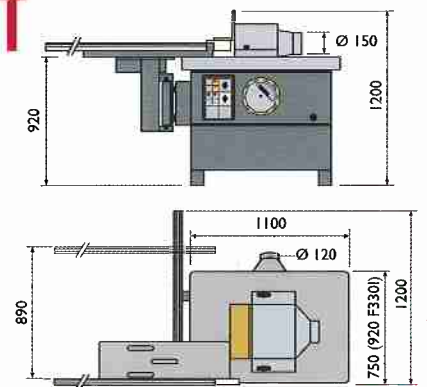

## F 330 TL

- PESO NETTO
- Nettogewicht
- Net weight
- Poids net
- Peso neto

**Kg 720**

