

# **CNC-Machining Centers** **Optimat BHC 750/850** **profi line BHC 700/800**

Efficiency In Action!

**Optimat**  
**profi line**

# Optimat BHC 750/850

## The Perfect All Around Machine

The Optimat BHC 750, with all of its diverse configuration possibilities, is a highly effective solution to your requirements. Whether your business is in store fixtures, solid wood machining, door, window, stair and office furniture manufacturing or exhibit stand manufacturing, the BHC 750 is equipped for all of your demands.

With a history of over 50 years, Weeke has amassed an extensive array of application knowledge in every area of woodworking and flat panel processing. This experience is the foundation for the various configurations which are available to you in our Optimat Range.

- detailed and all around capability
- intelligent and established software,
- friendly, fast and competent service
- a state-of-the art training center and an outstanding Show Room give Weeke capabilities that can further assist you

Come and be convinced! See the latest that WEEKE has to offer!

**WEEKE – your partner  
for the future.**  
Member of the  
**HOMAG-Group.**  
Certified by  
**DIN EN ISO 9001**



**Optimat BHC 750**  
with K-Table



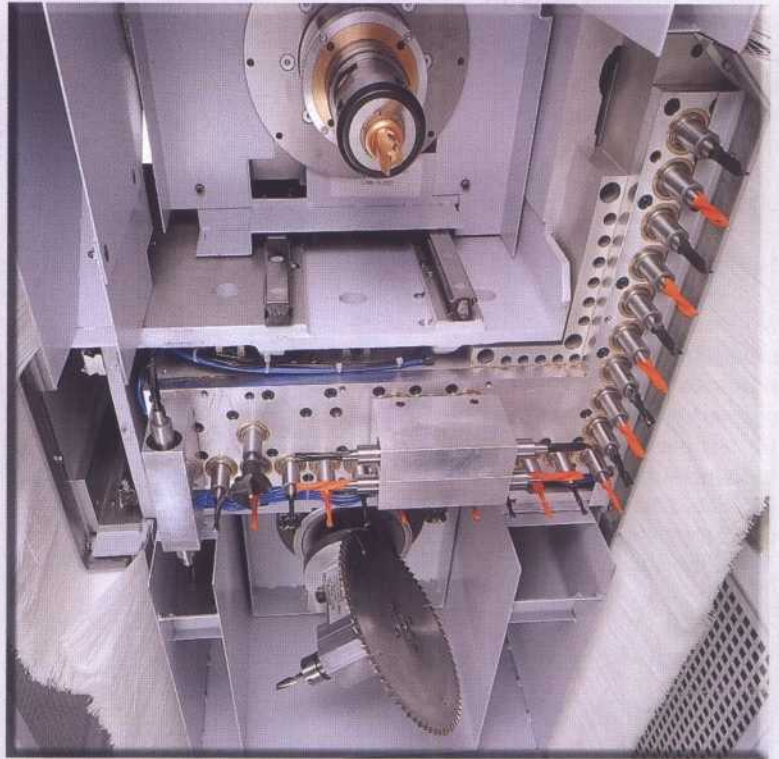

Typical machining head configuration

Photos may show optional items

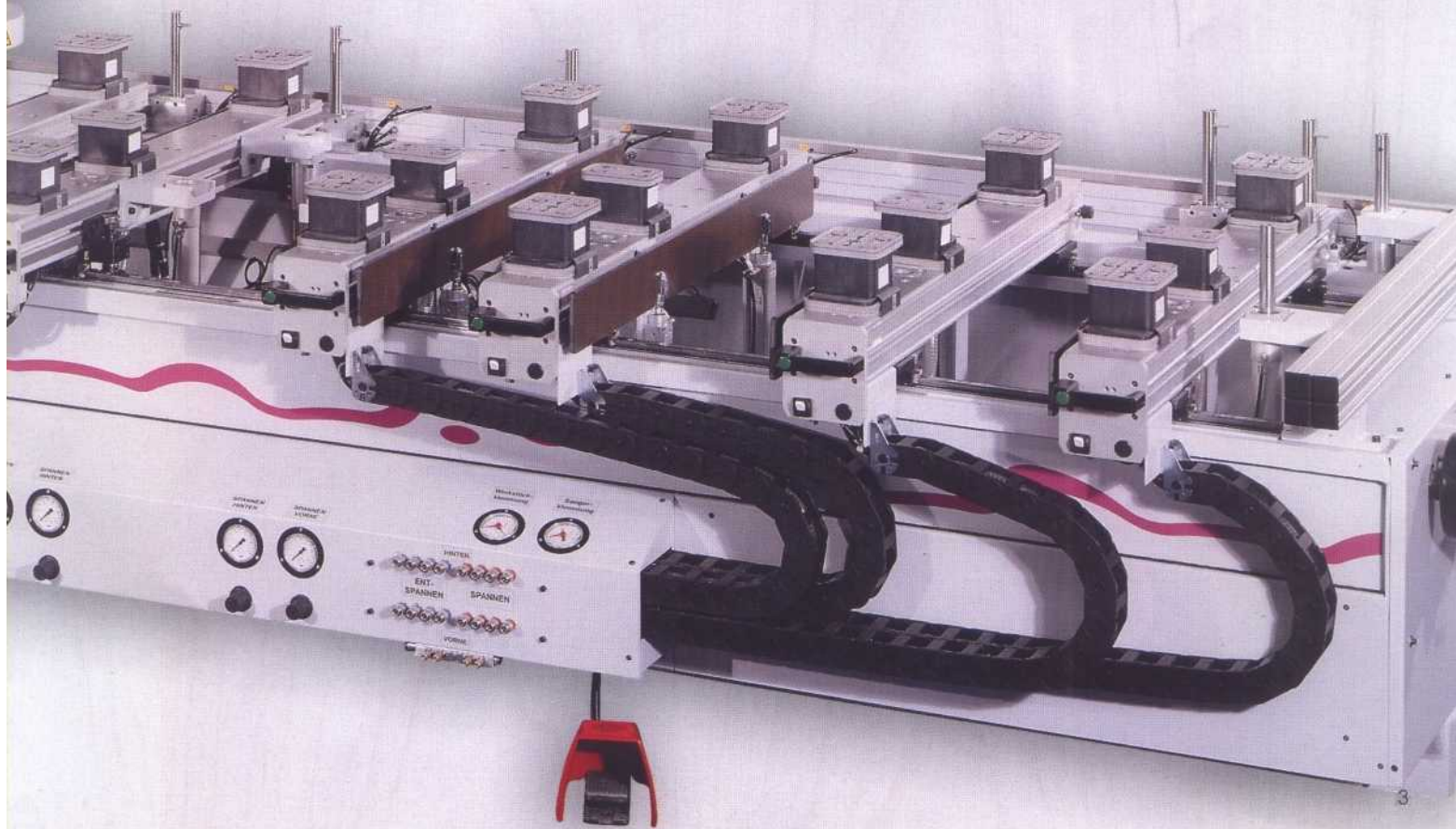

# profi line BHC 700/800

## Complex capabilities at the highest level

With our profi line BHC 700/800 we offer you some of the most technically advanced CNC solutions available. The ability to adapt to all customer demands is enabled by our modular construction system. All the advantages of our BHC 750/850 Optimat Range can be found in the designs of the profi line series.

Double-sided machining, with up to 4 Y-axes, provides heavy emphasis on extensive drilling and routing capabilities. These, along with automatic tool changing in the background, are some of the highlights of these machining centers. All individual machining processes (drilling, sawing, routing) are integrated at the highest levels of productivity!



*Possible machining head configuration*



*Possible machining head configuration*

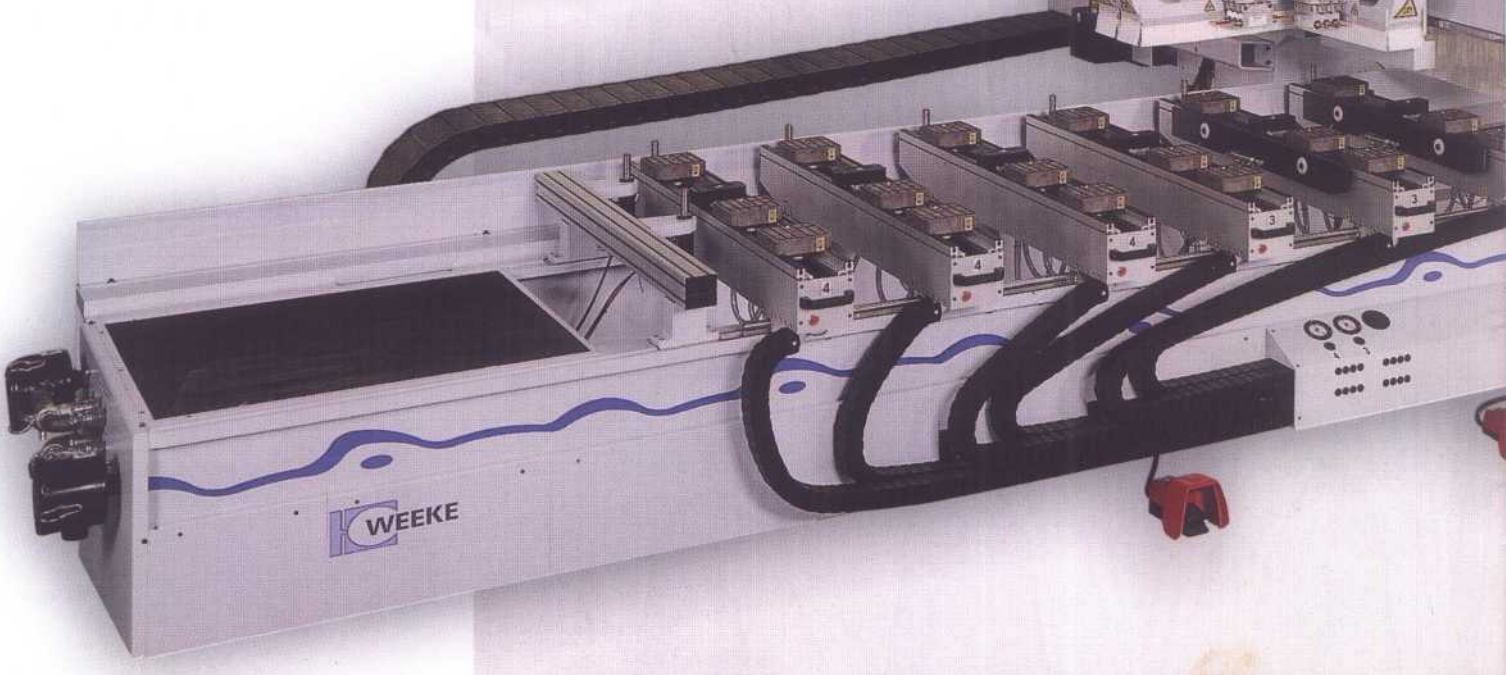

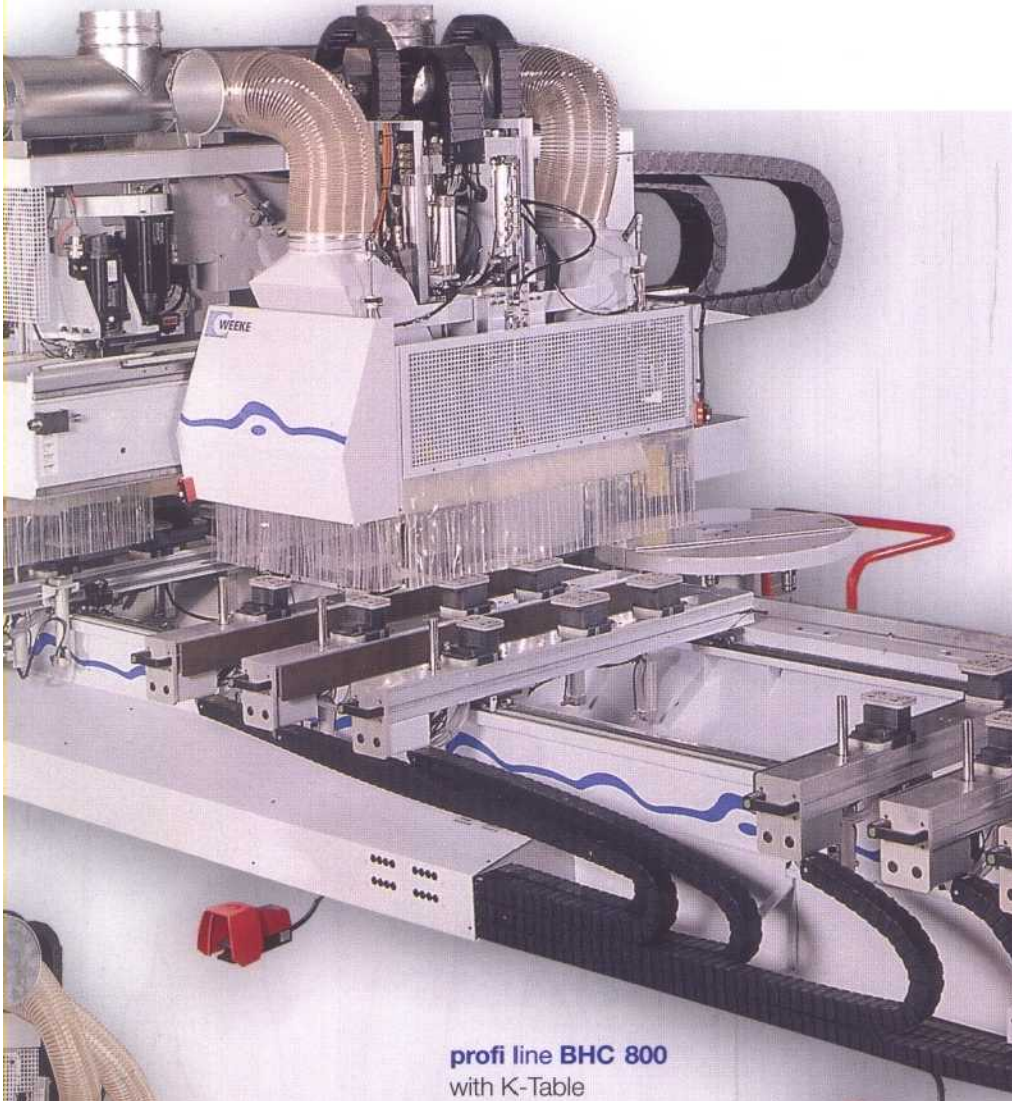

**profi line BHC 800**  
with K-Table

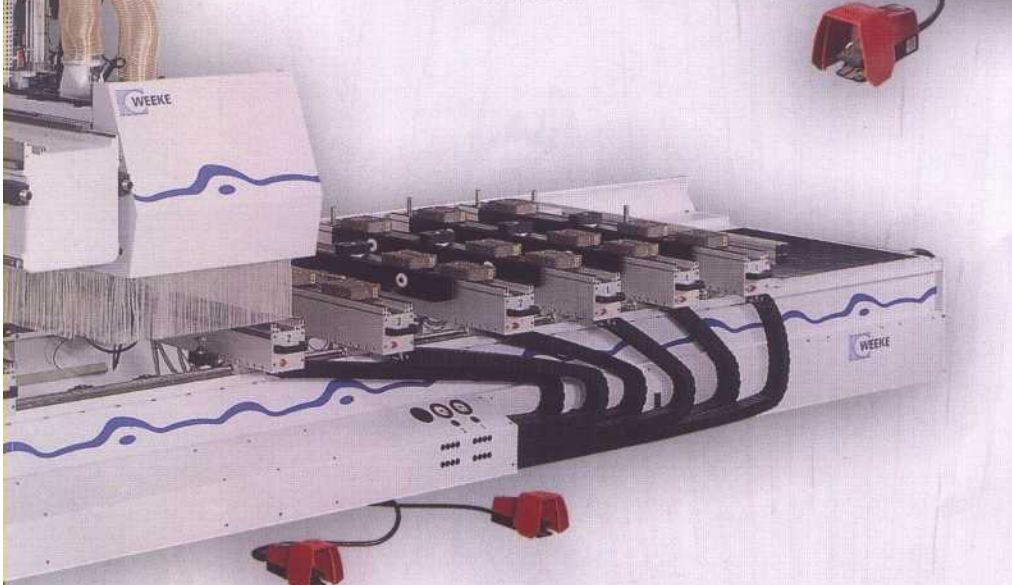

**profi line BHC 800**  
with Standard-Table



*Possible machining head configuration*

Combined with our extensive aggregate technology, this **series offers an optimal and highly flexible solution for all types of industry.**

Regarding clamping or machining head configurations, you have endless possibilities to realize your specific requirements with our **profi line** range. The success of our prior projects has shown the market that WEEKE has incredible capabilities to offer!

Please challenge us! You will be amazed at what we can do for you!

# profi line BHT 320 and profi line BHT 800

What other technological advancements would you like to see?

## profi line BHT 320

- CNC controlled machining center with throughfeed design
- low-price introduction into machinery automation
- up to 2 workpieces can be transported into the machine
- 2 independent machining supports are available for machining of panels
- integration as a stand-alone machine or into an automatic machine line
- vast range of machining and assembly aggregates
- high speed positioning and machining
- extremely economic price performance ratio



## profi line BHT 800

With our BHT 800 machine, WEEKE offers you the possibility to process complex workpieces in integrated machine lines. This machine concept unites the advantages of our CNC-controlled machining centers with our highly efficient Throughfeed Drilling Machines. The workpieces are processed in a single clamping step.

- CNC controlled machining center with throughfeed design
- infeed transport and part alignment within approx. 3 seconds
- the machine can process the workpiece from 4 sides
- 2 workpieces with a width of 500 mm can be processed at the same time

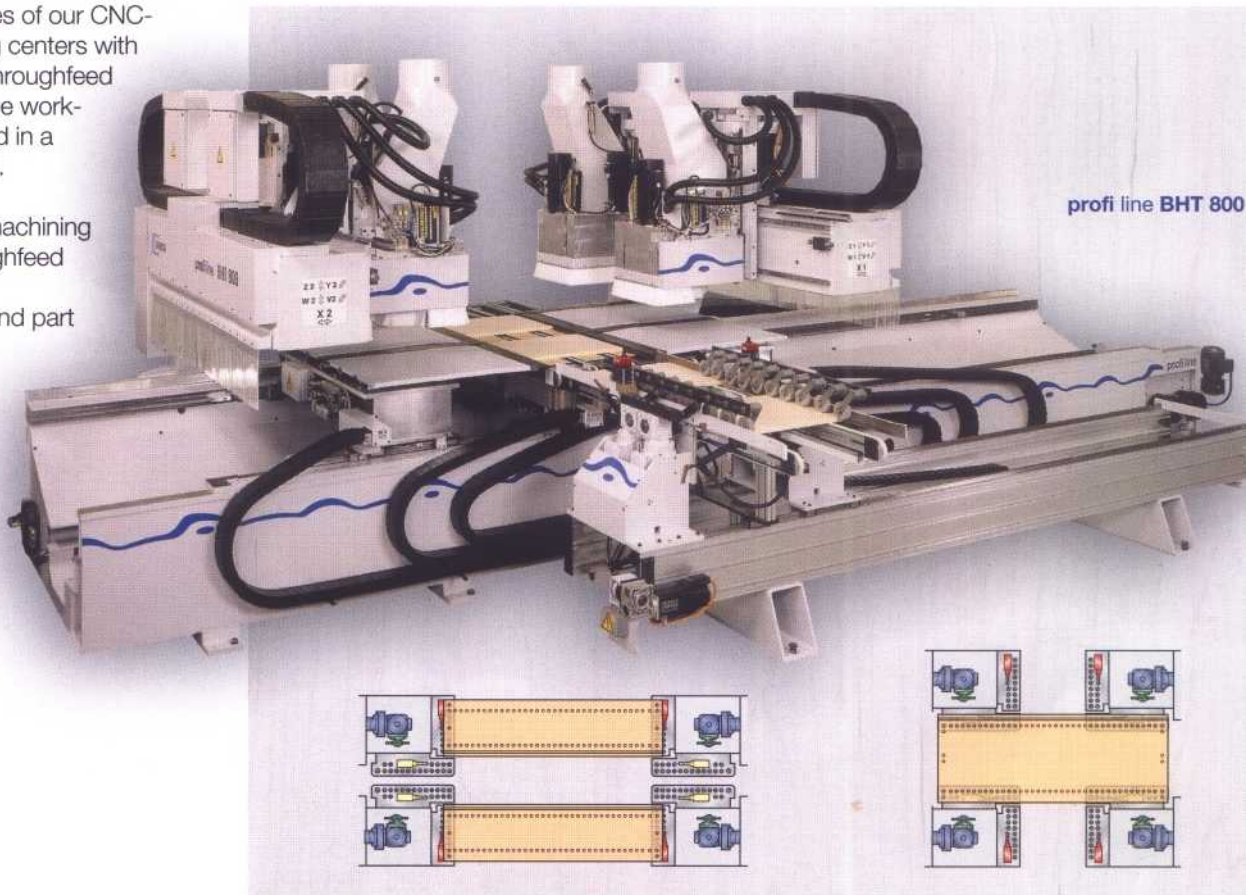

# Our table configurations

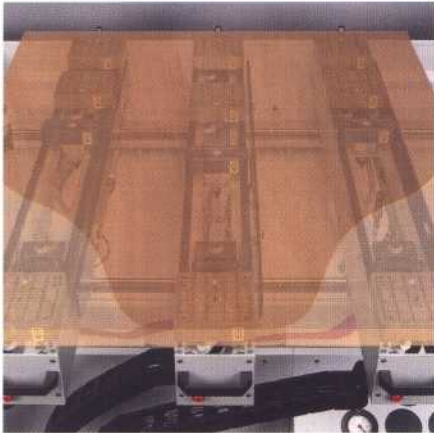

Back stops for positioning of gauges

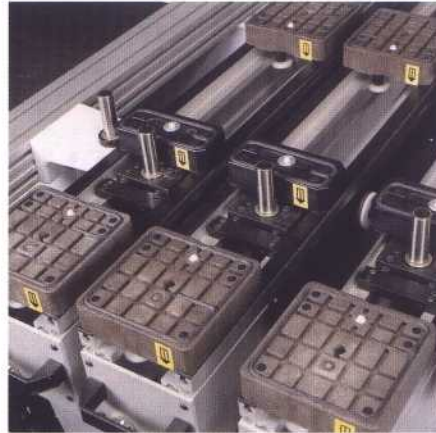

Front stops for positioning of workpieces

Clamping of the workpieces is one of the most important criteria for the quality of CNC machining. WEEKE offer you 3 distinct possibilities for this critical process. Additionally, the profi line range offers you additional capabilities to realize your specific requests.

## Basic-Table

- laser positioning for vacuum pods
- panel feeding rails
- rear back stop row
- solid clamping system

## Matrix-Table

- positioning of a panel without pre-sizing
- optimised nesting of component parts
- single piece acrylic machining
- laser positioning for vacuum pods

## K-Table

- tubeless vacuum pod system
- powerful vacuum pump
- crosshair laser for vacuum pod positioning
- pneumatic clamping system for rail and frame components
- replaceable gasket covers for vacuum pods
- up to 8 vacuum pods per bench support
- panel feeding rails

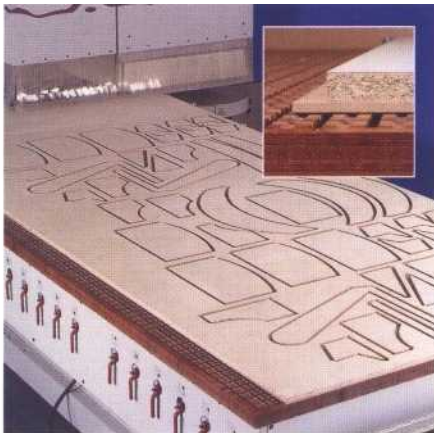

Non-rectangular shaped parts in a nested sheet



Door manufacturing with the NBM concept

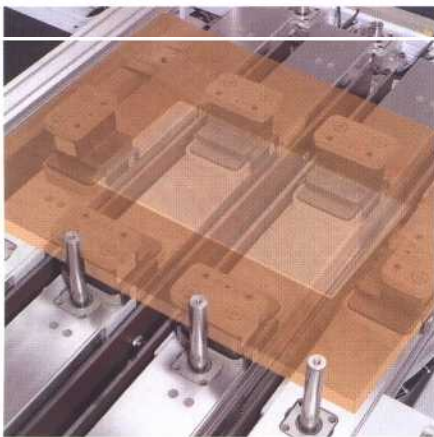

Vacuum pods length- and crosswise

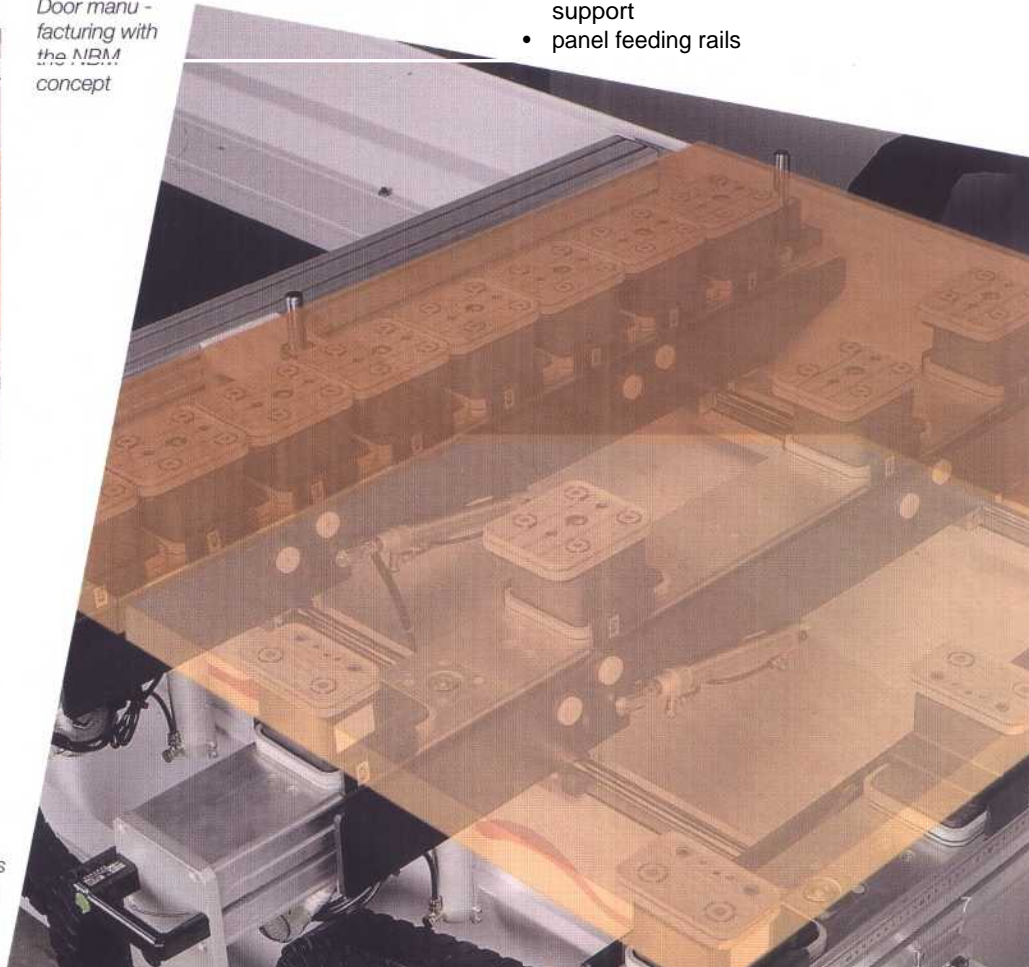

Up to 8 vacuum pods on one bench

E  
0  
0  
a  
E  
0  
a

# Line configuration possibilities from our profi line BHC 700/BHC 800 Range

Our designs are determined by your requirements

So you say you need a lot of production in the shortest possible time. Naturally, the parts must be processed with quality and precise detail. This is a typical requirement which many customers demand.

Here you can see many different possibilities of how to utilize our machining centers, combined with several different feeding options (e.g. via robot). With these and many other configurations, you can successfully fulfill your production requirements in a highly profitable manner.

Take advantage of WEEKE as your experienced partner for optimizing your production!

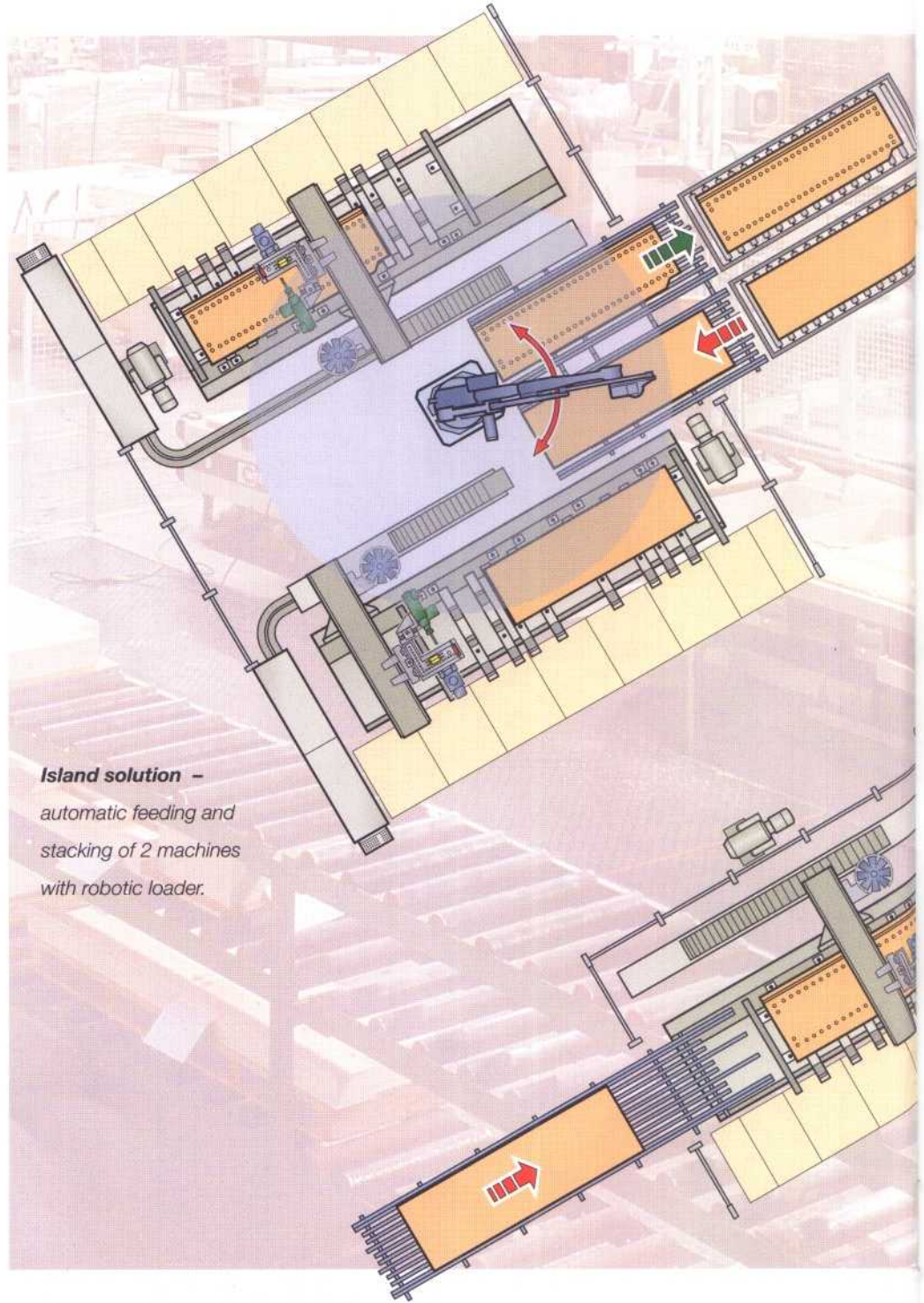

*Island solution – automatic feeding and stacking of 2 machines with robotic loader.*

*Island solution – (side view)*

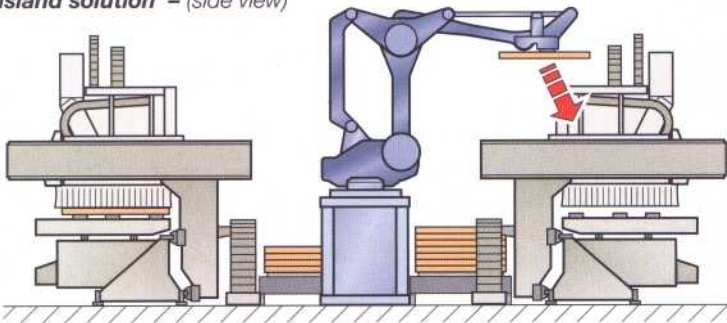

*Machining Center in a production line as a separate machining unit (side view)*

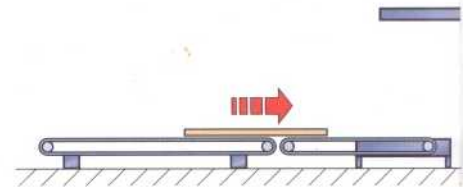



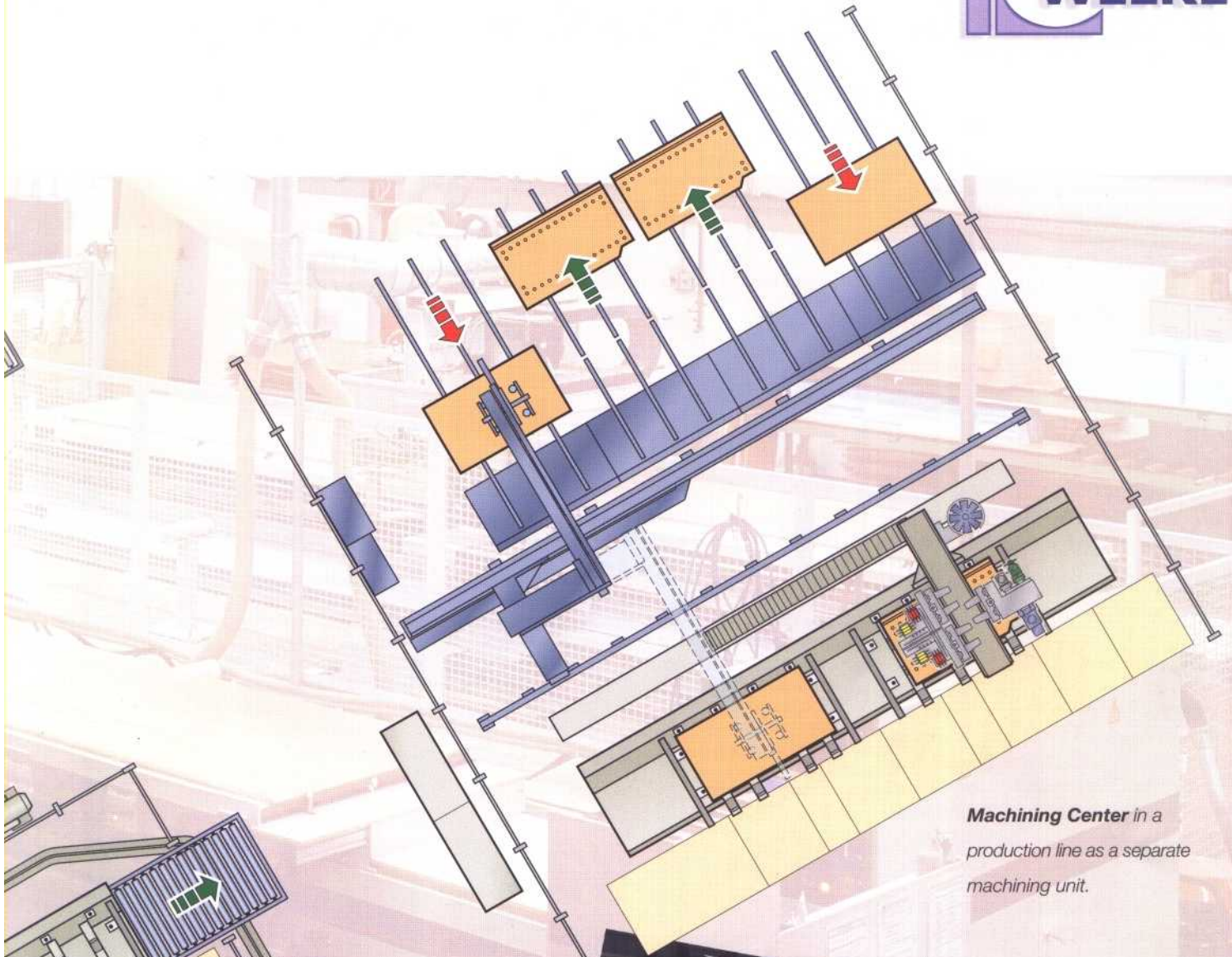

**Machining Center** in a production line as a separate machining unit.

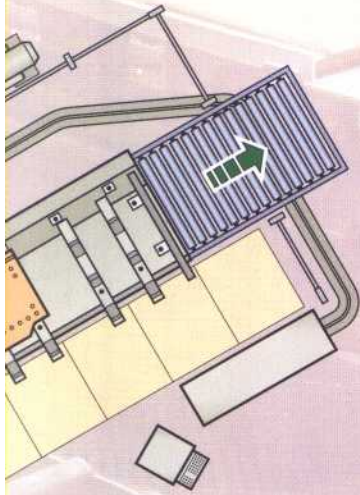

**Machining Center** in a production line with automatic panel transport and throughfeed design.

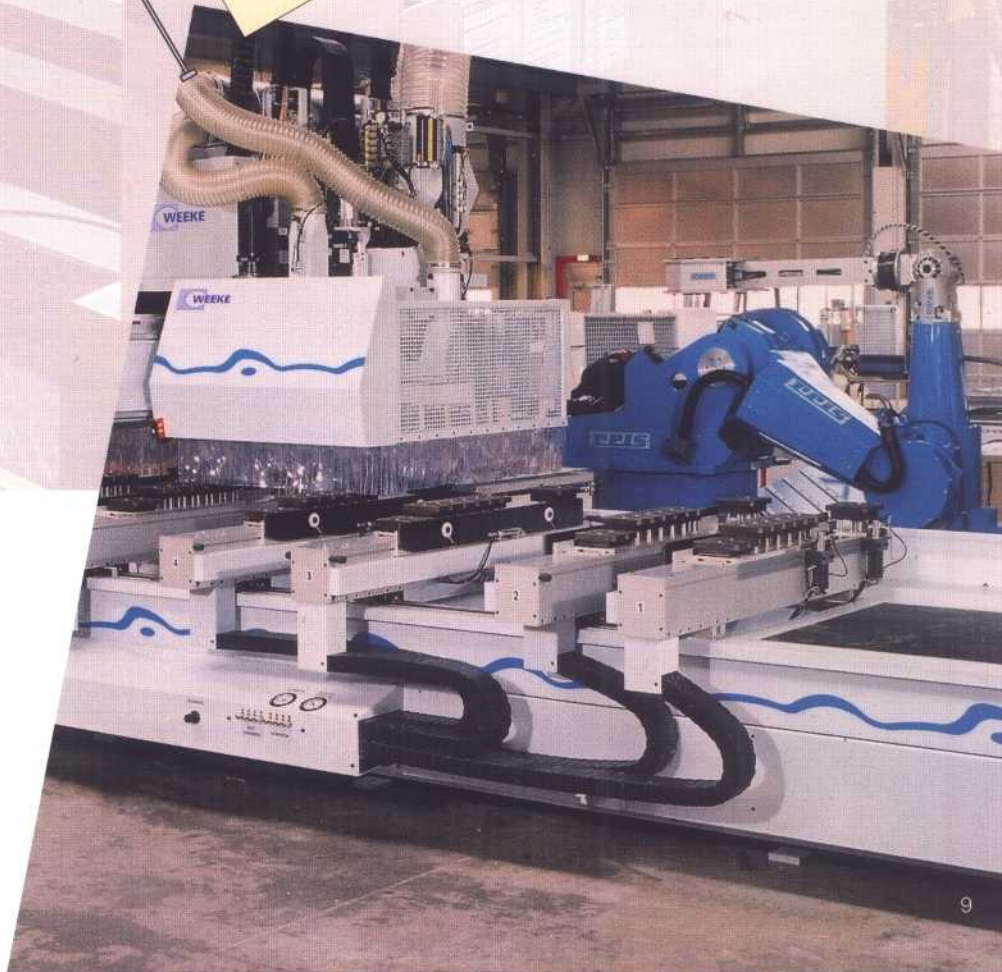
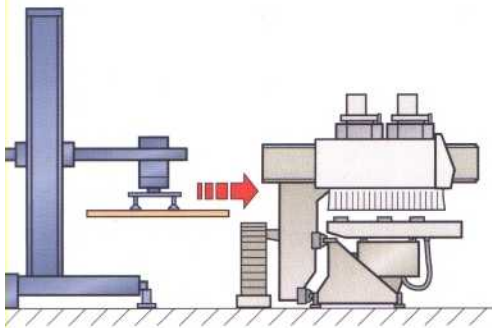

# Our aggregate versatility insures maximum flexibility for your production needs.

You do not have to know the future when you purchase a WEEKE machine. We offer you a flexible solution which is open and which can adapt to the future demands of the market.

## The C-axis

- fast and accurate positioning of the aggregates
- HSK 63-tooling interface
- three locating guide pins

### Advantages:

- higher product quality
- longer tooling life

Full programming capability of the aggregates from 0°-360° degrees.

## The pneumatic interface

A programmable air line to the aggregate is necessary for applications such as deep horizontal pocket routing or a floating head. Weeke provides this as a standard for these applications and more, insuring the quality output that you require.

Precisely like the profi line BHC 700/800 the Optimat BHC 750/850 is equipped with a highly efficient HSK 63 routing spindle and at least one automatic tool changer.



**Horizontal Drilling, Routing and Sawing**

*For horizontal drilling, routing and sawing of grooves, hardware connections, and through cuts etc. under any angle (0°-360°) Max saw blade diam. 240 mm.*



**Horizontal Routing Aggregate**

*For horizontal drilling and routing up to a depth of 50 mm under any angle (0°-360°).*



**Cam Box Routing Aggregate**

*For cam box routing, hinge slots and horizontal routing up to a depth of 128 mm (0°-360°). Available with one or two spindles per side.*



**Drilling/Sawing Inclinable**

*For drilling and sawing up to a depth of 50 mm under any angle (0°-360°). The angle of the drill or the saw blade can be adjusted manually (0°-90°).*



**Sanding Aggregate**

*For sanding of MDF or solid wood edges. An air nozzle continuously cleans the sanding tool.*



**Gang Drilling Aggregate**

*For row hole drilling under any angle (0°-360°). Possible center distances of 25, 30 or 32 mm.*



**Corner Notching Aggregate**

*For sharp-corner notching of material with thickness of 25 - 60 mm under any angle (0°-360°).*



**Underfloor Aggregate**

*For vertical routing or drilling on the bottom side of the workpiece. Routing is possible within 100mm of the edge of the workpiece at any angle (0°-360°).*

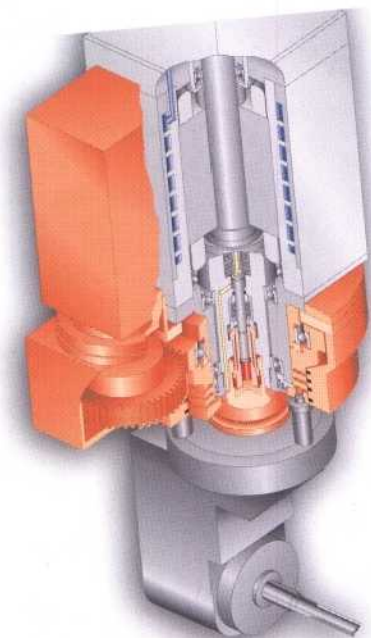

## Liquid cooling system

- constant temperature even at high rpm and heavy routing. no heat build-up at the bearings = high reliability
- electronic sensors = long life

## HSK tool interface

- for fast cutting speeds and the most stable clamping design
- large area between routing spindle and HSK-tool
- extreme draw-bar strengths (11 kN)



**Drilling/Routing Inclinable**

For drilling (pictured) and routing up to a depth of 78 mm under any angle (0°-360°). The angle of the drill or router bit can be adjusted manually (0°-90°).

**Drilling/Routing Inclinable**

For drilling and routing (pictured) up to a depth of 78 mm under any angle (0°-360°). The angle of the drill or router bit can be adjusted manually (0°-90°).

**Horizontal Routing Aggregate**

2 spindles (clockwise/counter-clockwise operation). For horizontal drilling and routing up to a depth of 50 mm under any angle (0°-360°).

**Vertical Routing with Tracer Shoe**

For routing in the workpiece surface, for routing of profiles or for tongue and groove joints, with C-axis controlled tracer shoe. The integrated air nozzle removes the chips. (0°-360°).

**Vertical Routing with Tracing Ring**

For routing in the workpiece surface, for routing of profiles or for tongue and groove joints. The complete surface of the tracing ring rides on the workpiece. The integrated air nozzle removes the chips. (0°-360°).

**Vertical routing with tracing ring**

For routing in the workpiece surface, for routing of profiles or for tongue and groove joints. The complete surface of the tracing ring rides on the workpiece. The integrated air nozzle removes the chips.



**Routing Aggregate with Chip Extraction Device**

For vertical routing with a high amount of chips, heavy routing and profiling - a spiral leads the chips directly into the dust extraction (0°-360°).

**Planing Aggregate**

For surface planing applications up to 100 mm wide, (e.g. grooving or V-grooving) but also for applications with decorative moulding cuts.

**Horizontal Routing Aggregate**

Horizontal routing spindle for flush milling of glued edges on a soft- or postformed profile.

**High-Speed Routing aggregate**

Spindle Speeds Up to 30,000 rpm. For simple operations with small tool diameters, e.g. engraving processes, routing in plexi-glass.

**Thread Cutting Aggregate**

For cutting of threads (from M4 to M12) in plastics.

**Flush Trimming Aggregate**

3-sided tracing, allowing for workpiece thickness and edge 50 tolerances. Tracing from top, bottom and sides. Pressure is applied at a right angle to the workpiece contour. RPM up to max. 12,000.

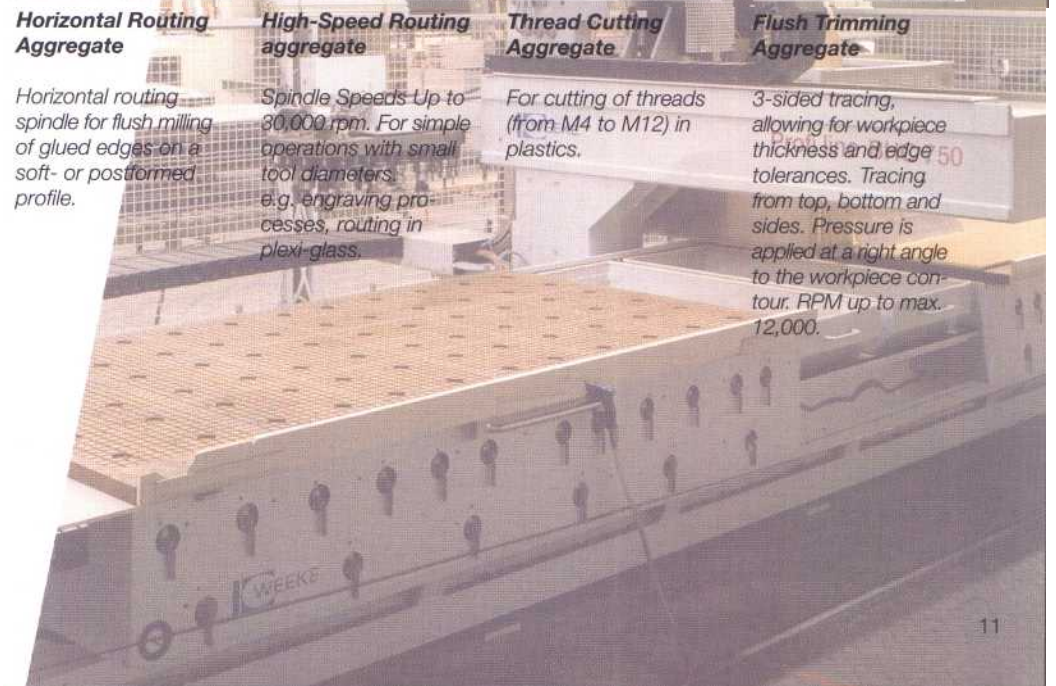
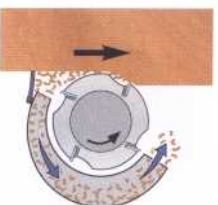

# Our Robust Tool Change System

Ride along tool change system:

Advantage:

- NC-controlled loading of the magazine
- easily accessible
- extremely safe operation
- crash prevention sensors
- fast and user-friendly
- X and Y ride along

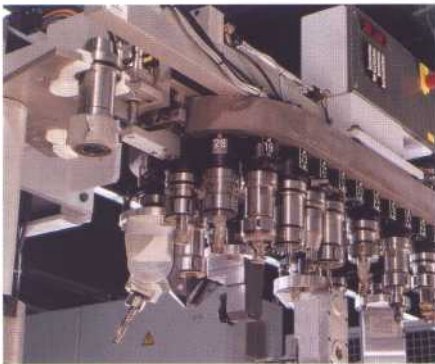

30-position tool changer



8- or 18-position magazine with X-axis ride along

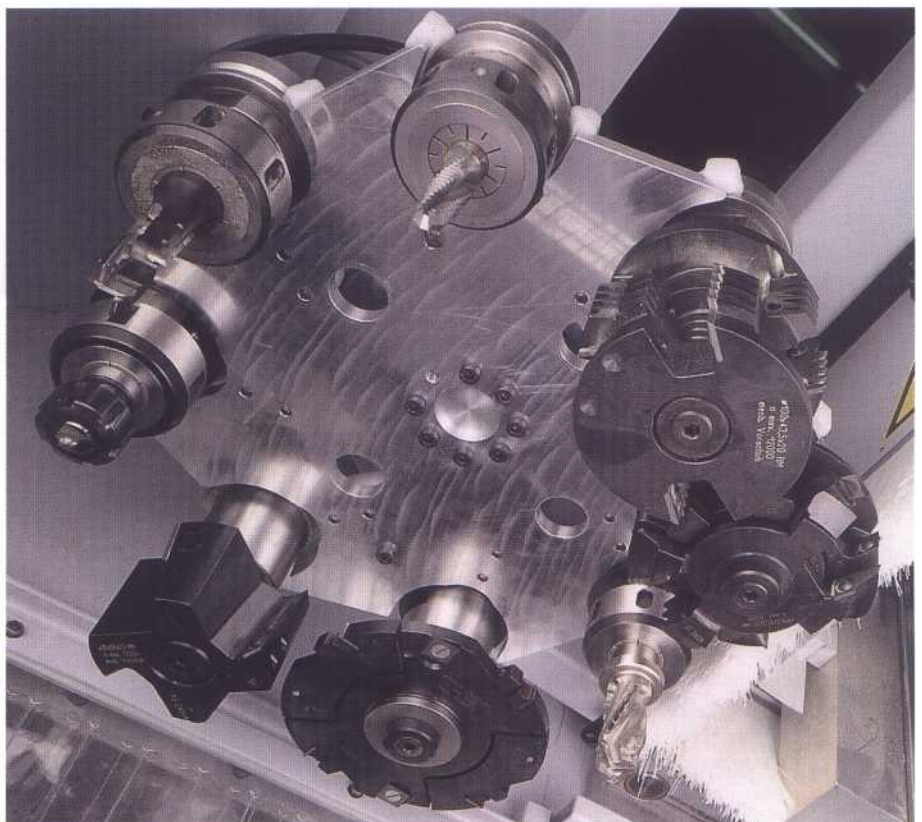
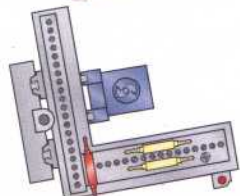
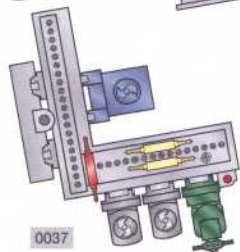
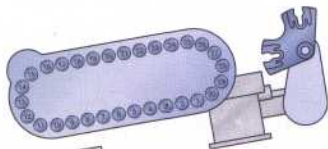

8-position magazine with X- and Y-axis ride along

# Highlights in Hard- and Software



The **WoodWOP programming software** and the **Homatic 2000 CNC control system** was developed in close co-operation with your requirements in mind.

Short cycle times are a must. Profitability is increased by a fast and easy programming system. Easy to work with and a high degree of reliability

features, together with your know-how will lead to a maximum of productivity.

The integrated interface between man and machine was realized by WEEKE with a PC-based System and the Microsoft Windows® world many years ago. Easy handling of the machine in day-to-day business is the result of this solution - you are proceeding with confidence.

**With WoodWOP you are programming your success.**

**WOP = Workshop-Oriented-Programming**

With WoodWOP you do not program the G and M codes of the machine and its movements but simply input the panel geometry and its processes.

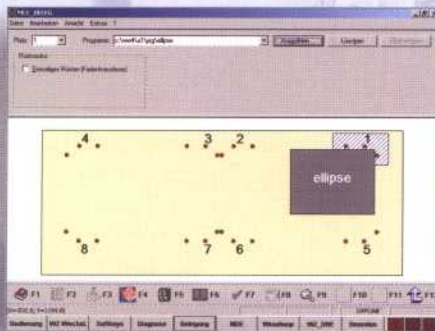

The integration of the Optimat BHC750/850 and the **profi** line BHC700/800 machines into your existing computer network and your barcode system are just a few of many options we have to offer. The control is already prepared for networking for simple transfer of part programs and information from your office.

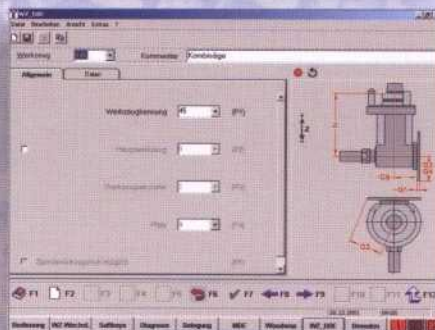
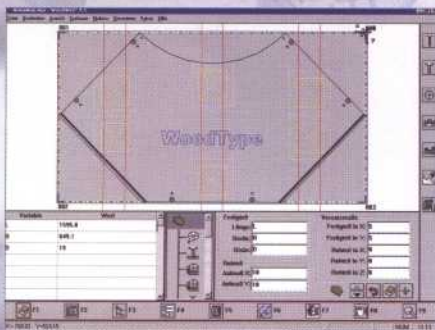

Numerous successful projects with major third party suppliers of cabinet design programs allows us the capability to handle any type of requirement in the CAD/CAM environment.

are hallmarks of the WoodWOP programming system.

Parametric programming and the possibility of structured components enhance the system further. These

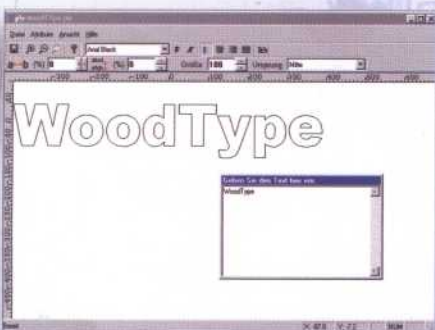

Photos may show optional items

# An overview of our technology

**Optimat BHC 750**  
with K-Table

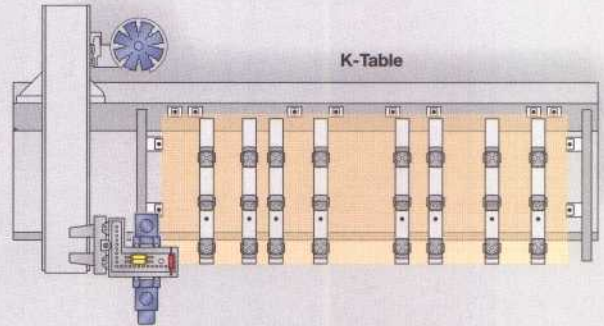

**Optimat BHC 850**  
with K-Table

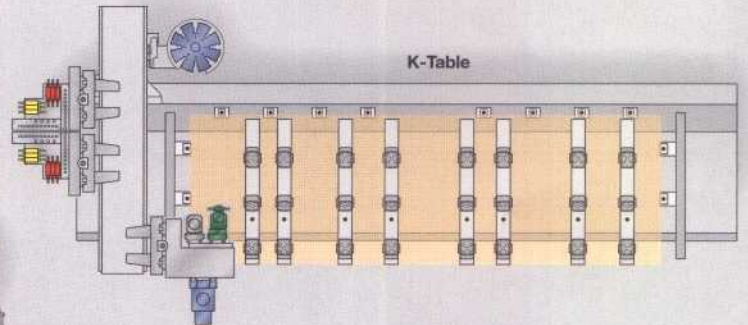
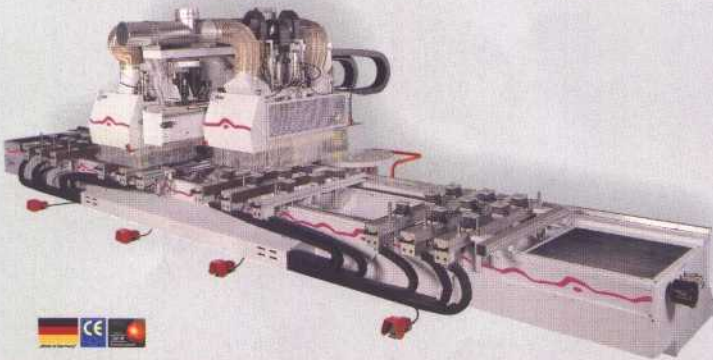

**profi line BHC 700**  
with K-Table

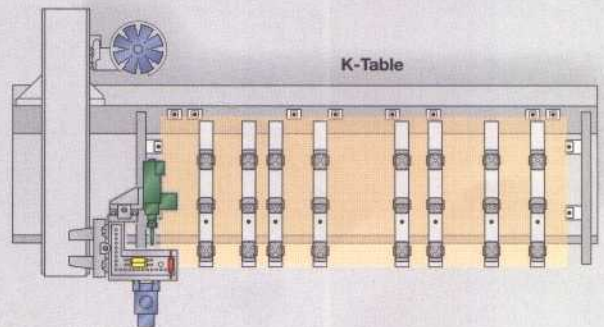
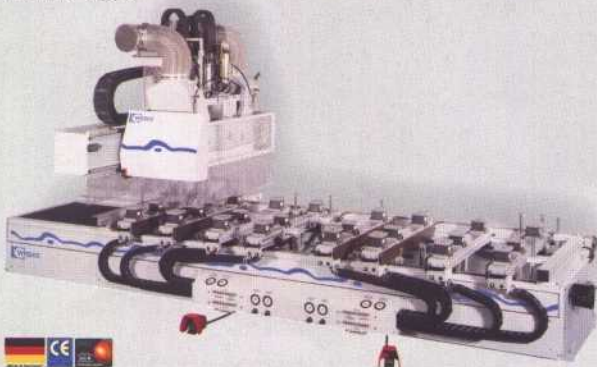

**profi line 800**  
with K-Table

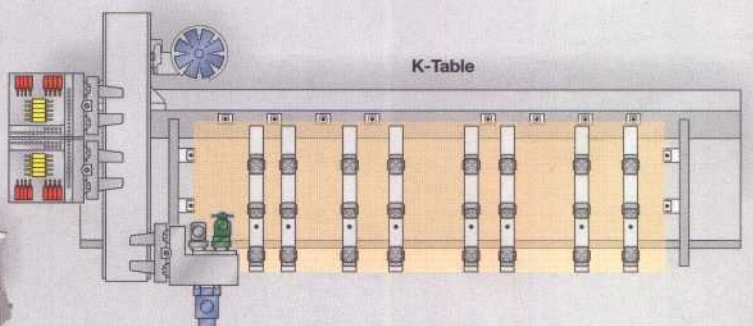
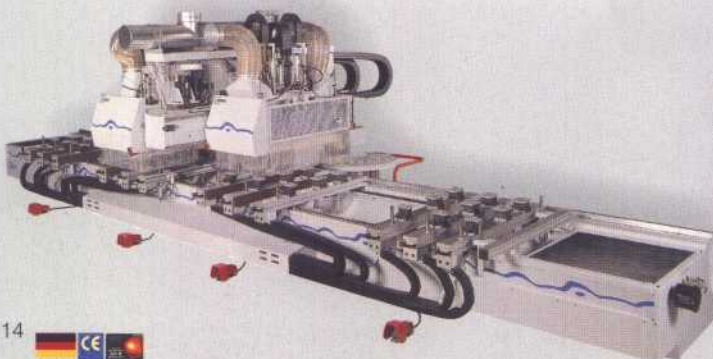

### Optimat BHC750

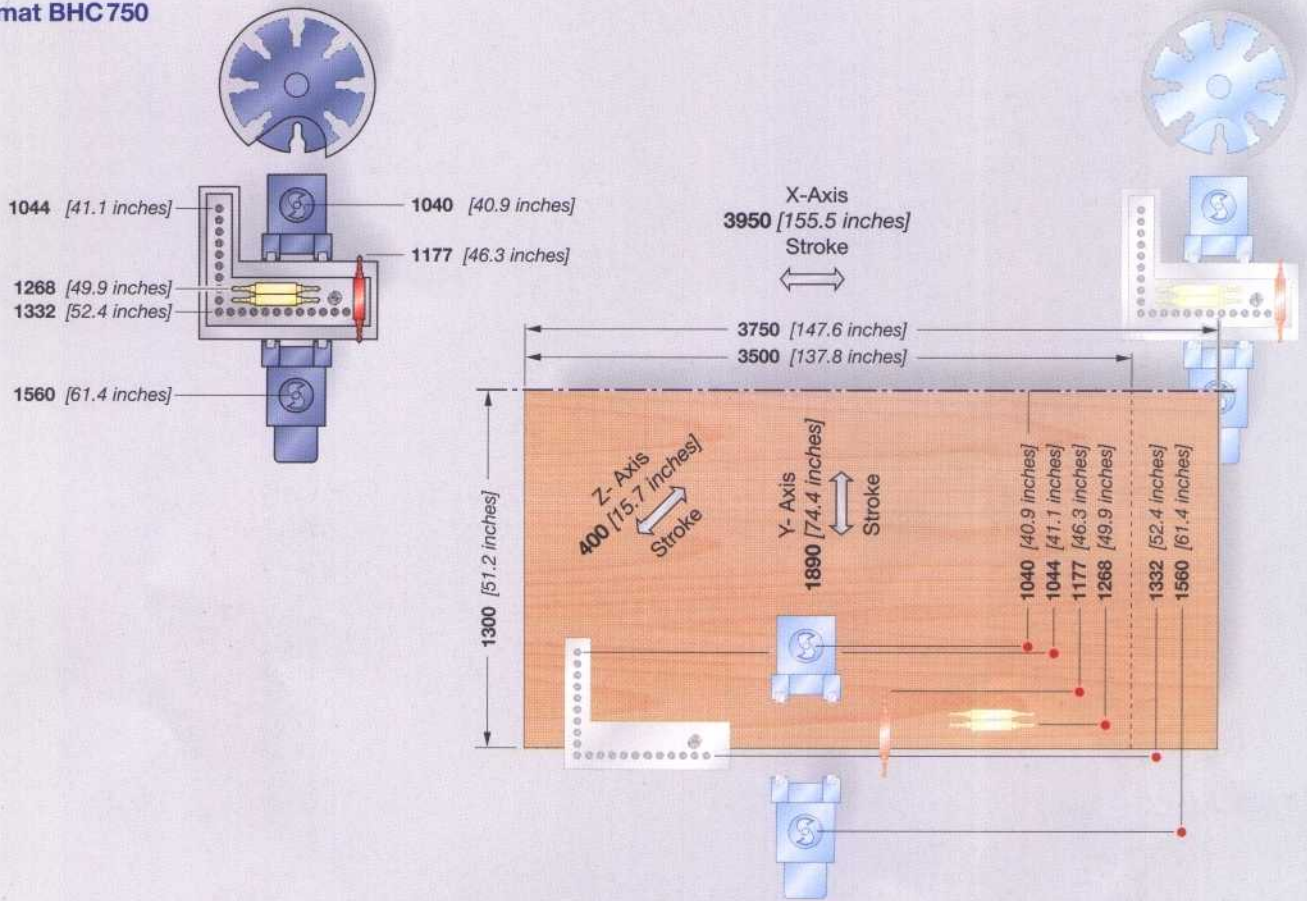

### Optimat BHC850

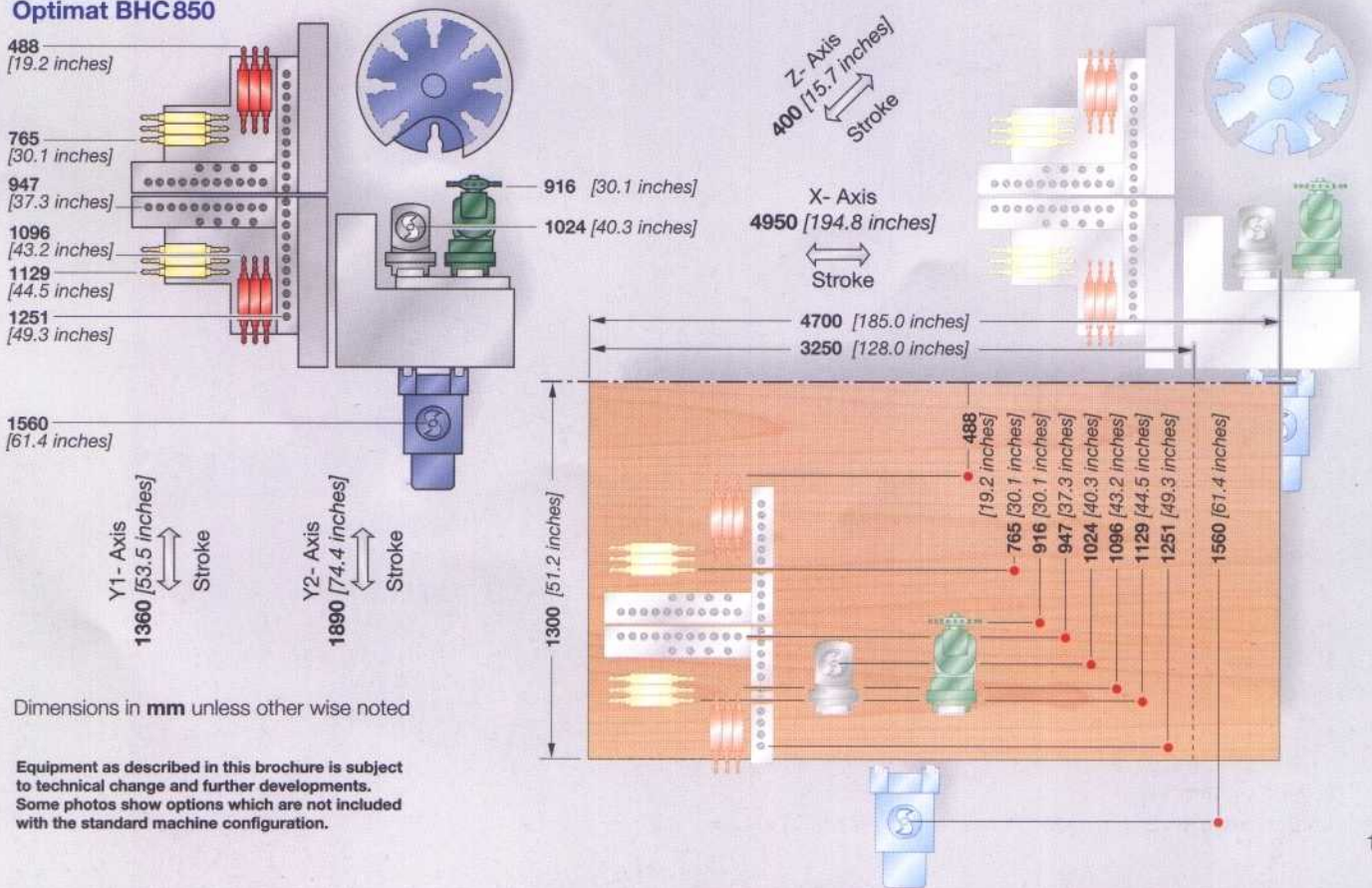

Dimensions in mm unless otherwise noted

Equipment as described in this brochure is subject to technical change and further developments. Some photos show options which are not included with the standard machine configuration.

## TECHNICAL DATA

### BHC 750

### BHC 850

Stroke of the Z-axis	mm	400/360	400/360
Maximum workpiece thickness	mm	100	100
Driving system of the axes		digital	digital
Positioning accuracy of the axis	mm	0.03	0.03
Rapid traverse rate X-Y-Z axes	m/min	80/80/20	80/80/20
Compressed air connection	dia	R 1/2	R 1/2
Compressed air required	bar	7	7
Vacuum pump capacity	m <sup>3</sup> /h	from 100 on	from 100 on
Dust extraction port diameter	mm	Ø 250 (1-2 x)	Ø 250 (1-2 x) Ø 160 (1-2 x)
Dust extraction air speed required	m/min	min. 28	min. 28
Dust extraction pressure drop	Pa	min. 2000	min. 2000
Dust extraction volume required	m <sup>3</sup> /h	min. 4950	varies according to
Electrical power – total connected load	kW	14-22	16-24
Total machine weight [for 3250 mm length]	kg	approx. 4500	approx. 5600

### Optimat BHC 750

Working-length	L	B
<b>3500</b> [127.7 inches]	approx. <b>6900</b> [approx. 271.6 inches]	approx. <b>4260</b> [approx. 167.7 inches]
<b>4500</b> [177.1 inches]	approx. <b>7900</b> [approx. 311.0 inches]	approx. <b>4260</b> [approx. 167.7 inches]
<b>5500</b> [216.5 inches]	approx. <b>7900</b> [approx. 311.0 inches]	approx. <b>4260</b> [approx. 167.7 inches]

Option: Electrical control cabinet on **left** side

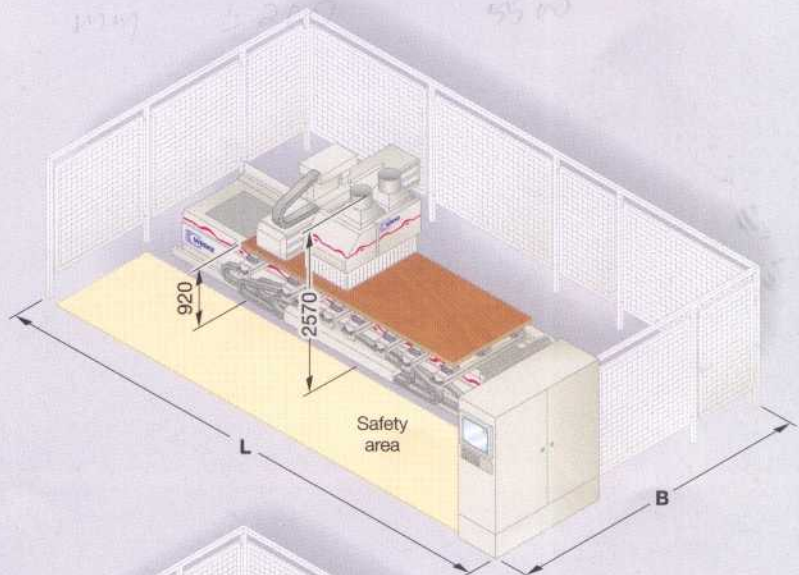

### Optimat BHC 850

Working-length	L	B
<b>3250</b> [127.9 inches]	approx. <b>8500</b> [approx. 334.6 inches]	approx. <b>5500</b> [approx. 216.5 inches]
<b>4250</b> [167.3 inches]	approx. <b>9500</b> [approx. 374.0 inches]	approx. <b>5500</b> [approx. 216.5 inches]
<b>5250</b> [206.7 inches]	approx. <b>10500</b> [approx. 413.3 inches]	approx. <b>5500</b> [approx. 216.5 inches]

Option: Electrical control cabinet on **left** side

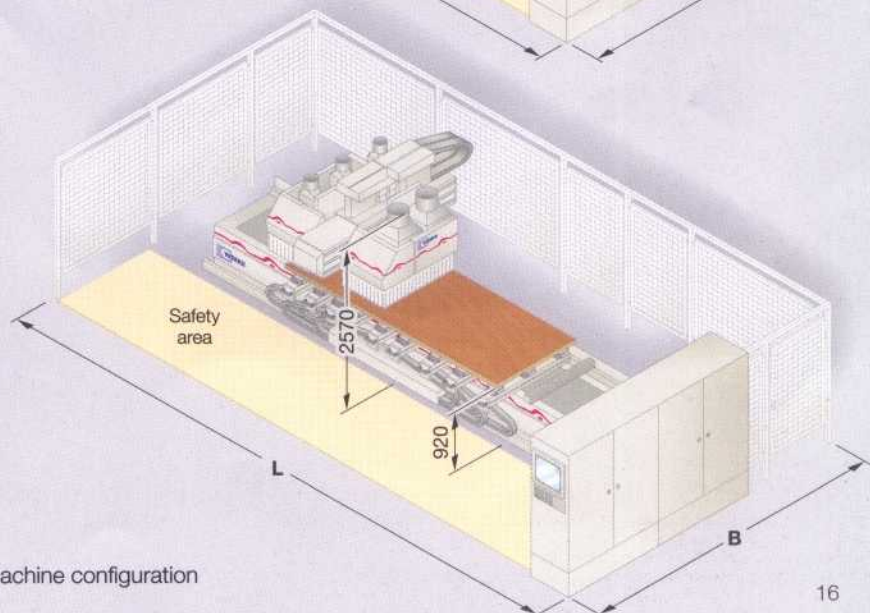

Dimensions in **mm**

Installation dimensions refer to the standard machine configuration



### Optimat BHC 750/850

#### Configuration Options

- ① 8-position tool change magazine ride along X-Axis
- ② 30-position tool change magazine
- ③ Vertical drilling spindles Y-Axis (individually selectable)
- ④ Main Router Spindle
- ⑤ Horizontal drilling spindles Y- Axis
- ⑥ Horizontal drilling spindles X- Axis
- ⑦ Vertical drilling spindles X-Axis (individually selectable)
- ⑧ Reinforced drilling spindle(s)
- ⑨ Crosshair laser (Option)
- ⑩ Grooving saw unit
- ⑪ Additional routing spindles
- ⑫ 18-position tool change magazine
- ⑬ 8-position tool change magazine ride along X- and Y-axes
- ⑭ Horizontal routing unit

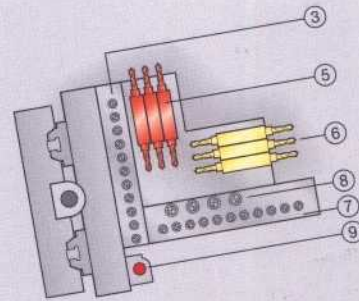

0031

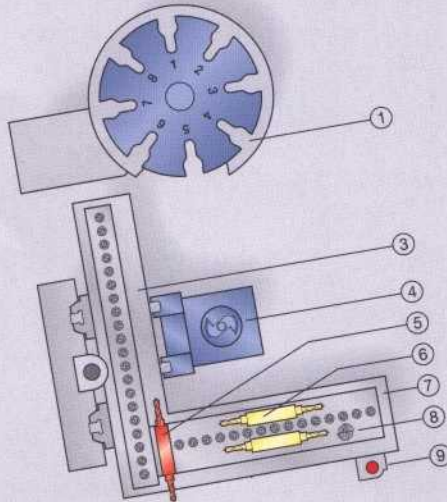

0035

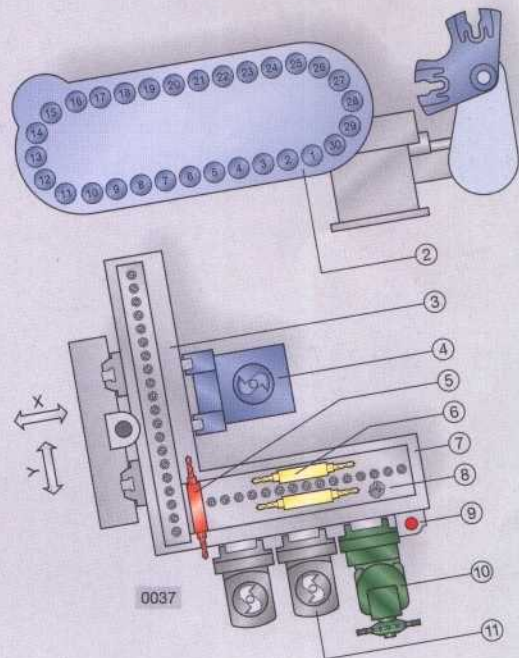

0037

Photos may show optional items

### profi line BHC 700/800

#### Configuration Options

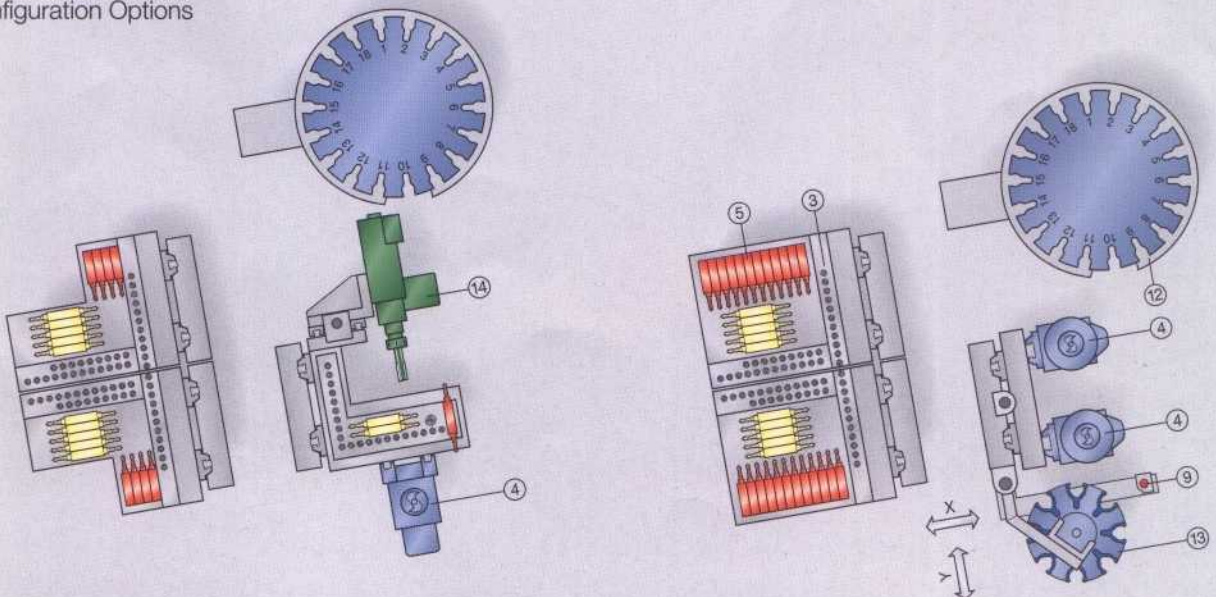

# Die Technik im Überblick

## Optimat BHC 750

mit K-Tisch

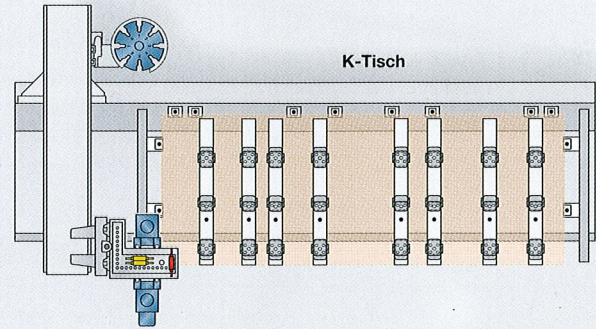
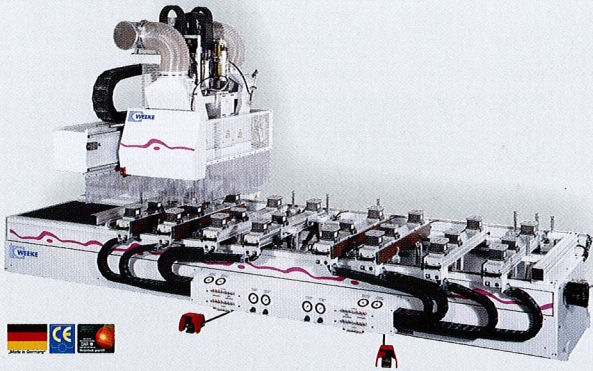

## Optimat BHC 850

mit K-Tisch

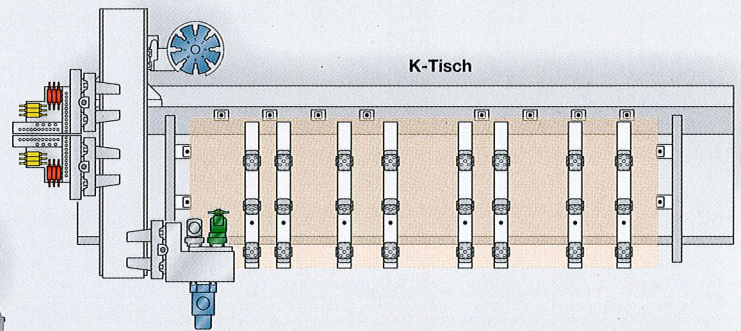
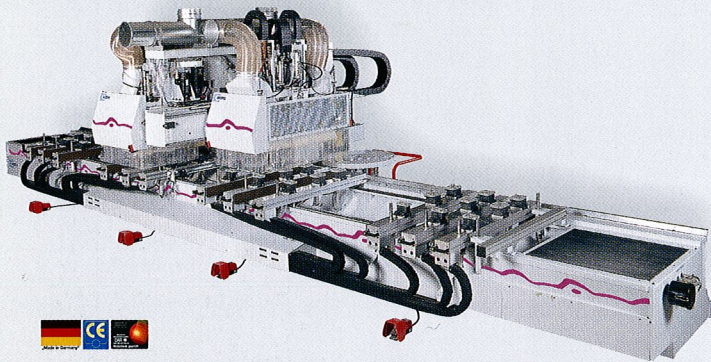

## profi line BHC 700

mit K-Tisch

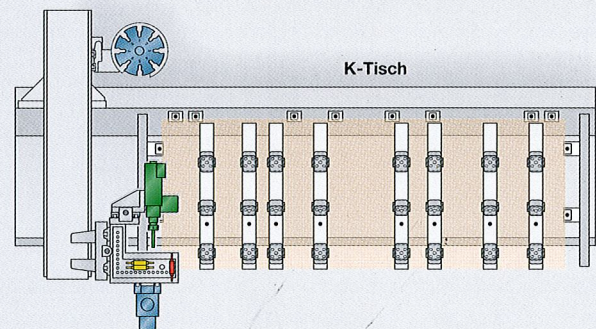
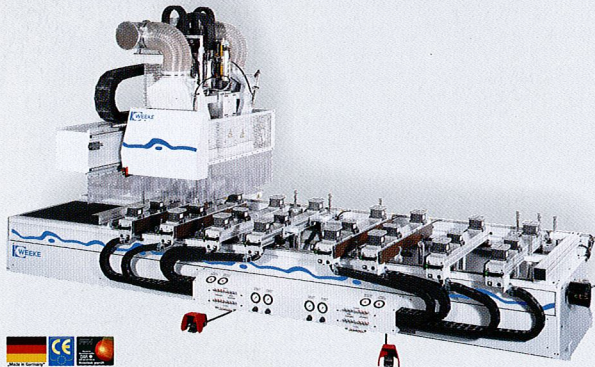

## profi line 800

mit K-Tisch

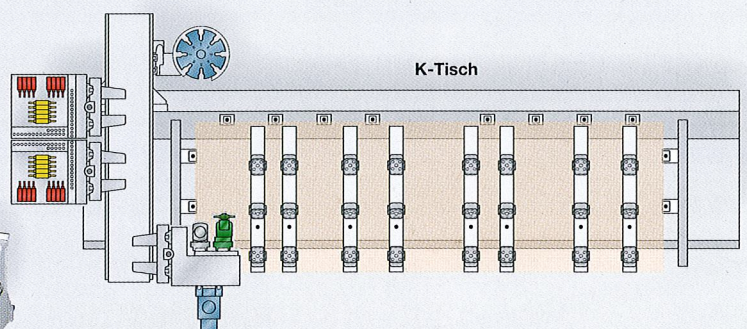
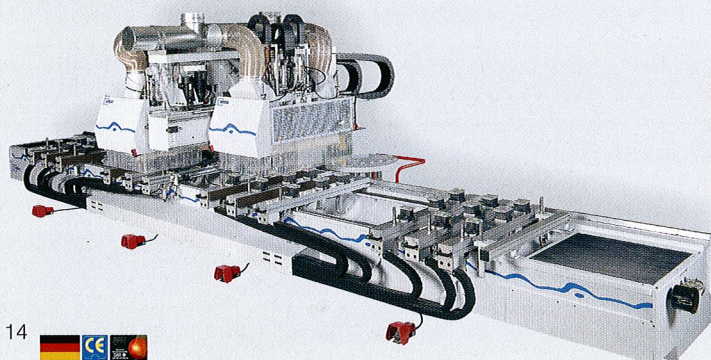

## Optimat BHC750

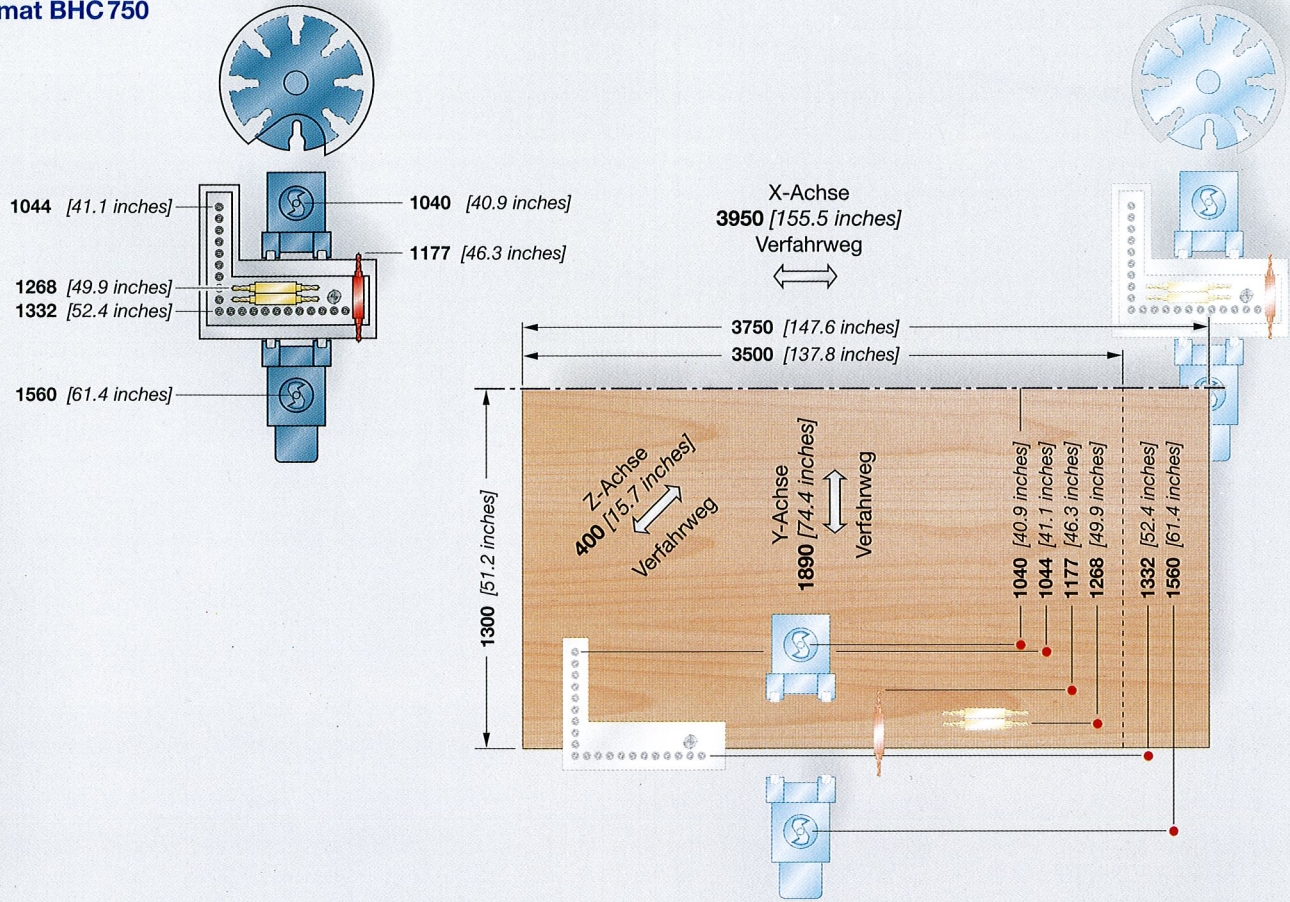

## Optimat BHC850

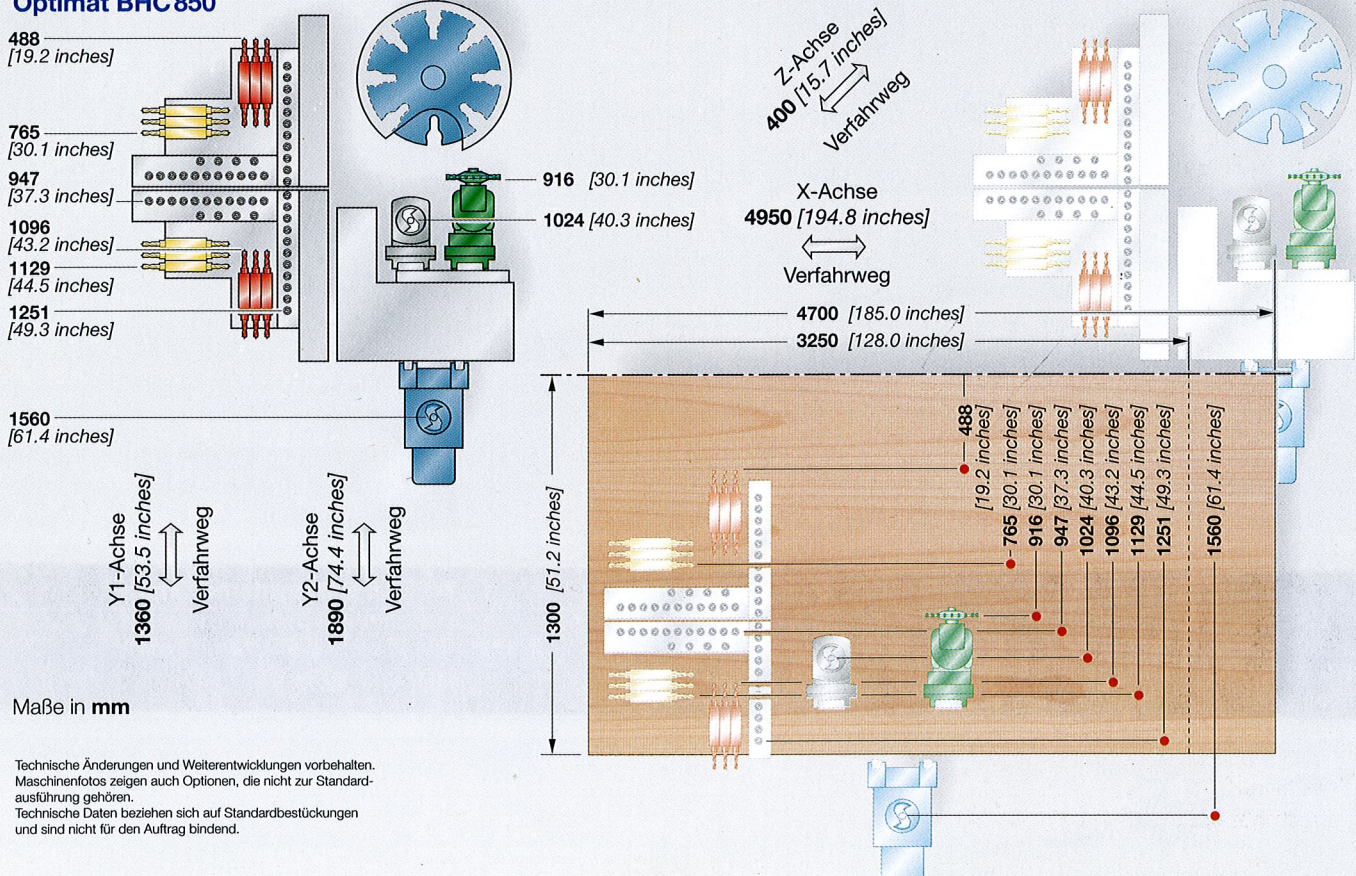

Maße in mm

Technische Änderungen und Weiterentwicklungen vorbehalten.  
 Maschinenfotos zeigen auch Optionen, die nicht zur Standardausführung gehören.  
 Technische Daten beziehen sich auf Standardbestückungen und sind nicht für den Auftrag bindend.

### Optimat BHC 750/850

Bestückungsmöglichkeiten

- ① 8-fach Werkzeugwechsellmagazin mitfahrend X-Richtung
- ② 30-fach Werkzeugwechsellmagazin
- ③ vertikale Bohrspindeln Y-Richtung (einzeln abrufbar)
- ④ Hauptspindel
- ⑤ horizontale Bohrspindeln Y-Richtung
- ⑥ horizontale Bohrspindeln X-Richtung
- ⑦ vertikale Bohrspindeln X-Richtung (einzeln abrufbar)
- ⑧ verstärkte Bohrspindel(n)
- ⑨ Fadenkreuzlaser (Option)
- ⑩ Nutsägeaggregat
- ⑪ zusätzliche Fräsmotoren
- ⑫ 18-fach Werkzeugwechsellmagazin (fix)
- ⑬ 8-fach Werkzeugwechsellmagazin mitfahrend X- und Y-Richtung
- ⑭ horizontales Fräsaggregat

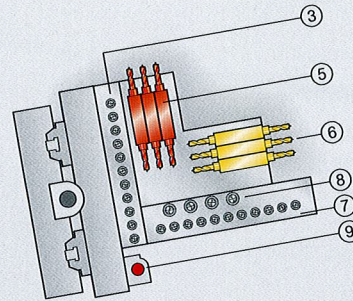

0031

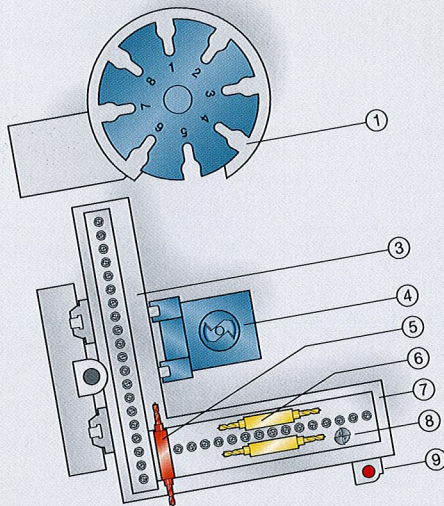

0035

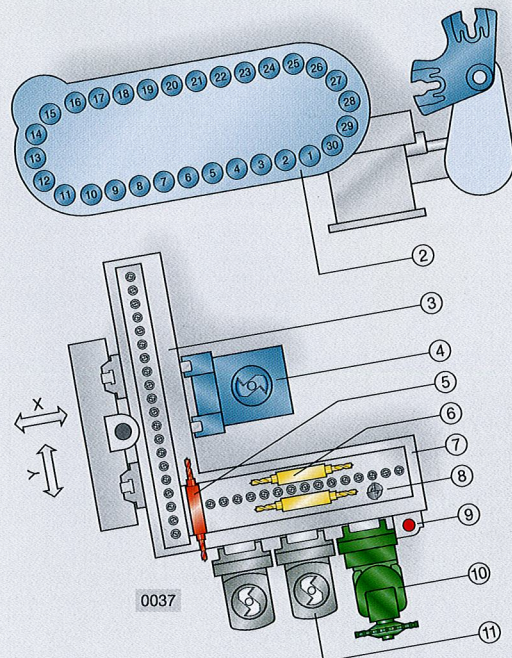

0037

Abbildungen können auch Optionen zeigen

### profi line BHC 700/800

Bestückungsmöglichkeiten

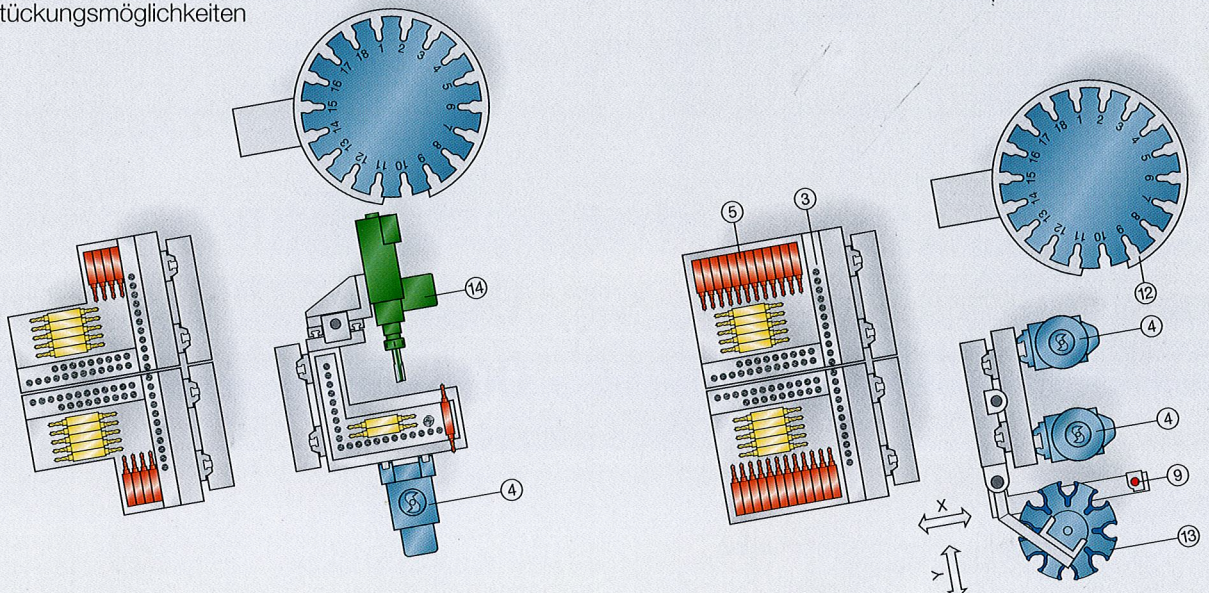

## TECHNISCHE DATEN

### BHC 750

### BHC 850

Verfahrweg der Z-Achse	mm	400/360	400/360
Werkstückdicke max.	mm	100	100
Antriebssystem der Achsen		digital	digital
Positioniergenauigkeit der Achsen	mm	0.03	0.03
Verfahrgeschwindigkeiten X-Y-Z	m/min	80/80/20	80/80/20
Druckluftanschluss	Zoll	R 1/2	R 1/2
Druckluft	bar	7	7
Leistung der Vakuumpumpe	m³/h	ab 100	ab 100
Zentraler Absaugstutzen	mm	Ø 250 (1-2 x)	Ø 250 (1-2 x) Ø 160 (1-2 x)
Absaugluftgeschwindigkeit	m/min	min. 28	min. 28
Druckverlust	Pa	min. 2000	min. 2000
Gesamtabsaugleistung	m³/h	min. 4950	ausstattungsabhängig
Elektrische Anschlussleistung	kW	14-22	16-24
Maschinengesamtgewicht [bei 3250 mm]	kg	ca. 4500	ca. 5600

### Optimat BHC750

Arbeitslänge	L	B
<b>3500</b> [127.7 inches]	ca. <b>6900</b> [ca. 271.6 inches]	ca. <b>4260</b> [ca. 167.7 inches]
<b>4500</b> [177.1 inches]	ca. <b>7900</b> [ca. 311.0 inches]	ca. <b>4260</b> [ca. 167.7 inches]
<b>5500</b> [216.5 inches]	ca. <b>7900</b> [ca. 311.0 inches]	ca. <b>4260</b> [ca. 167.7 inches]

Optional: Schaltschrank **linke** Seite

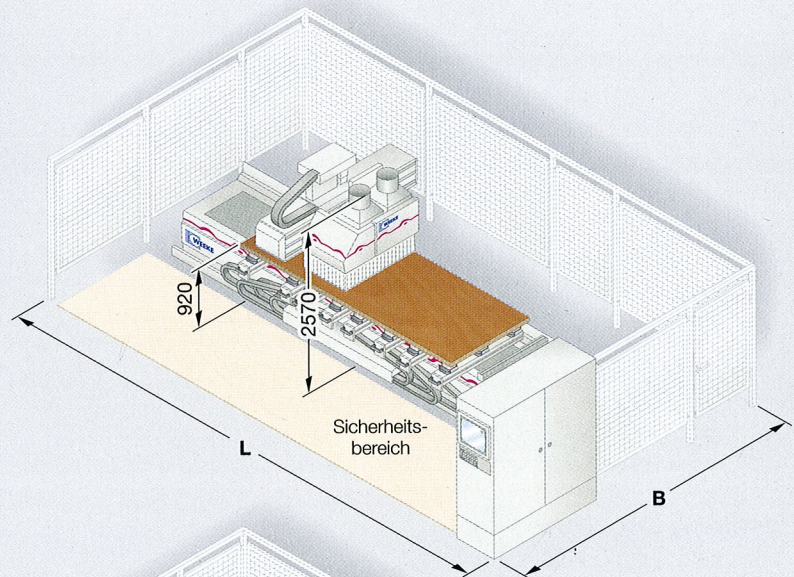

### Optimat BHC850

Arbeitslänge	L	B
<b>3250</b> [127.9 inches]	ca. <b>8500</b> [ca. 334.6 inches]	ca. <b>5500</b> [ca. 216.5 inches]
<b>4250</b> [167.3 inches]	ca. <b>9500</b> [ca. 374.0 inches]	ca. <b>5500</b> [ca. 216.5 inches]
<b>5250</b> [206.7 inches]	ca. <b>10500</b> [ca. 413.3 inches]	ca. <b>5500</b> [ca. 216.5 inches]

Optional: Schaltschrank **linke** Seite

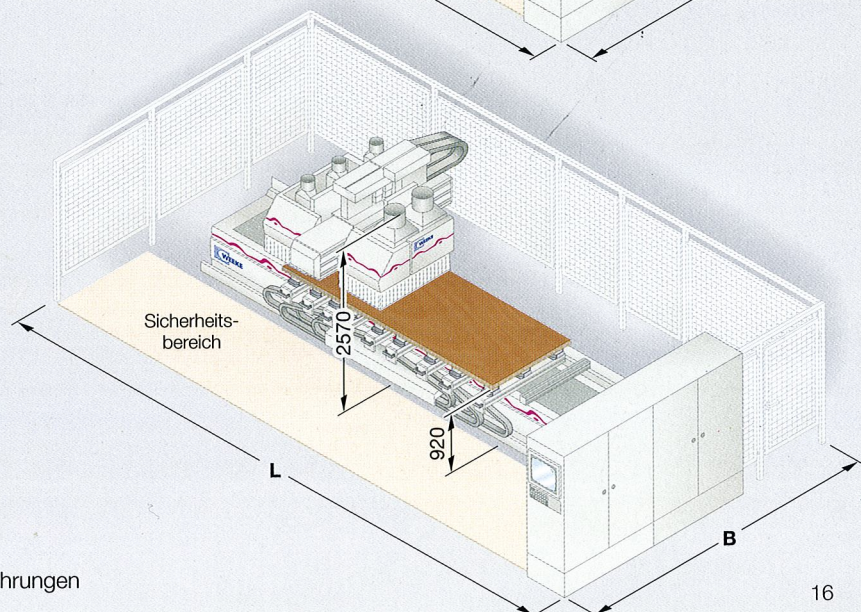

Maße in **mm**

Aufstellmaße beziehen sich auf Standardausführungen

---

A member of the international HOMAG-Group



**WEEKE Bohrsysteme GmbH**  
Benzstraße 10-16  
33442 HERZEBROCK-Clarholz  
GERMANY  
Phone +49-5245-445-0  
Fax +49-52 45-4 45-139  
info@weeke.de www.weeke.de