

# COMBISCAN SENSE SERIE

Intelligent optimization scanner  
for all applications



# Cutting edge scanner technology by the optimizing specialists from WEINIG

The WEINIG CombiScan Sense series sets new benchmarks in the development of scanner technology. This innovative and completely redeveloped product portfolio provides an increase in performance and a clear advancement in scanning, without losing any of

the traditional advantages such as reliability, accuracy and flexibility. This scanner series is based on a single platform, adapted for all applications in solid wood manufacturing. By adding software modules and optional sensors to the base model, you can extend the scanner to

the ideal optimizing machine – perfect for your demands. Together with other machines from WEINIG you have the best equipment for an efficient and economic production. CombiScan Sense can be combined with various WEINIG machines for cross-cutting, ripping and sorting.

# One for all applications: That makes SENSE

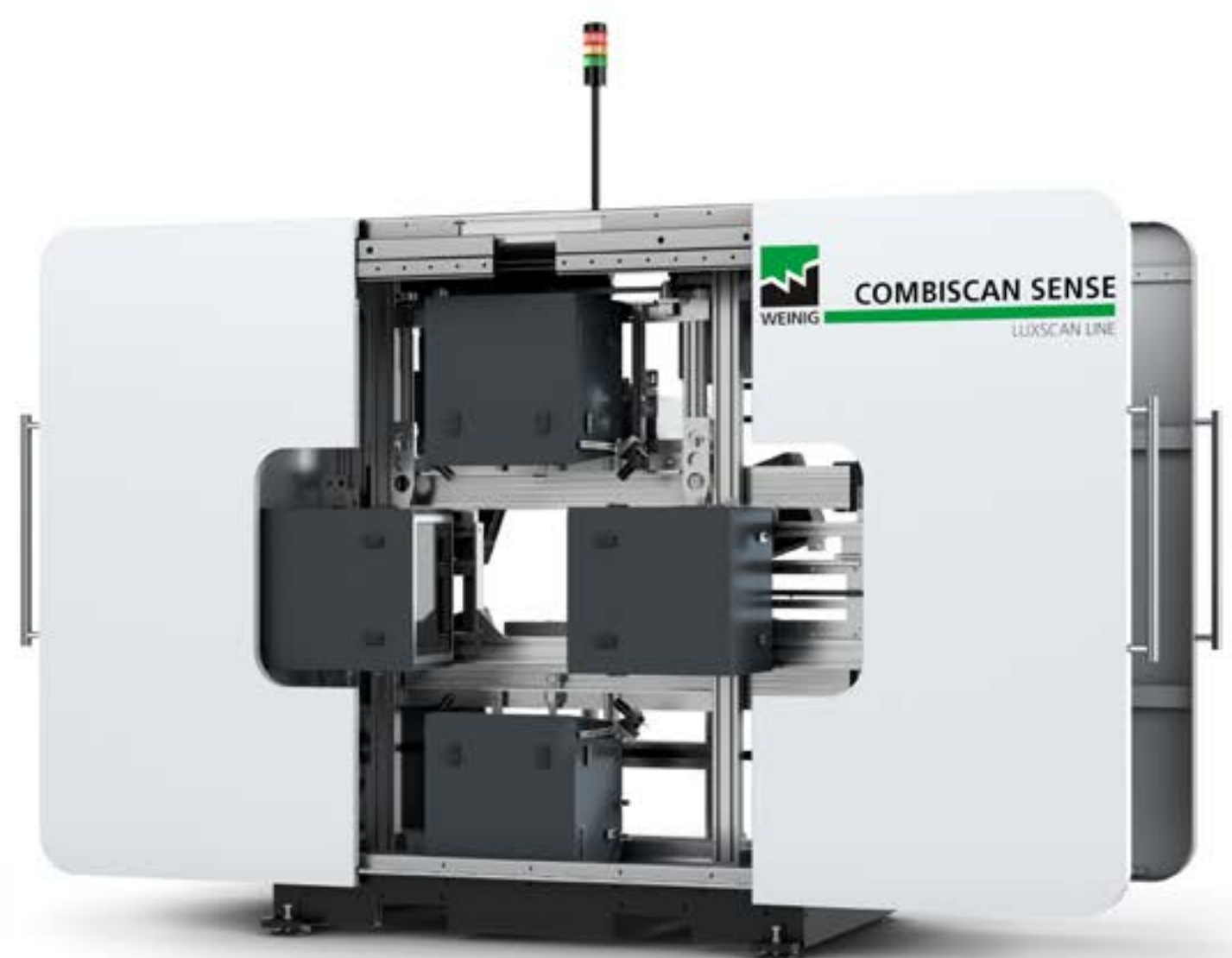

## The sensors: Key to success



### Laser cameras – the proven sensor technology

All sensors are protected within a sealed climate control system. As a standard our systems are fitted with laser cameras. With the highest speed available on the market the best detection and results are guaranteed. With the continuous development in these industrial sensors, the performance is continually improving. Using this technology, it is possible to identify defects such as knots, pith, cracks etc. The laser system also allows detection of 3D surface defects such as holes, wane and edge defects.

### Colour cameras provide further possibilities

Our new generation of colour cameras comes as standard and improves the detection of the scanner. A higher resolution in both length and width measurement provides a higher detection of coloration and of different defects, including cracks and insect damage, than before.

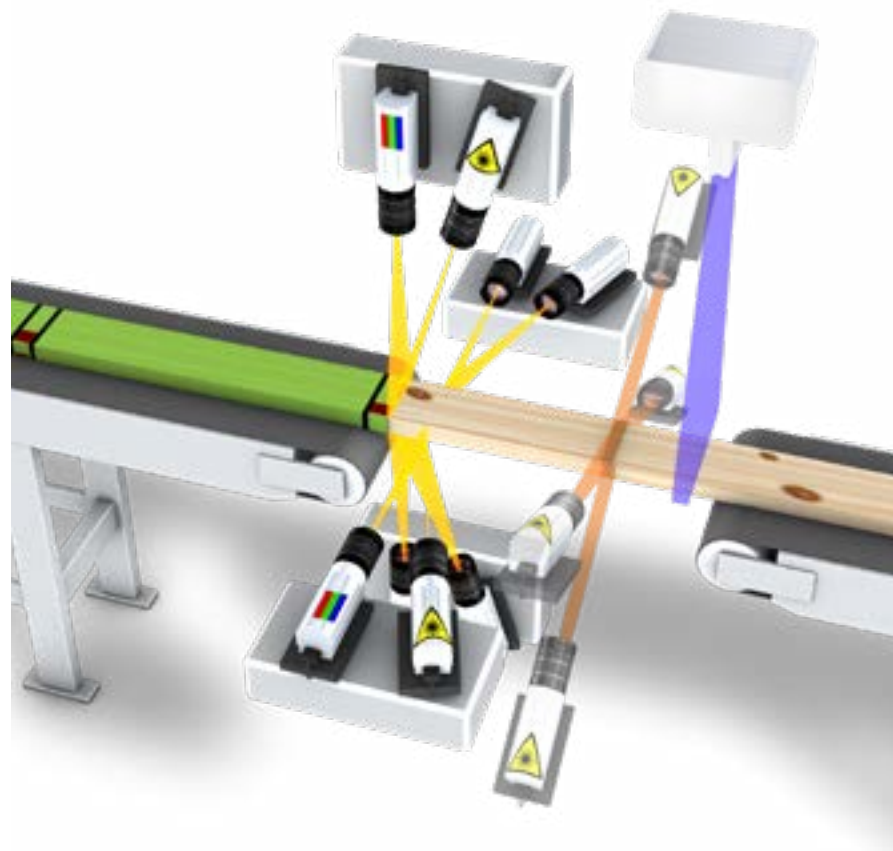

## Fibre analysis: Maximum cut accuracy

An important part of maximizing yield and profit is locating the correct cut position, especially for fingerjoint products. Dual scatter technology, consisting of one line and one dot laser provides this accuracy. While the line laser is mainly used for the detection of knots, cracks and resin pockets the additional dot lasers, will improve defect detection, especially on rough surfaces. Cut positions can be improved based on angle and shape of the dots. This helps to prevent damage in fingerjoint applications and to identify weak areas in strength grading products. Both hard and soft-wood can be processed.



## Automatic positioning



Automatic camera positioning ensures the cameras are in the ideal position to achieve the best resolution and image quality. It also prevents mistakes in set-up, meaning production errors are reduced to the minimum.

This is also a requirement for the best results when scanning random width. Adjustment is made in real-time giving the best result for each board. A double servo configuration ensures accurate positioning even for high-speed applications processing high piece-counts.

Random width capability can be fitted to any CombiScan Sense at any time. This option makes the scanner a viable long term investment.

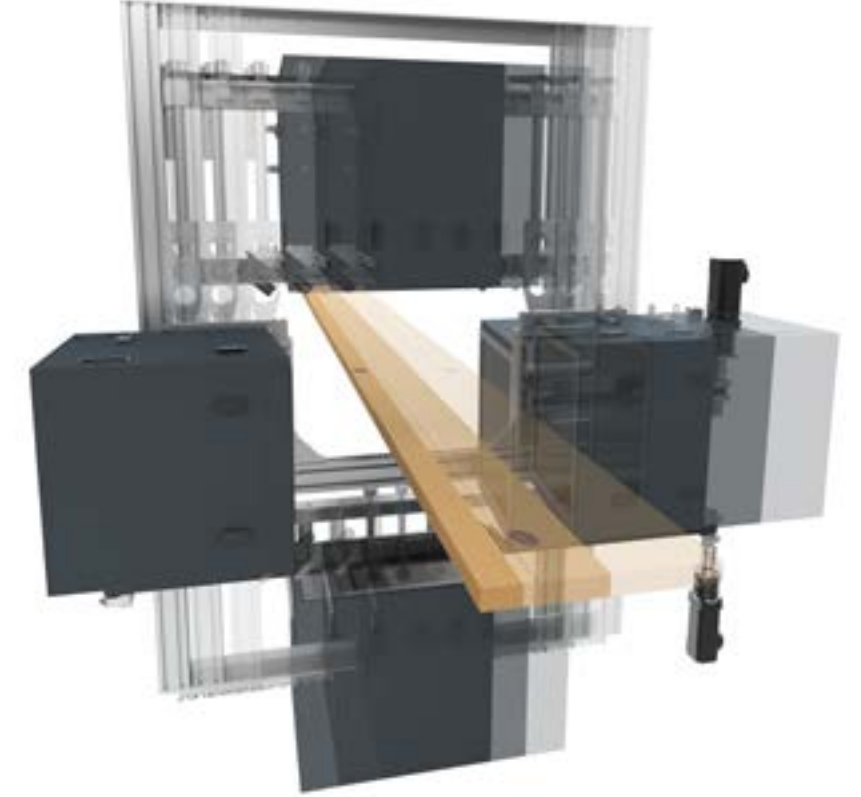

## Xray sensor: Enhanced defect detection

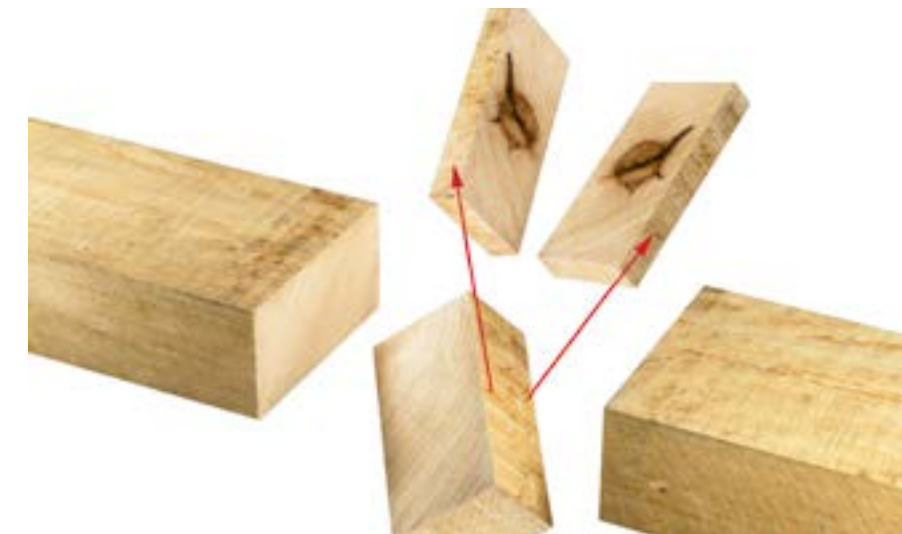

The advantage of the low power xray is that defects can be identified and localized due to the difference in density. Knots, for example, can be easily identified by their higher density, independent of the surface quality. Dirt, dust, grease, water marks and other colour characteristics no longer provide limitations in the detection of knots. Xray detection is not only recommended for rough or soiled timber but can also be useful for wood containing substantial colour variations. Furthermore, the xray can also be used for density measurement and strength grading applications.



## Angle crack module ACM: Improve your crack detection



The detection of flat, non-vertical cracks has always been limited due to the positioning of the lasers. Operating with 4 specially positioned lasers the Angle Crack Module is able to provide additional information. By creating an additional contrast, the scanner is able to highlight flat and difficult cracks on top and bottom faces. Furthermore, this way the general crack detection has been improved as well as minimising the risk of over-detection.



## Roughness+ for detection of unplanned areas



In some applications unplanned areas are considered as a defect. In this case our Roughness+ sensors for top and bottom deliver good results. Rough areas can be detected and removed or valued differently in the optimization.

Due to the advanced frame structure of the CombiScan Sense, both Roughness+ and Xray sensors can be combined and will turn the CombiScan Sense into an all-in-one scanning solution.

## Exact product definition ensures high yield and performance

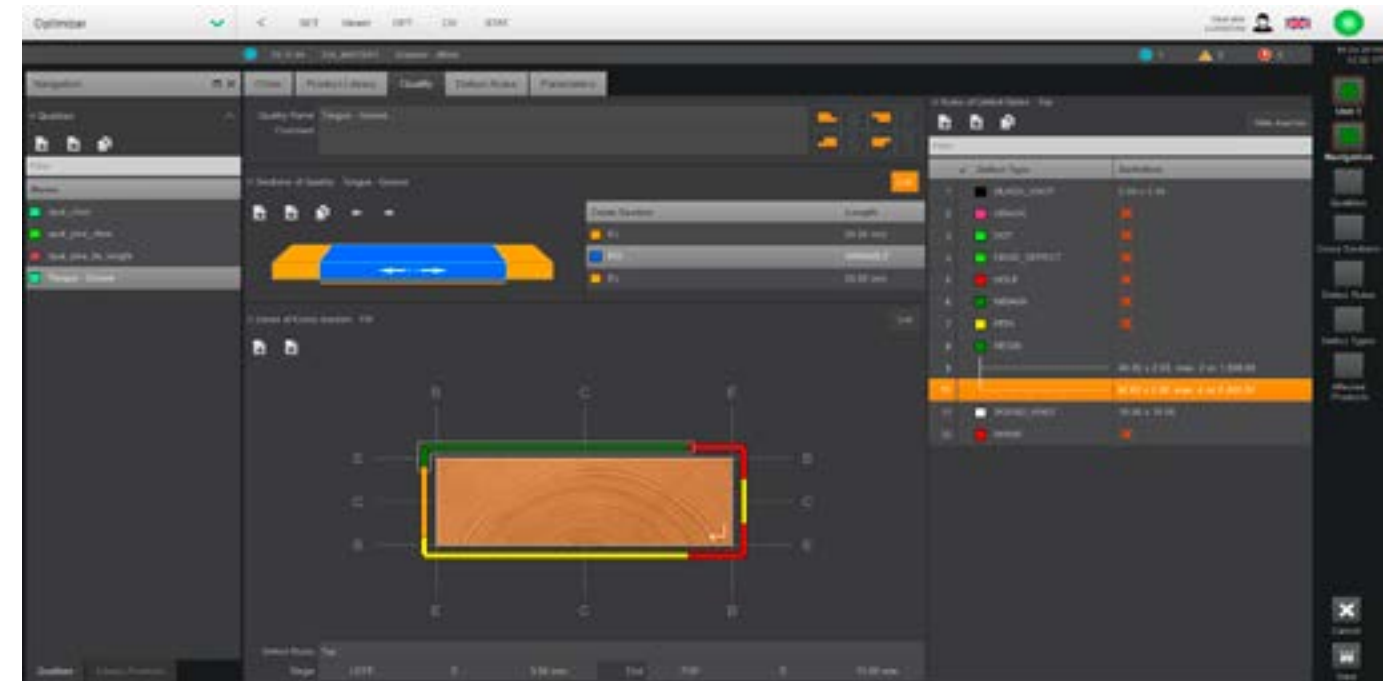

Simple optimizing is the key to efficient production management. The powerful optimizer, OptiCore, allows you to program multiple

qualities and zones, tailored to your final product requirements. Multiple products and qualities are stored in a library and can be quickly and

easily combined using the "drag and drop" feature. The logical interface of the scanner improves the set-up which is simple for any operator to use.



# Optimizing - the one, two, three

**Step 1.** Our scanners use multiple sensor technology such as laser cameras, colour cameras and xray\*. Suitable for many applications your WEINIG expert will advise on the appropriate scanner based on the wood species, surface quality and required performance. Our goal is to achieve the best possible information quality for each customers' application.



**Step 2.** In the next step, image processing, the highly developed OptiCore software takes over. It can see and identify different defects as well as colour variations on the board. Quality data from the multiple sensors allows for optimal data processing and defect identification.



**Step 3.** The optimization from the powerful OptiCore software provides the best solution for cross-cutting, ripping\* or sorting. It takes into account various customer requirements and quality demands. Based on the exact characteristics identified during image processing, the board is optimized according to customer

requirements. There are unlimited possibilities in the definition of products and qualities. By dividing the products into diverse zones, complicated qualities can also be easily dealt with. Therefore all kind of end products can be produced.

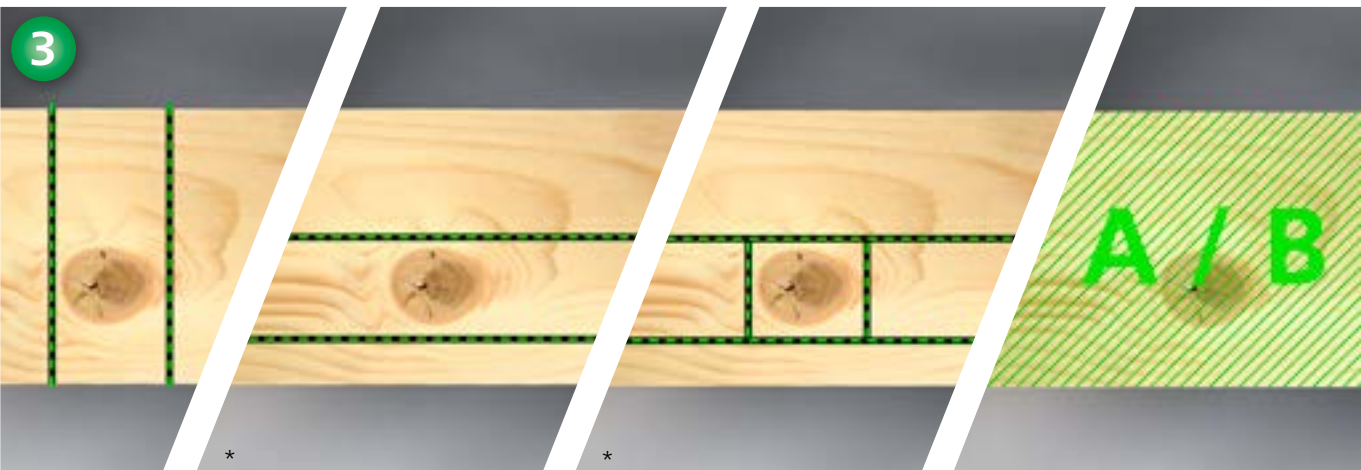

\* not available in all scanner models



## The C module for cross-cutting

The CombiScan Sense C is specially set-up for cross-cutting. It can be adapted to most demands through a wide range of options offering exceptional flexibility. Based on the tested cutting edge technology from WEINIG it can measurably improve your production.



## The R module for ripping

With its extended 2D optimizing software the CombiScan Sense R is a valuable addition to your rip saw. With an optimization according to product, and not only to width, the ripping decision is improved considerably. The possibilities of this system are so high that no laser line width optimizer can compete.



## The S module for sorting

With the S version of the CombiScan Sense S offers multiple options in board and profile sorting. Similar to the C and R version external information such as shape and moisture content can also be incorporated. Together with the repetitive accuracy of the optimization the accuracy of the sorting is increased. Quality differences caused by human error are a thing of the past.





## Unlimited possibilities: process optimization with the highest return

CombiScan Sense can be effectively applied in many different applications, not only the classical single chop and rip versions but also a combination of both. From simple, entry level saw lines to complex production facilities incorporating multiple, additional features such as grading or colour

matching, the CombiScan Sense is the perfect partner, not only for today's production demands, but also for anything else that tomorrow might bring. CombiScan Sense provides the perfect platform for increased productivity with maximum control.

## OptiLink: Advanced optimizing by combining processes



Running complex processes has always been a difficult task. Combining different applications and production lines complicates the flow of information. OptiLink has been designed to optimize production management by centralizing the information flow.

With only one access point to your production, producing just-in-time is no more a complex task. OptiLink minimizes operating errors on one hand and reduces work in progress (WIP) on the other, which is a central benefit. Connectivity to ERP systems ensures easy access and

data transfer. Based on advanced statistic functions, production of specific parts can be made to order. Originally designed to combine rip and crosscut processes OptiLink is now able to combine all kind of processes and machines in cutting applications.

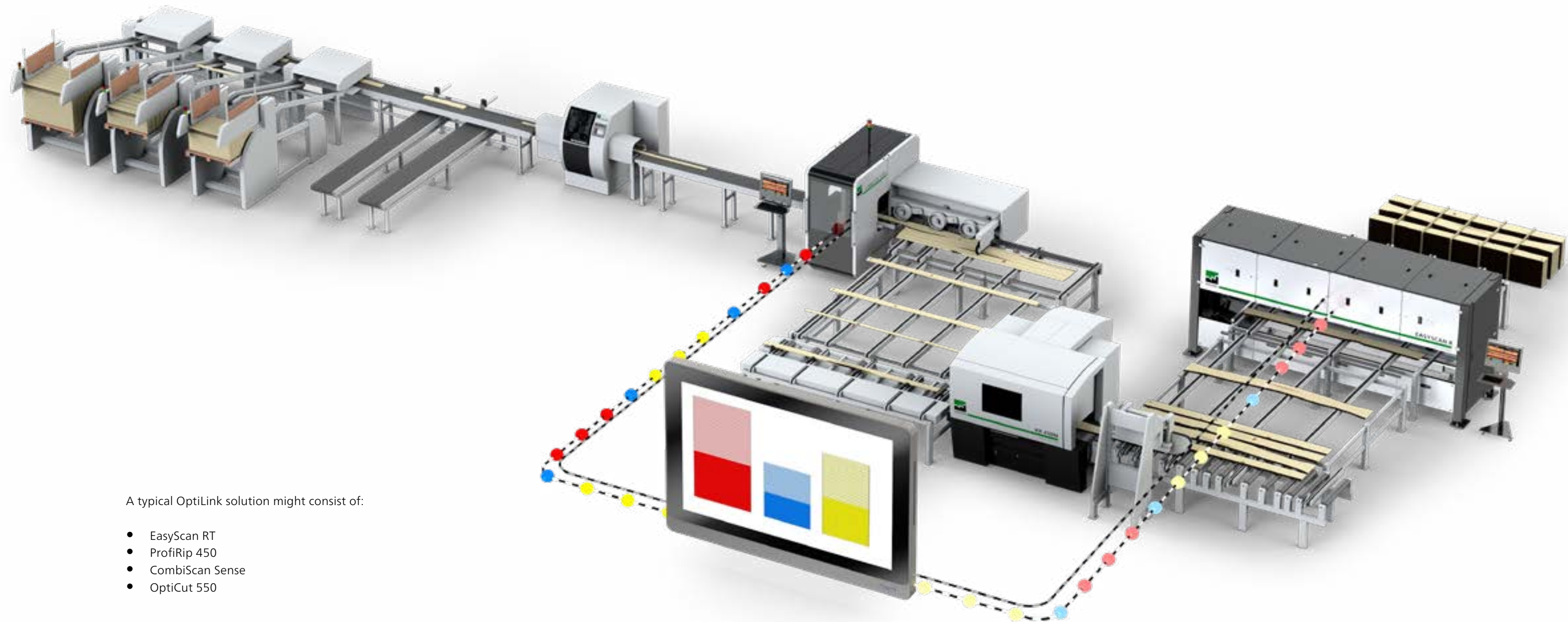

A typical OptiLink solution might consist of:

- EasyScan RT
- ProfiRip 450
- CombiScan Sense
- OptiCut 550



One scanner and one crosscut saw

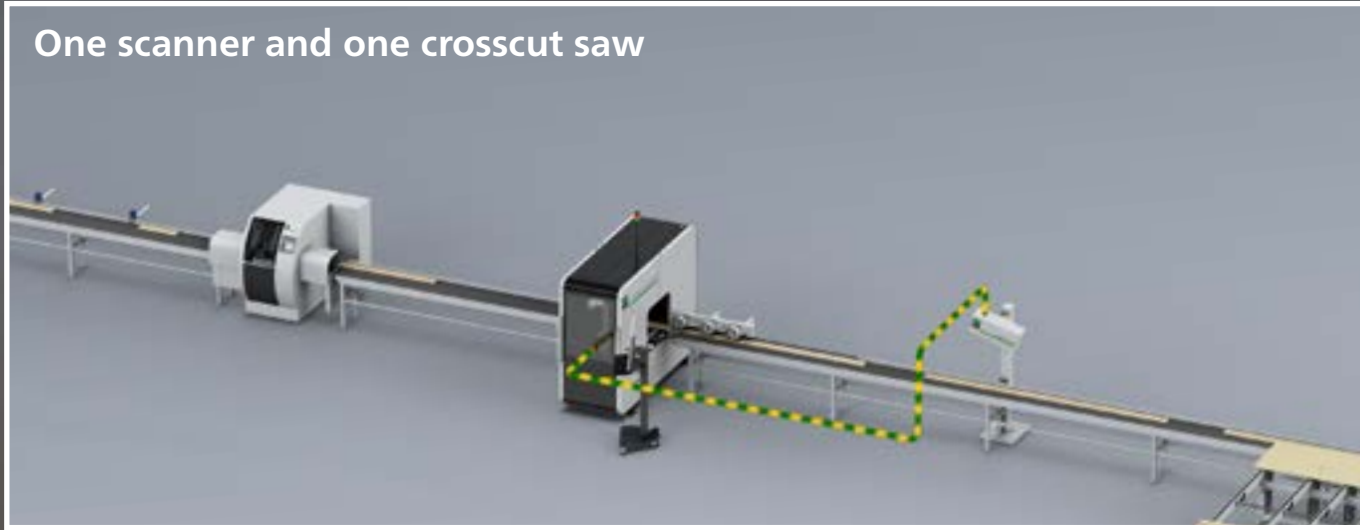

One scanner with one or two rip saws



One scanner and two crosscut saws

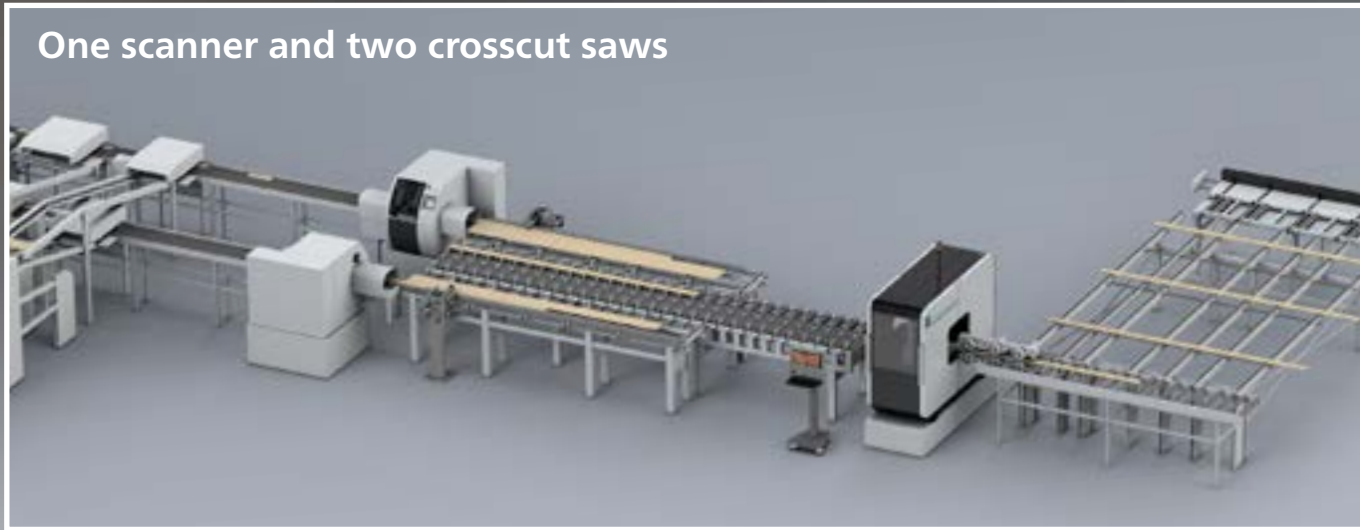

One scanner and one PowerJoint

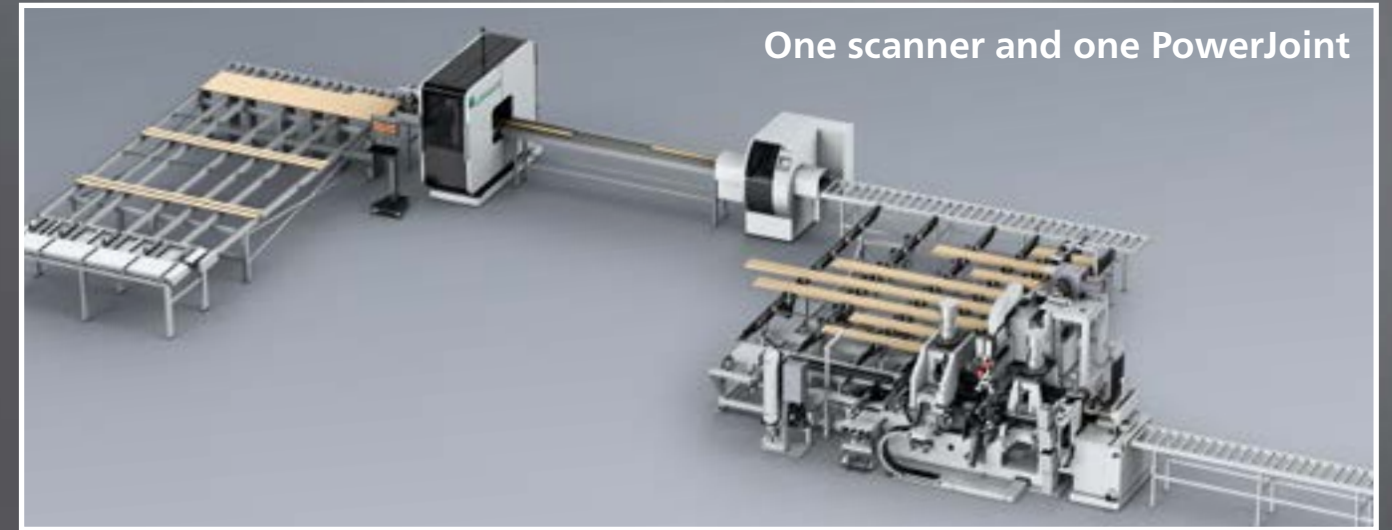

One scanner and more than 2 crosscut saws

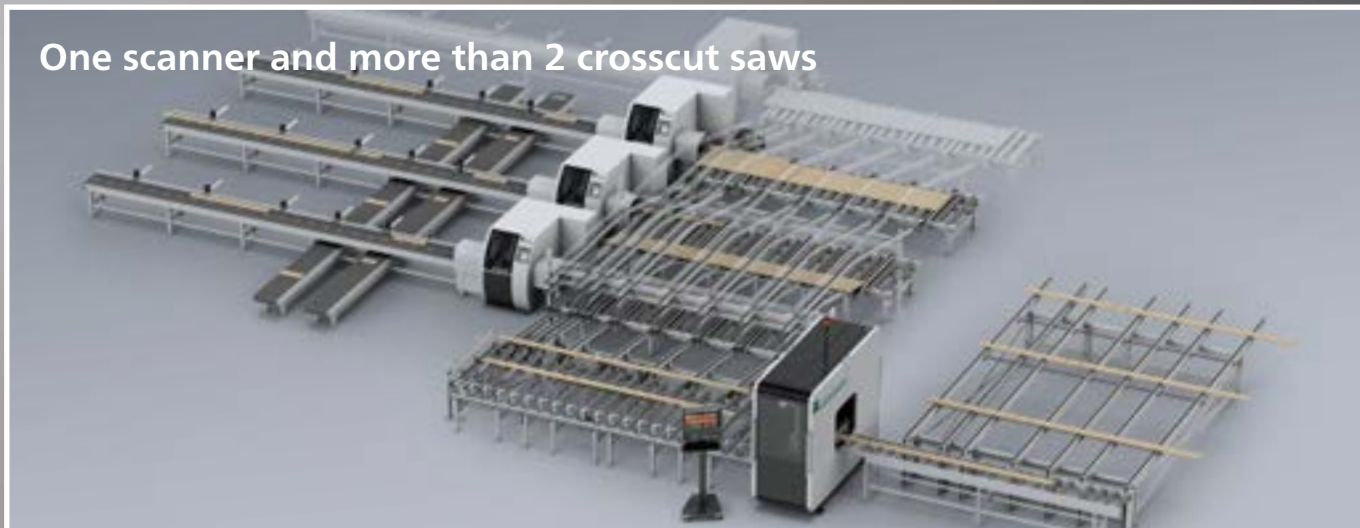

One scanner in a sorting line

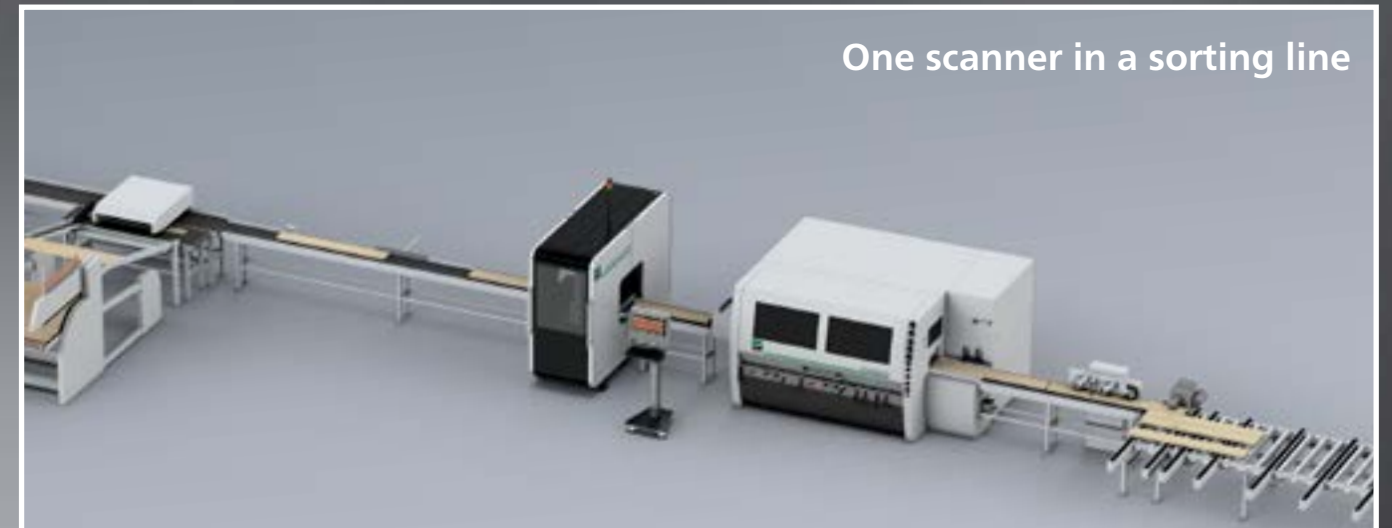



## ShapeScan: Detection of twist and bow



The ShapeScan is the ideal option when a certain degree of bending, bow or twist is to be detected. The measurement of cup is optional. The ShapeScan T uses multiple sensors to measure transversally on any cross conveyor. The ShapeScan L measures in a longitudinal direction. The shape data can be included in the optimization so that, for example, a maximum bow per product is allowed. As a stand alone product it can be used to remove pieces out of tolerance.

## Front End Scanner: The easy way to cross check quality

The Front End Scanner is a system mounted behind a crosscut saw, to scan both ends of the cut pieces. With its internal contrasting defects such as pith can be detected. That information can be used to regrade pieces going to a fingerjointer or for products which are later split, minimizing rework and maximising yield. It can be added to existing scanner lines as well as manual marking lines.



## Strength grading: A useful option for construction timber



Optimizing according to density or strength grading is becoming more important. Information about the density and strength can be measured using the xray and/or fibre analysis, or can be imported from external sensors such as the Escan. For grading applications different certification such as EN 14081 / JAS / MGP are available.

As above, external information about the moisture content of the timber can be incorporated into the optimization process.

## Marking station: Mark cuts and qualities

The perfect solution to connect a scanner to multiple existing optimizing crosscuts, without the need for complex mechanisation or where mechanical or data connection is not possible. Cuts, qualities and rotations can all be printed on each cut piece, providing the perfect identification for further processing. The marking station is also a useful addition in strength grading and sorting lines.

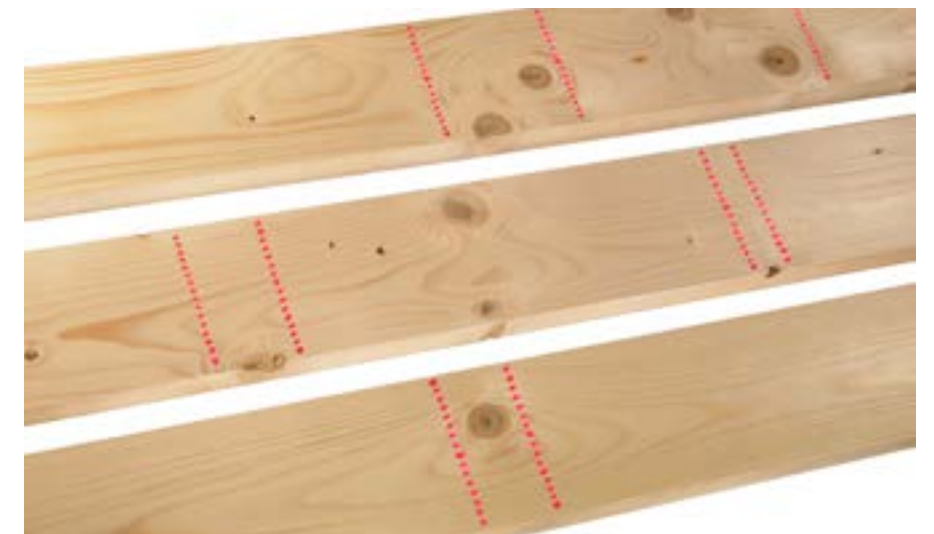



# Overview of the CombiScan Sense series: Standard specification and options

The table shows the standard technical specifications. For further, more detailed information according to your individual needs please contact an expert from WEINIG.

| Technical Data                   | CombiScan Sense C | CombiScan Sense R | CombiScan Sense S |
|----------------------------------|-------------------|-------------------|-------------------|
| Max. speed (m/min)               | 120 – 350 *       | 50 – 180 *        | 80 – 450 *        |
| Max. boards/min                  | up to 80 *        | up to 30 *        | up to 100 *       |
| Max. throughput linear m/min     | 220 *             | 120 *             | 300 *             |
| Min. / Max. input length (mm)    | 900 – 6500 *      | 900 – 6500 *      | 900 – 6500 *      |
| Min. / Max. input width (mm)     | 35 – 310 *        | 100 – 620 *       | 35 – 310 *        |
| Min. / Max. input thickness (mm) | 15 – 120 *        | 15 – 100 *        | 15 – 120 *        |
| Hardwood / Softwood              | ● / ●             | ● / ●             | ● / ●             |
| Working height (mm)              | 920 *             | 920 *             | 920 *             |

## Standards and options (internal)

|   |               |       |               |
|---|---------------|-------|---------------|
| Laser camera 2 S – 4 S                    | ●             | ●     | ●             |
| Colour camera (high definition) 2 S – 4 S | ●             | ●     | ●             |
| LED – lighting                            | ●             | ●     | ●             |
| Line laser                                | ●             | ●     | ●             |
| Fibre analysis                            | ○             | ○     | ○             |
| ACM                                       | ○ max. 230 mm | –     | ○ max. 230 mm |
| Xray detection                            | ○             | –     | ○             |
| OptiStrength (EN 14081 e.g.)              | ○             | –     | ○             |
| Random width detection                    | ○             | ●     | ○             |
| Profile module                            | ○             | –     | ○             |
| Cooling / Heating for sealed camera boxes | ● / ○         | ● / ○ | ● / ○         |
| Roughness+                                | ○ max. 230 mm | –     | ○ max. 230 mm |

## Options (external)

|                          |   |   |   |
|--------------------------|---|---|---|
| Scanner mechanization    | ○ | ○ | ○ |
| ShapeScan                | ○ | ○ | ○ |
| Front End Scanner        | ○ | – | ○ |
| Strength Grading (EScan) | ○ | – | ○ |
| Moisture measurement     | ○ | ○ | ○ |
| Marking station          | ○ | ○ | ○ |

● Standard ○ Option

\* Other speeds, dimensions or working heights upon application. All scanners will be matched to customer requirements. For this reason technical details may vary. Technical changes possible. Statements and illustrations in this brochure include optional extras which are not included in the standard specifications. Covers sometimes removed for photographic purposes.

## Other scanners available



### EasyScan: The economical optimizing solution

The EasyScan series opens up the possibility of fully automated optimizing for any company size. Low investment costs together with simple production control provide multiple economical possibilities. With the EasyScan scanning becomes affordable for everyone.

### EasyScan+: High performance, low budget

The EasyScan+ series has all the attributes of a hi-end scanner. It closes the gap between the entry level EasyScan and the hi-end CombiScan Sense. This innovative scanner has been developed from the successful CombiScan Series. It features high performance combined with reasonable pricing. With the EasyScan+ hi-end optimizing becomes affordable for everyone.



### EScan strength grading

The EScan marks a step into a new application for WEINIG. With EScan the product portfolio has been increased to optimized stress grading. A variety of different stress grading options is available now for the production of gluelam beams, DUO,TRIO and other strength based products. Benefit from the increases in performance and check out the multiple options and combinations with our EasyScan, Easy-Scan+ or CombiScan Series.



## Foetz, Luxembourg: Centre of Excellence for Engineering and Manufacturing



### WEINIG offers more

#### We are here for you.

Comprehensive advice, for example on optimum process integration of your new scanner, is standard service at WEINIG as well as a well-tested training plan with effective training sessions. Our branches in all four corners of the earth and an extensive service team guarantee rapid help where and when you need us.



Advice



Training

MORE  
EFFICIENCY  
OR MORE  
FLEXIBILITY?  
WHY NOT  
BOTH?

THINK WEINIG

My customers' needs are dynamic and I need to level up to meet them. From mass production today to mass-customization tomorrow, times of great change bring new challenges daily. I need a partner who not only sells us a machine, but guides our team into the future with comprehensive advice and scalable, flexible production solutions. **WEINIG offers more.**

Your link to the next level: [think.weinig.com](https://www.think.weinig.com)





# COMBISCAN SENSE SERIES

---

20210217\_COMBISCAN\_SENSE\_V3.0\_EN



**WEINIG GROUP**

[sales@weinig.com](mailto:sales@weinig.com)  
[www.weinig.com](http://www.weinig.com)