



Profimat 23E

New!

The little newcomer to the Weinig range of moulders with the power of elephants!

Made in Germany

Prepared for retro-fitting of the CAS-Logopac system (computer-aided machine set-up and tool organization system)



This is the Profimat for anyone who wants to plane and mould high-quality products more economically.

Weinig quality!
At a great price!



Profimat 23E. The Weinig Green Class.

The Profimat 23E. This machine is built with many of the same components used in the production of the powerful Weinig Unimat Class.

sensational!

This is why we can offer this machine at such an excellent price. This is why it is so efficient. The base: made of solid cast-iron guarantees extremely smooth running. The high-precision spindles, spindle slides, bed plates,

fences and pressure elements are designed and manufactured to demanding specifications to provide the outstanding quality of the products that you demand from a genuine Weinig. Pneumatic pressure for feed

rollers. Cardan drive system utilizing universal joints in the feed wheel shafts transferring driving power to the product through patented feed wheels. The same features as on the Weinig high-speed machines. All these

features ensure positive workpiece drive through the machine. (And longer service life!) Axial adjustment for all spindles. All adjustments are at one height, and the digital readouts! That's operating comfort! Finally, this Weinig machine has earned the CE quality mark, the guarantee for the highest safety level attainable for woodworking machinery.

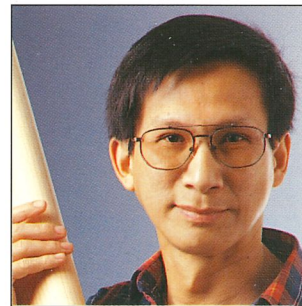

"What are the features?"
Planes more smoothly than you have before. Moulding: Furniture components, windows, doors, ornamental mouldings, frames, broom sticks, toys. And a lot more.



"Do I have enough space in my workshop for the Profimat 23E?"
Yes! Although this is a five-spindle machine it is only 3.3 m long and 1.5 m wide.

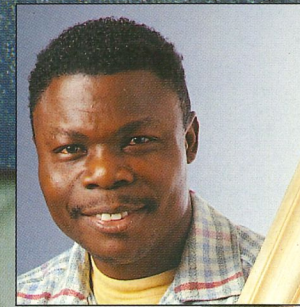

"Who trains us?"
The factory trained Weinig technician who installs the Profimat 23E in your workshop will train you and your staff. You'll be able to use your Profimat to the full from the very first day on.

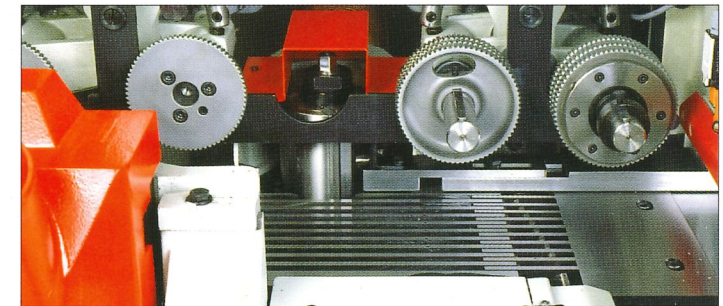

Groove guide system for precise surfacing and edge-jointing provides highest glue line quality.

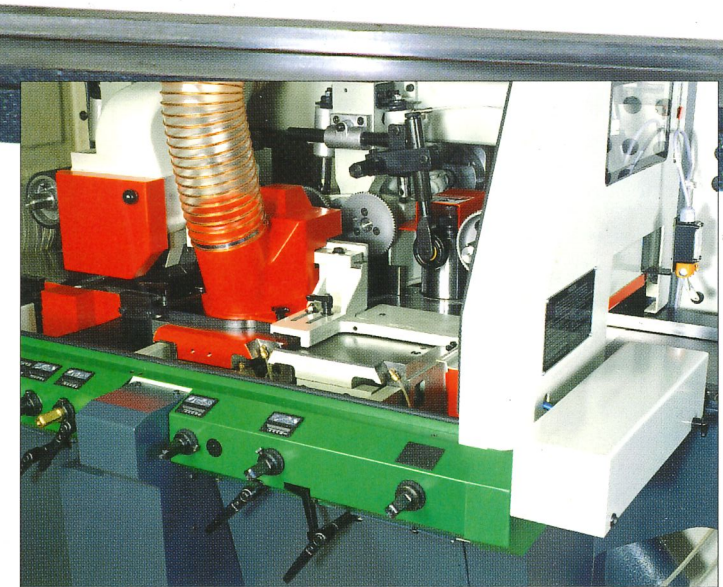

The mobile left spindle is multi-talented. Incoming random width material is electronically measured; the measurements will show on a display screen. The spindle automatically adjusts itself to the correct width to maximize wood usage with tool diameter and chip removal preprogrammed.

Safety means Weinig. The Profimat 23E has been awarded the CE quality mark. It is manufactured in accordance with DIN ISO 9001 - the highest quality standard!

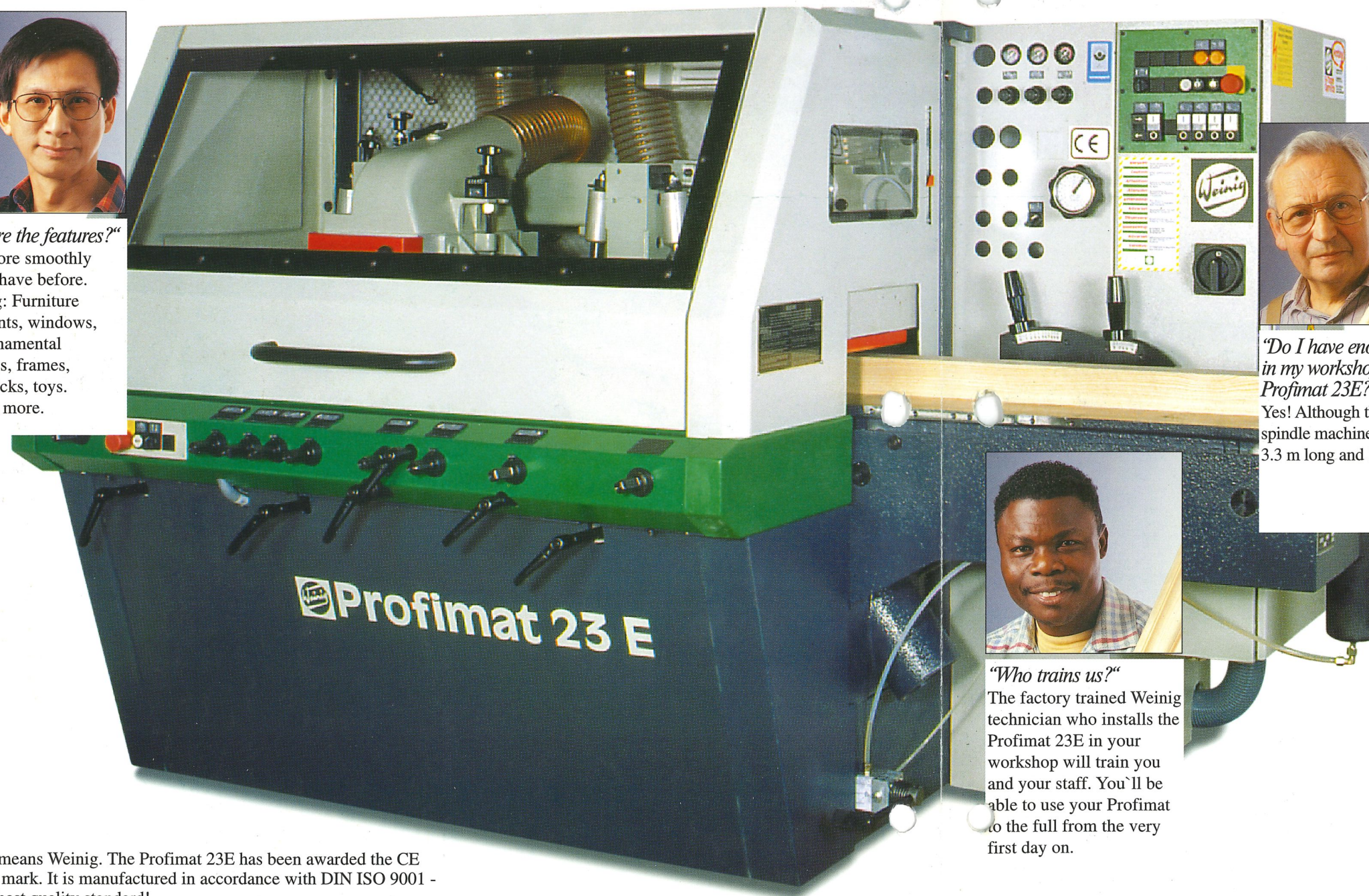

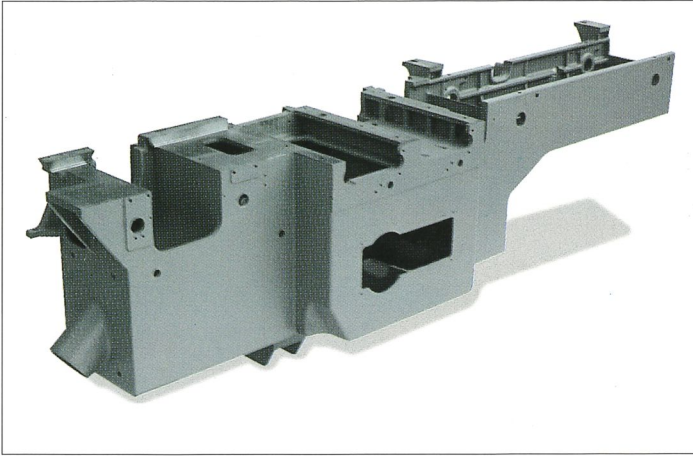

The heavy cast-iron base reduces vibrations to a minimum. This guarantees spindle stability and gives you the top notch surface quality that is demanded in today's market.

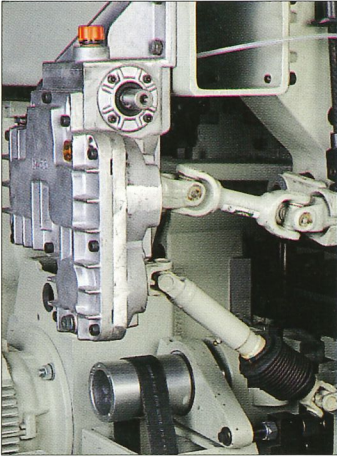

Chainless cardan drive: stronger, more precise, has a longer service life and is virtually maintenance-free.

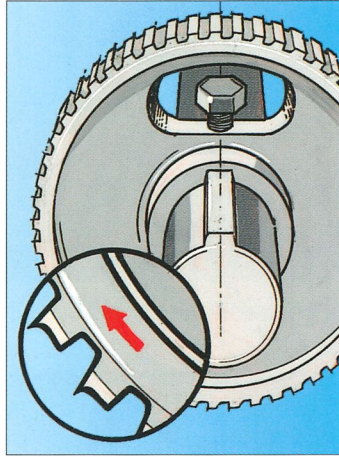

Special patented tooth design on the feed rollers is self-cleaning and provides positive feeding and reduced surface penetration. This is offered only by Weinig.

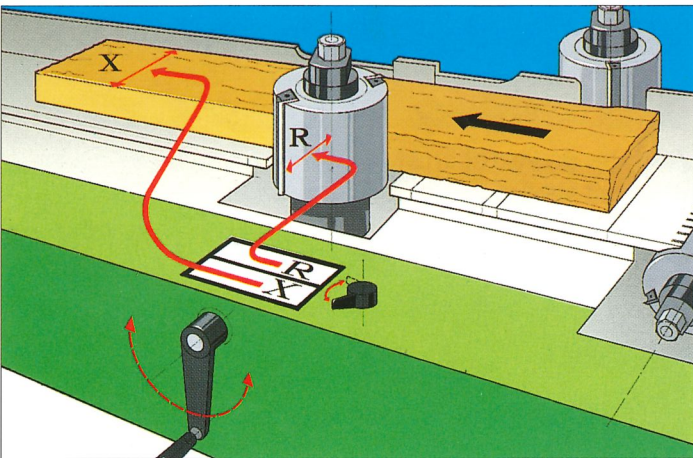

With Weinig DigiSet for the left and top spindles, the spindles are positioned by means of double-digital displays. Width and thickness of the workpieces can be read off at any time. Enormous reduction in set-up time and set-up pieces.

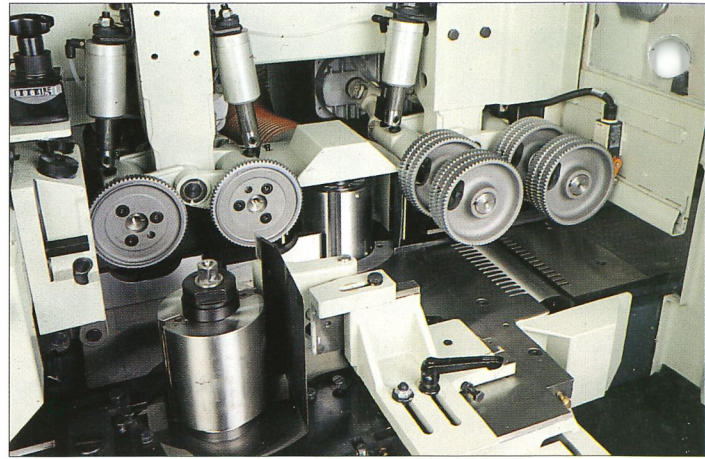

The compact spindle and drive system guarantees troublefree transportation of the workpieces. Short distance between spindles and feed rollers! The hold over rollers opposite the right spindle and the outside fence after the left spindle are all linked to the left spindle. This means no additional adjustments when the left spindle is adjusted to a new width. Pneumatic pressure for pressure rollers.

Mail it today!

**Do you have a fax machine?
Just fax the reply card to:
+49 93 41- 70 80**



Profimat 23E. The Weinig Green Class.

Made in Tauberbischofsheim designed for you.

Unbeatable precision: cast iron. There is no base construction that reduces vibrations as good as a cast-iron base, that distortion-free, that heavy. This is why the base of the Weinig

Profimat 23E is made of cast-iron. Thus it provides the perfect planing and profile surface quality like you can demand of a genuine Weinig machine.

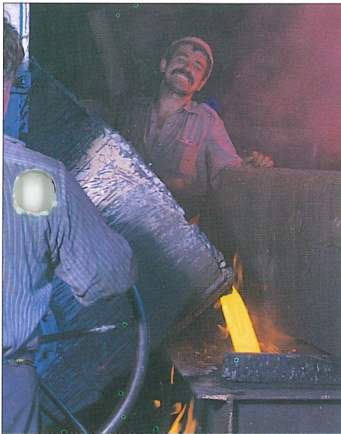

Cast iron strenght.

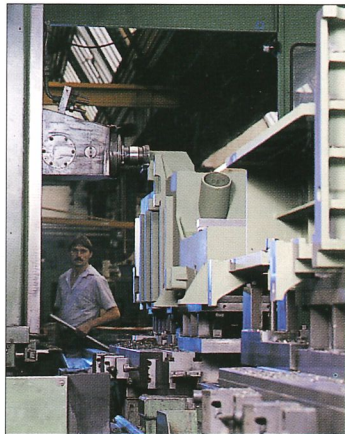

Precise manufacturing.



Precision assembly.



Now the massive feed beam is added.

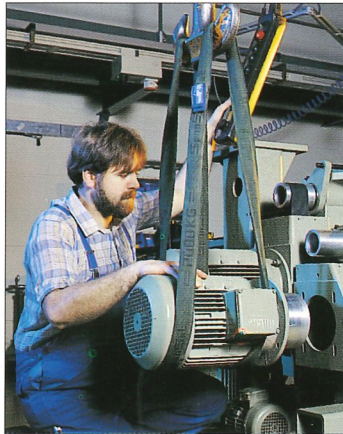

And the powerful and efficient motors.

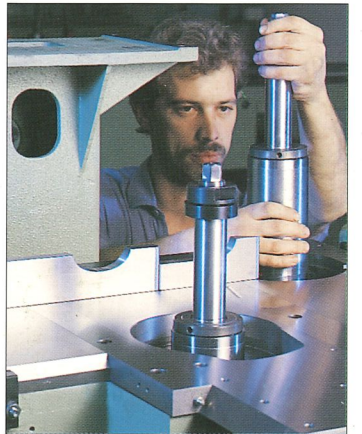

And the high-precision spindles.



The electrical cabinet, the control center of the Profimat.

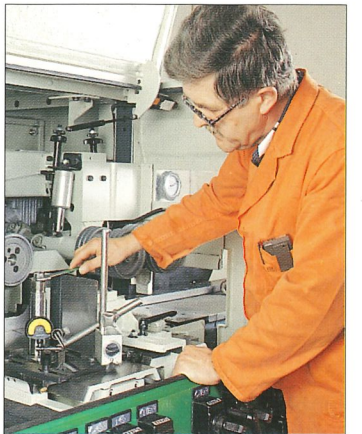

Delivery? Not before a complete test run has been carried out!

- I have some questions about the Profimat 23 E. Please have one of the Weinig experts give me a call to arrange for a visit.
- Please send literature on the more powerful Weinig Unimat the high-speed Weinig Hydromat series. (Please check!)

Company name and address:

MICHAEL WEINIG
Weinigstrasse 2/4

D-97941 Tauberbischofsheim
Fed. Rep. of Germany

Great stand- ard features

Working width (at a tool cutting circle of 125 mm)	20-230 mm
Working height (at a tool cutting circle of 125 mm)	8-120 mm
Number of spindles, min. to max.	4-6
Motor capacity, horizontal spindles	4 KW/5.5 HP
Motor capacity, vertical spindles	5.5 KW/7.5 HP
Motor capacity of the feed	2.2 KW/3 HP
Spindle speed	6,000 rpm
Spindle diameter	40 mm
Tool cutting circle, 1st bottom spindle, min. to max.	125-145 mm
Tool cutting circle, vertical spindles, min. to max.	100-200/180 mm
Tool cutting circle, horizontal spindles, min. to max.	100-200 mm
Tool cutting circle, universal spindle, min. to max.	100-200 mm
Feed speed, infinitely variable	5-24 m/min.
Feed roller diameter	140 mm
Feed roller width	2x50 mm
Width of rollers opposite left spindle	2x20 mm, 1x10 mm
Driven roller in the outfeed table, diameter	101 mm
Pneumatic pressure for feed rollers, max.	6 bar
Range of adjustment of straightening table and edge-jointing fence	10 mm
Range of adjustment of vertical spindles (axial)	40 mm
Range of adjustment of horizontal spindles (axial)	1st bottom, 5mm 1st top, 40 mm; 2nd bottom, 35 mm
Length of straightening table	2 m
Setting precision of mechanical digital readouts	0,05 mm
Full sound and safety capsule	
Fully receding, segmented chipbreaker in front of top spindle	
Motorized „up-down“ adjustment of the feed	
Lateral pressure roller opposite first right spindle	
Hardened table plate in front of first bottom spindle	
Chainless feed system	
Fence for reference engraver	

Subject to technical modifications.

Statements and illustrations in this brochure may include optional equipment that is not part of the off-the-shelf scope of supply. Safety covers partially removed for better illustration.

Useful extras.

Central location of all lubrication points
DigiSet
Up-down adjustment of infeed roller
Motorized adjustment of top spindle
ATS system
Electrical adjustment of feed speed
CAS-LogoPac system
Motor brakes
Motor increase up to 11 KW/15HP
Mobile spindle for workpieces of random widths
Groove guide for short, twisted and untrimmed workpieces
Glazing-bead saw
Air cushion in the machine table
Working width 260 mm
Working height 160 mm
Short infeed table
Chamfering unit
Straightening disks
Reinforced sound protection of the full sound, dust and safety enclosure

The spindle configurations of the Profimat 23E

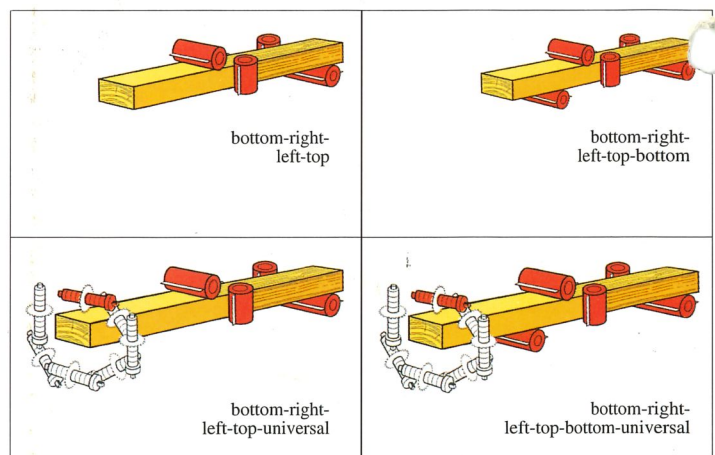

Ask Weinig.

Michael Weinig AG, Weingstrasse 2-4
D-97941 Tauberbischofsheim
Tel. (0)9341/86-0, Fax (0)9341/7080
eMail weinig@t-online.de, Internet www.weinig.com
Germany