

Feeding. Transporting. Storing.

HC WEINMANN

Our handling and storage systems
FEEDTEQ | STORETEQ | STOCKTEQ

YOUR SOLUTION

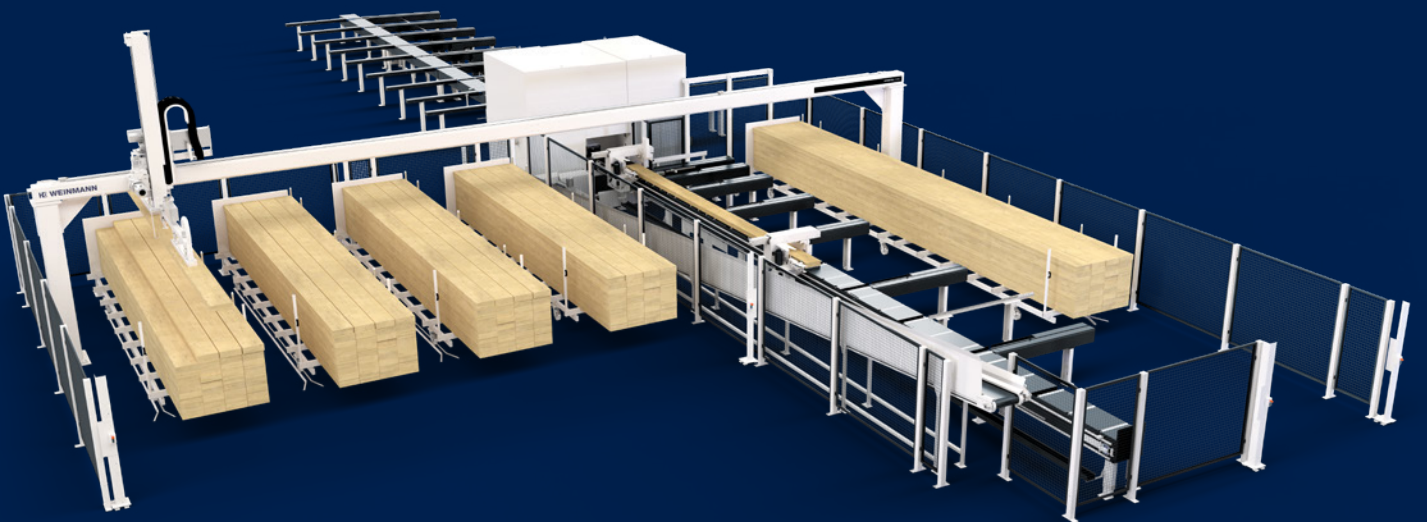



Optimized and simplified logistics

Smooth processes in the machine and systems environment are just as important for continuous production as fast and efficient machines. Our handling and storage systems optimize warehouse logistics, reduce waiting times and at the same time improve work ergonomics. Different variants are available for your respective requirements – both for individual work steps and for the entire process.

YOUR SOLUTION

[MORE: HOMAG.COM/WEINMANN](https://www.homag.com/weinmann)

CONTENTS

- 06 FEEDTEQ | STORETEQ handling systems
- 07 FEEDTEQ H-300 swing jib crane
- 08 FEEDTEQ H-500 handling portal
- 10 STORETEQ H-100|300|700 feeding portal
- 14 STOCKTEQ storage systems
- 20 Operation of up-lifting, distribution and warehouse trolley
- 21 Options for STOCKTEQ storage systems
- 22 Practical applications
- 26 Technical data and layouts for handling systems
- 28 Technical data and layouts for storage systems
- 30 Service

Efficient from the start.

On-time production of individual components, optimal use of the available space and a high degree of work ergonomics are just some of the advantages that our handling and storage systems offer. Reduced waiting times and an optimized material flow ensure maximum productivity in your production.



Unified process

- Optimized space and improved logistics
- Short throughfeed times
- High machine availability thanks to fast material provision

High work ergonomics

- Relieve the burden on employees by enabling an easier handling of heavy loads
- Simple operation and clear display
- Ergonomic working height

Versatile application options

- Automated material feeding of various raw materials such as beams and panels
- Systems for picking, transporting and loading
- Mounting of windows and doors as well as the finishing of elements

FEEDTEQ/STORETEQ handling systems

From manually operated lifting systems to fully automated portals, the FEEDTEQ and STORETEQ machines offer a broad range of options for optimized material manipulation. You will find the ideal solution for all process steps ranging from the storage of the raw material to the feeding of the machine.



STOCKTEQ storage technology

The STOCKTEQ series offers a wide range of options for transporting and storing components. The up-lifting and distribution trolleys are provided for transport between the individual workstations. The loading carriage is used for the picking and loading of the elements before the finishing work is carried out in the wall magazine.



FEEDTEQ handling systems – ergonomic and simple.

The handling systems ensure significantly improved material manipulation. With different lifting systems, you transport the required materials from the storage location to the respective machine. Different technologies are available to you depending on the material required.



Optimized material flows

- Structured production processes and short throughfeed times
- Rapid material provision
- Intelligent control system

Simplified material handling

- Beam and panel weight up to 1000 kg
- Axis speeds up to 90 m/min
- Automatic rotation/turning station (FEEDTEQ H-500)

Ergonomic working environment

- Improved working conditions due to a fast and easy handling of heavy loads
- Easy-to-use manual systems

FEEDTEQ H-300 swing jib crane

With the help of the integrated vacuum panel lifter, the operator picks up the required material from the storage location and places it on the machine. As such, panels or other materials can be transported quickly and easily by just one employee. To optimize the material paths, the swing jib crane is positioned alongside the assembly tables and the multifunction bridge.

Two variants are available:



Vacuum panel lifter

- Gentle panel handling using vacuum suction
- Adjustable to different panel sizes by means of 4 suction cups
- Panel weights up to 85 kg (optionally more)



Mobile base plate

- Optionally available: Mounting on a mobile base plate, which can be variably adjusted via a pallet truck
- Flexible design and adaptation of the material flow

FEEDTEQ H-500 handling portal

The FEEDTEQ H-500 is used in production lines. Mounted on a handling portal, the operator moves the respective integrated lifting unit freely in the X and Y directions. The areas to be traversed are freely selectable, providing a larger working area.



The correct lifting unit is available for both windows as well as panel and beam materials:



Vacuum panel lifter

With the help of the vacuum grippers, the panel materials are picked up from the collection point and transported to the element.

- Transport of different panel sizes by means of 4 suction cups
- Handling of panels weighing up to 85 kg
- The panels are easily movable via ergonomically mounted handles



Vacuum window lifter

The vacuum window lifter makes it easier to install windows

- Handling via electric chain hoist with integrated vacuum gripper
- Windows with sash and horizontal crosspieces can also be transported
- 90° rotating function
- Window weights up to 300 kg (optionally more)

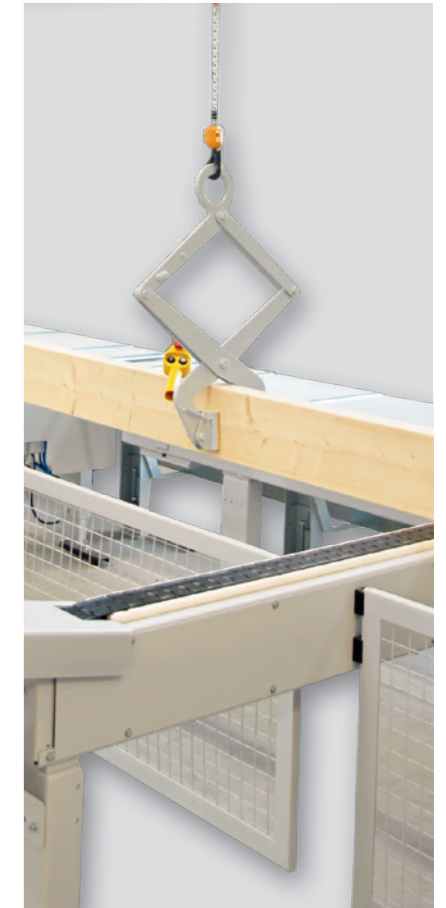

Beam lifters

With just one operator, you can easily transport your beams from the warehouse to the machine.

- Transport via easy-glide rails
- Ergonomic operation via electric chain hoist with self-locking beam gripper
- Flexible use: Transport of different beam dimensions both horizontally and vertically

STORETEQ feeding portals – the right material in the right place at the right time.

With the CNC-controlled feeding portals in the STORETEQ series, you can optimize your material flow from the very start. The required raw material (studs, beams, panels) is fed to the machine for further processing fully automatically.



Flowing production processes

- High availability thanks to a fast material supply to the respective workstations
- High-speed servo drives with up to 90 m/min
- Greater performance across the entire system
- Simplified logistics using the kanban system
- Batch size 1 production by providing all the necessary raw materials

Seamless data flow

- Direct data transfer between the feeding portal and the machine
- Automatic inventory control: Monitoring of the minimum stocks and visual display on the operating terminal if there is a shortfall
- Intelligent control system
- Integrated quality control with sorting function

Wide range of applications

- Suitable systems for the processing and creation of elements
- Handling of studs, beams and panels in differing dimensions
- Vacuum suction unit, also for wood with drying cracks
- Number of places for the raw material stacks can be optionally expanded

STORETEQ H-100 – fully automatic stud infeed for the assembly of frameworks

The STORETEQ H-100 offers you a fully automatic solution for all the material logistics required to manufacture your frameworks. The feeding portal removes the studs from the material storage location and makes them available to the framework station via an additional collection point. From there, the studs are fed via roller conveyors directly to the framework station.

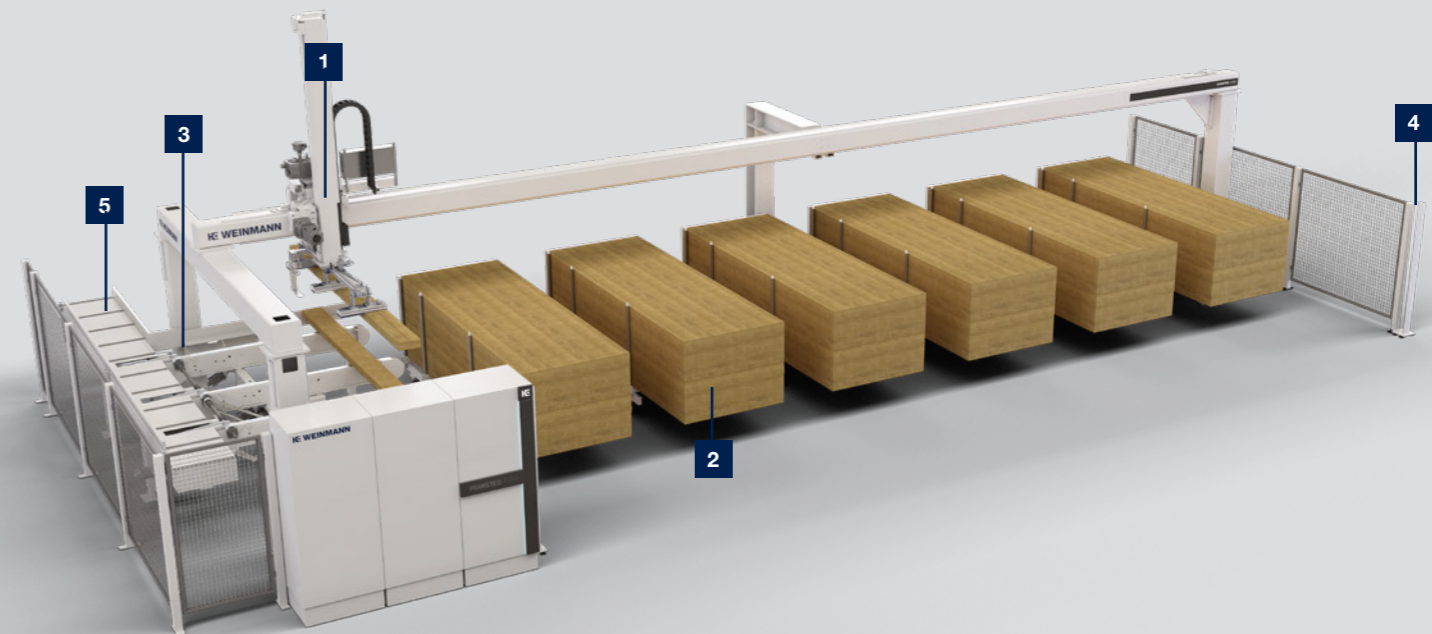

The technology:

- Simultaneous transport of several studs (up to 4 units)
- Infeed of a wide variety of wood dimensions
- Automatic separation: Feeding of the wood in the required order

How you benefit:

- High performance thanks to the automatic material feeding directly at the framework station
- The appropriate amount of material is available at the machine at the right time

- 1 Linear portal with vacuum system
- 2 Multiple storage locations
- 3 Separator
- 4 Safety system with light barriers
- 5 Roller conveyor to the framework station

STORETEQ H-300 – fully automatic feeding portal for beam processing

With the STORETEQ H-300 linear portal, the unprocessed part feed of the carpentry machine is fully automatic. With the help of the vacuum grippers, the portal picks up the beams from a stack of unprocessed parts and places them on the separator of the carpentry machine for processing.

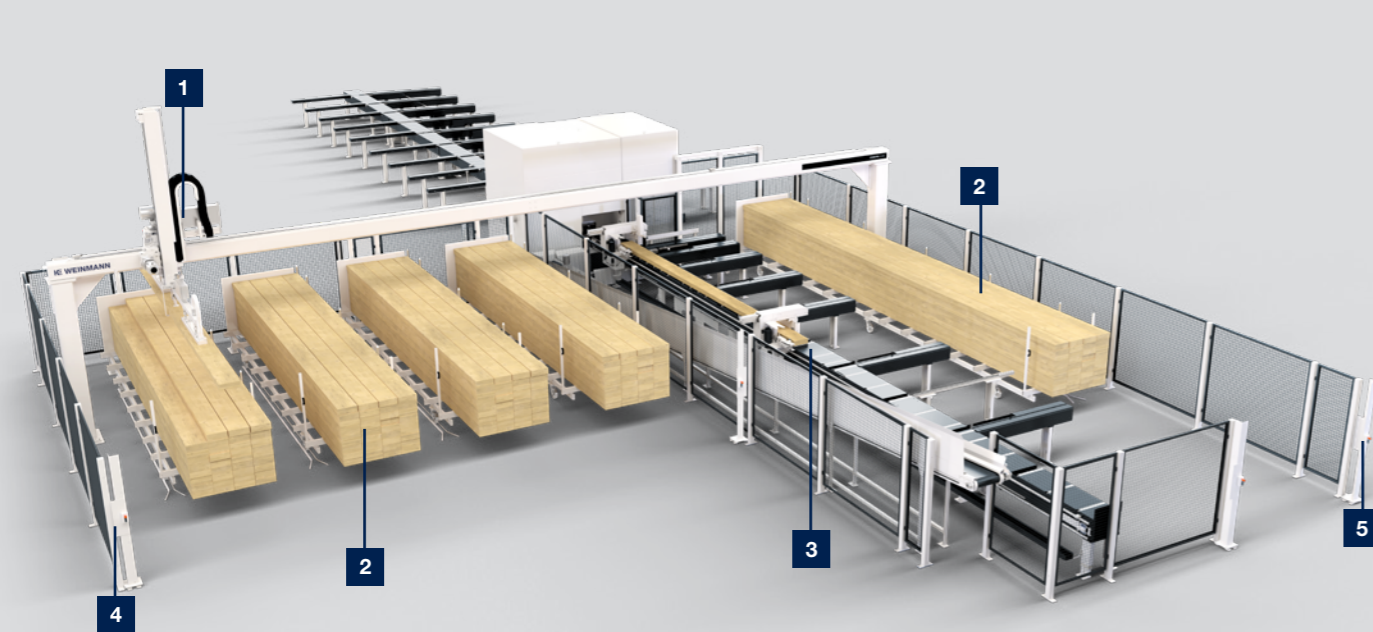

The technology:

- Feed of unprocessed parts from different stacking positions
- Different dimensions can be picked up: Wood lengths of up to 6 m are possible
- Can also be used for unstacking

How you benefit:

- Can be operated with just one person
- Significantly higher cutting performance compared to manual feeding
- Consistent process thanks to a continuous feeding of material and automatic stacking (optional)

- 1 Linear portal with vacuum system
- 2 Multiple storage locations
- 3 Processing system infeed
- 4 Safety system with light barriers
- 5 Separated safety zone

STORETEQ H-700 – individually configurable feeding portal for beams

The STORETEQ H-700 enables the feeding of the carpentry machine with beams of different lengths. The portal takes the raw material directly from the material stack and stores it in the upright position. From here, the required wood is automatically transported to the carpentry machine. The result: An efficient and flexible material and production flow.

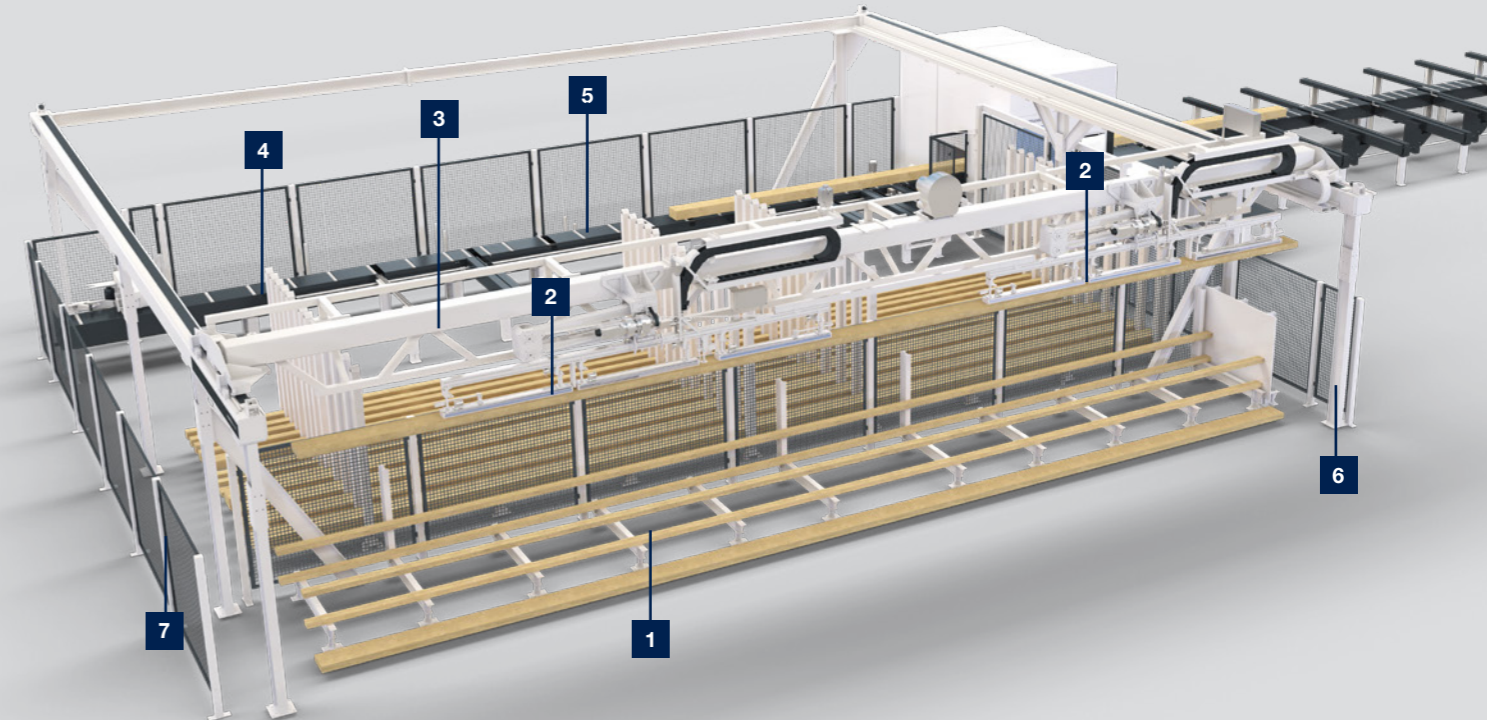

The technology:

- Automatic stacking during non-production times
- Unprocessed part lengths of between 4 and 13.7 m
- Beam weights of up to 350 kg (optionally more)
- Stacking possible
- High number of upright storage spaces (over 30 possible)

How you benefit:

- Optimal utilization of the raw wood
- Simplified logistics by providing all required wood dimensions in one system
- Considerably greater cutting performance compared to manual feeding
- The entire system can be operated with just one person

- 1 Feed position for wood packages for automatic stacking
- 2 Vacuum suction crosspieces
- 3 Linear portal Y and Z travel units
- 4 Stake magazine
- 5 Processing system infeed
- 6 Safety system with light barriers
- 7 Separated safety zone

STOCKTEQ storage technology – transport and storage made easy

With this storage technology, panels can be quickly and easily transferred to intermediate storage and picked. The systems also offer the space required for finishing work such as the application of exterior plaster or fitting windows and doors. The systems can be individually adapted to different storage facility sizes and capacities.



Short distances and high safety

- Panels protected
- Automatic positioning of the up-lifting, distribution and warehouse trolleys at the transfer stations
- Direct loading

Versatile application options

- Order picking
- Finishing panels
- Provision and loading

Ergonomic storage solutions

- Traveling operator podium and control panel on loading carriage
- Ergonomic working height
- Easy movement even of heavy panels

STOCKTEQ U-330 | U-530 Up-lifting and distribution trolleys

The up-lifting and distribution trolleys are mainly used in production lines for the transport of wall panels between different workstations as well as their storage. For this purpose, the panels are placed on trolleys or rollers, transported to the appropriate wall track and then manually pushed out of the up-lifting and distribution trolleys and into the storage location.



How you benefit:

- Horizontal transport of the wall panels
- Traversing operation in longitudinal and transverse direction enables an optimized logistics process even across large distances
- Utmost safety at work thanks to the secure transport of panels and extensive safety equipment
- Easy and safe installation of the panels by means of the hydraulic swivel device
- Transport of the installed panels via wall trolleys or loose rollers (individually selectable)
- Networking with the entire production line and control via PLC
- Control is either directly on the lifting-up and distribution trolleys or via decentralized control points
- Fully automatic procedure possible as an option

STOCKTEQ V-300 | V-500 wall magazine

The STOCKTEQ V-300/V-500 offers the right solution for the intermediate storage of the wall panels. In the wall magazine, the panels are temporarily stored and transported standing before loading or during the production process.

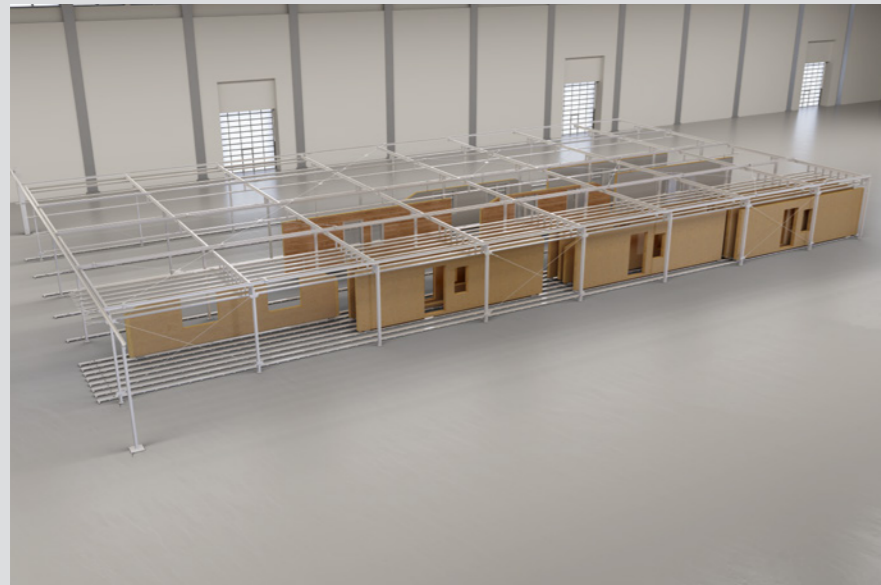

How you benefit:

- Production-optimized process: Intermediate storage and loading of the panels in the required sequence
- Additional work, such as plastering or window installation, can be performed in the wall magazine
- Damage-free transport and storage
- Comprehensive safety system with protected wall tracks

STOCKTEQ D-300 | D-500 distribution and warehouse trolley

This system is used for all the tasks related to the logistics of the manufactured wall panels. The wall panels are temporarily stored vertically according to the loading classification. The operator manually moves the distribution trolley to the desired wall track and pushes the wall into the distribution trolley. For easy handling of the elements, a traveling operator podium is installed. From this position, the operator attaches the panel directly to the distribution trolley and moves the respective wall panel to the desired position in the wall magazine.



How you benefit:

- Flexible material transport between individual workstations and storage locations
- Positioning of the trolley at the wall tracks via PLC-controlled laser measuring systems
- Utmost safety at work

STOCKTEQ V-330 | V-530 window installation track

The window installation track offers the option to install windows and doors in the wall panels. The installation is carried out vertically with the help of a vacuum lift.



How you benefit:

- Panels are accessible from both sides
- Ergonomic working with vacuum lift
- Installation of the windows without having to realign the panels

STOCKTEQ V-100 stake magazine

The finished panels are transported into the upright stores with the overhead crane and placed between the uprights. Until the final loading, the panels are temporarily stored here. This solution is especially tailored for small and medium-sized businesses.



How you benefit:

- Storage capacity of up to 100 m wall panels with 6 supports and 80 uprights
- Easy loading and removal using the overhead crane
- Flexible construction with supports recessed in the floor and narrow grid holes
- When not in use, the surface can be used for other work
- Plug-in upright system for easy adaptation to the elements
- The uprights prevent the walls from falling to the side for utmost safety at work

Sophisticated logistics for an optimized process

Our integrated storage system offers you a continuous flow of materials – from the transport of the manufactured elements through finishing work and on to the intermediate storage and loading of the elements. You manufacture your panels in a production-optimized manner and load them with the help of the storage technology in the appropriate assembly sequence.

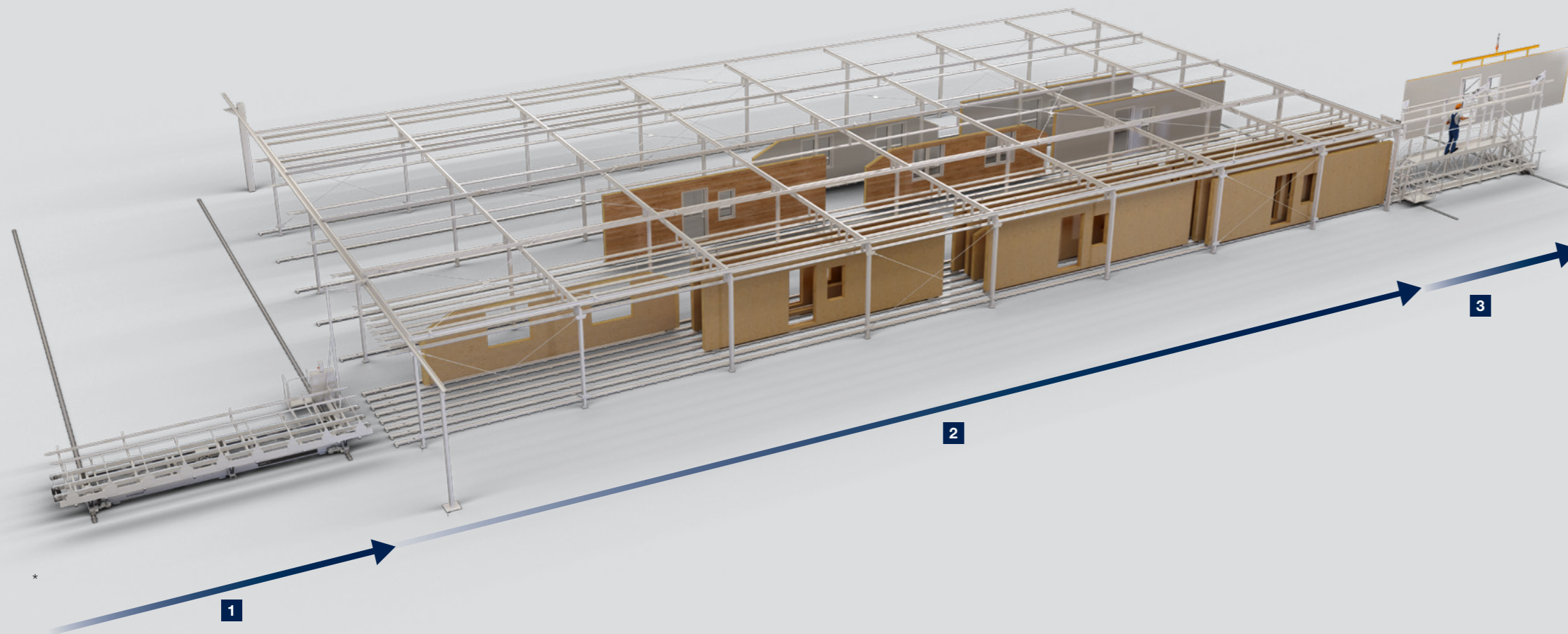

1 Order picking

With the distribution trolley you transport your elements from the production line directly to the wall magazine, to the window installation or to other processing stations.

2 Storage

The finished elements are stored in the wall magazine. Finishing work such as fitting the windows, plastering or applying the formwork can also be carried out in the wall magazine.

3 Loading

For shipping, the respective element is made available from the wall magazine and loaded onto the truck with the aid of the loading carriage.

* illustration shows standing system with trolley.

Two variants are available:

▪ Standing system

The wall panels are transported upright on trolleys or rollers.



▪ Suspended system

The panels are transported by an overhead conveying system with a guide carriage.



Operation of the up-lifting, distribution and warehouse trolley

These trolleys are equipped with our proven control system from wall and ceiling production. This enables you to work with just one system. All the necessary functions are clearly integrated on the traveling operator podium.



Operator podium with user-friendly functions



Traveling operator podium

Automatic control (optional)

- All positions for the transport and wall magazine systems are stored in the PLC and are controlled directly
- The position is detected by a laser distance sensor. No additional installations are required on the floor of the warehouse and the driving surface can be used by vehicles without any problems. The storage positions can be changed or extended at any time.
- Safety technology enables the independent operation of the set-up and distribution trolleys



Fixed control station



powerTouch operation

- Direct and efficient operation, up to 30% faster
- More informative and more transparent thanks to additional information and live preview images instead of program icons

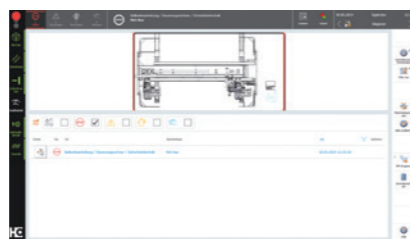

woodScout diagnostic system

- Display of warnings and errors for diagnostic purposes
- Systematic troubleshooting for increased machine availability

Options for STOCKTEQ storage systems – lots of possibilities

The various systems can be optimally adapted to your requirements. A variety of options are available for this purpose.



Guides for wall panels

The panels are guided into the wall magazine via bolts and rods and secured against falling out. Optionally, the rods can be screwed to the side of the elements or plugged onto the bolts.



Safety interlock for wall magazine

Ensures safety when moving panels from the wall magazine into the distribution trolley and prevents the panels from being accidentally pushed out of the magazine.



Upright wall trolley

Manual transport of upright wall panels via wall trolleys that are guided on rails.

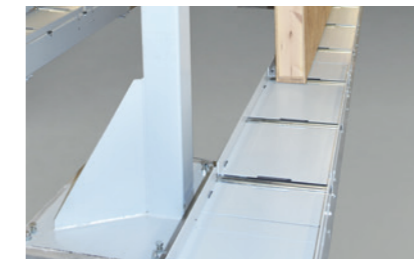

Roller conveyor

Allows the panels to be moved easily without the need for a wall trolley.



Pneumatically opening top guide

Once approved by the operator, this unit can remove the wall panels from the distribution trolley by means of the overhead crane.

Configuration options

The choice is yours. The available options provide you with a wide range of possibilities to adapt your storage systems to your production requirements. In the table you will find an overview of the options that are possible in the respective systems.

	STOCKTEQ U-330/U-530	STOCKTEQ V-300	STOCKTEQ V-500	STOCKTEQ V-330	STOCKTEQ V-530	STOCKTEQ D-300	STOCKTEQ D-500
Guides for wall panels	✓	✓	✓	✓	✓	✓	✓
Wall trolley – upright version	✓	✓		✓		✓	
Roller conveyor	✓		✓		✓		
Pneumatically opening top guide		✓	✓			✓	✓
Safety interlock for wall panels	✓	✓	✓	✓	✓	✓	✓

The handling and storage systems in practical use



Powerful and flexible
Processing system with feeding portal and integrated storage



- Integrated storage
- Storage of different wood dimensions
- Special scissor lifting system for lower warehouse heights

Material handling and processing in stacks
Material feed with automatic stacking for efficient cutting



- Feeding with different materials: Solid wood and I-beams
- Various collection and unloading points
- Intelligent control system: The portal detects each unloading position fully automatically
- Fully automatic destacking function



Versatile stud feeding
Handling portal for stud feeding with integrated sorting unit

- High flexibility: Eleven stacking positions
- Automatic package delivery
- Automatic stacked wood removal
- Integrated quality control



Efficient panel handling
Fully automatic feeding portal for panel materials

- A wide variety of panel materials and sizes
- Precise positioning of the panels on the element
- Process safety increases performance and ensures utmost precision



Just-in-time stud feeding
Framework station with integrated feeding portal for six stud cross-sections

- High output for stud feeding: Simultaneous collection of up to four studs
- Increased and consistent overall performance
- Automatic detection of the fill level of the material trolley



Optimized storage – optimized production
Integrated storage system

- Perform additional work such as plastering or window installation
- Production-optimized process: Intermediate storage and loading of the panels in the required sequence with simultaneous production-optimized manufacturing
- Damage-free transport and storage

Technical data for FEEDTEQ | STORETEQ handling systems

HANDLING SYSTEMS	FEEDTEQ H-300	FEEDTEQ H-500
MACHINE DIMENSIONS		
Lift height (m)	1.74	
Handling range (m)	6 x 3.2 / 12 x 3.2	
Gripping technology	Vacuum pump	
Portal length (m)	5 / 6 / 7	-
PRODUCT DIMENSIONS		
Max. panel weight (kg)	85*	
Max. panel size (m)	1.25 x 3.2*	

FEEDING PORTAL	STORETEQ H-100	STORETEQ H-300	STORETEQ H-700
MACHINE DIMENSIONS			
Overall height (depending on version) (m)	4.2		4.3
Number beam pre-storage compartments	4-6		10-40 (customer specific)
Gripping technology	Vakuümflächensauger		
PRODUCT DIMENSIONS			
Max. panel weight (kg)		85*	
Max. beam weight (kg)		85*	360*
Max. panel size (m)		1.25 x 3.2	
Beam length max. (m)	3.8	6	13.7

* further configurations possible on request.

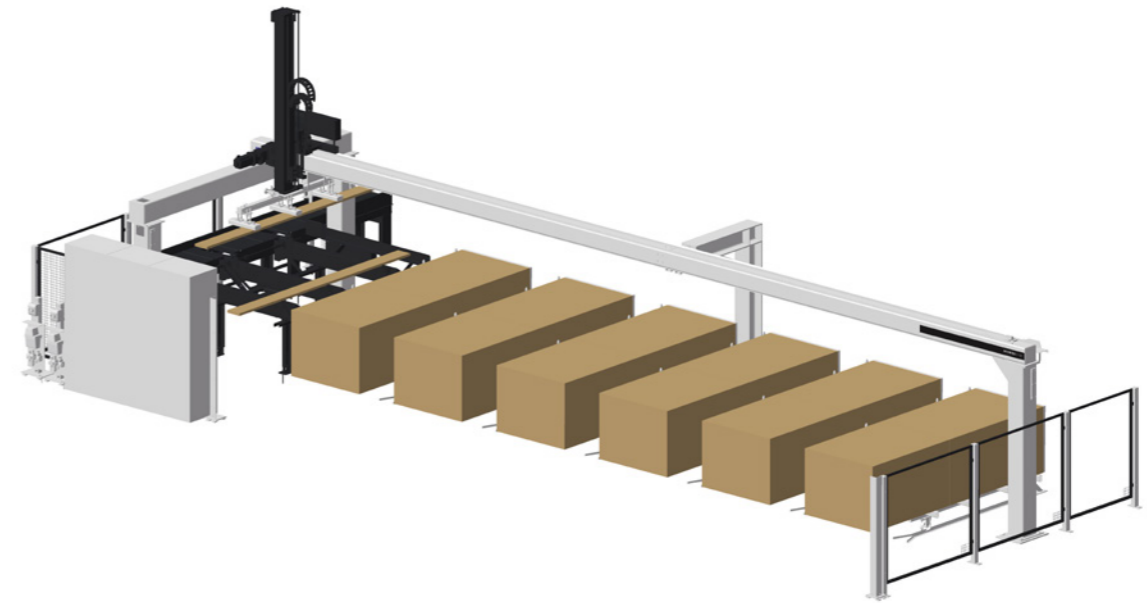

STORETEQ H-100

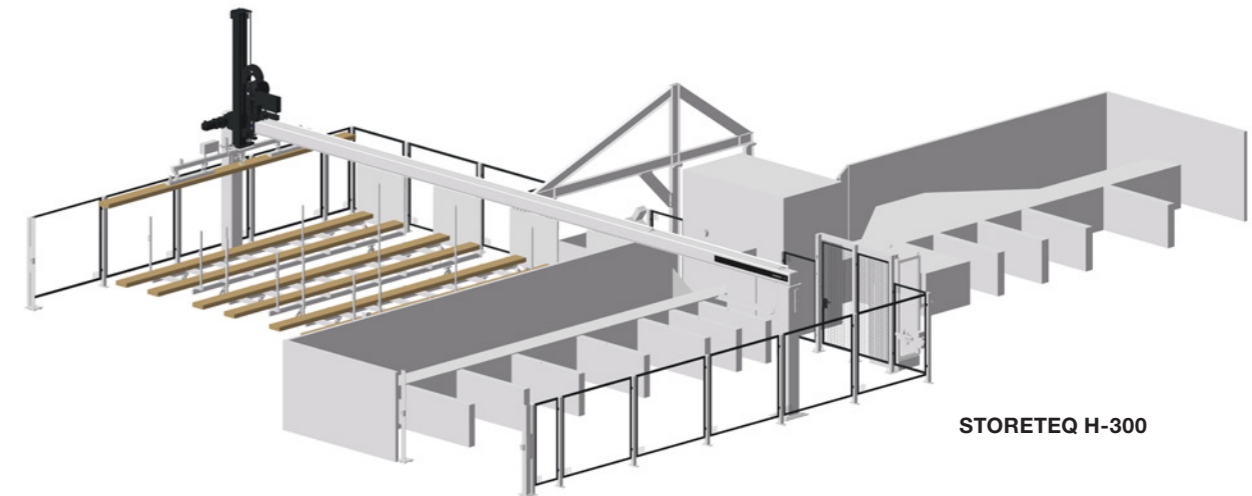

STORETEQ H-300

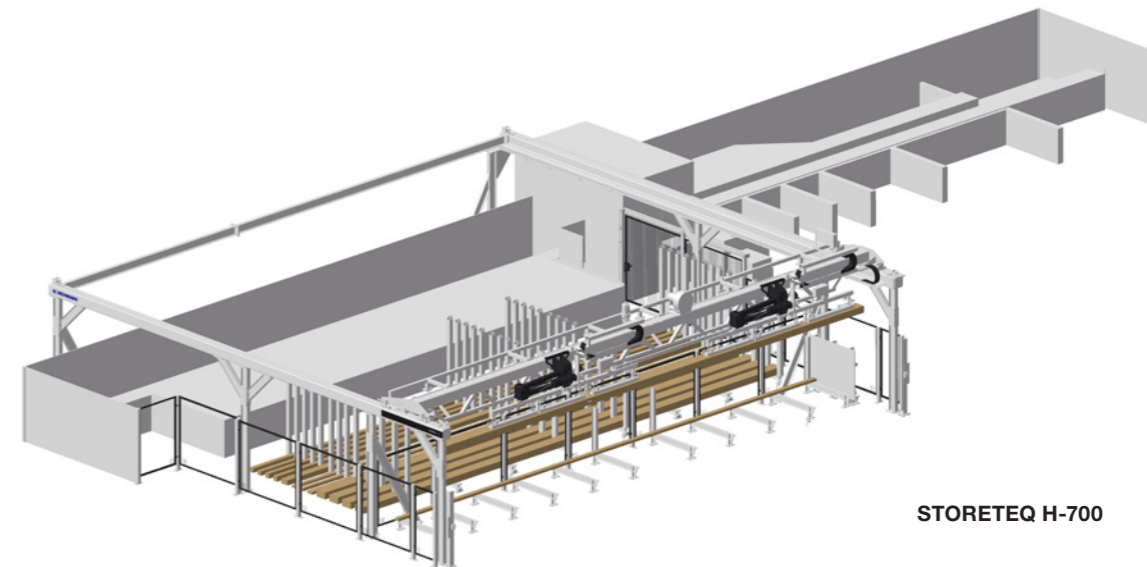

STORETEQ H-700



FEEDTEQ H-300

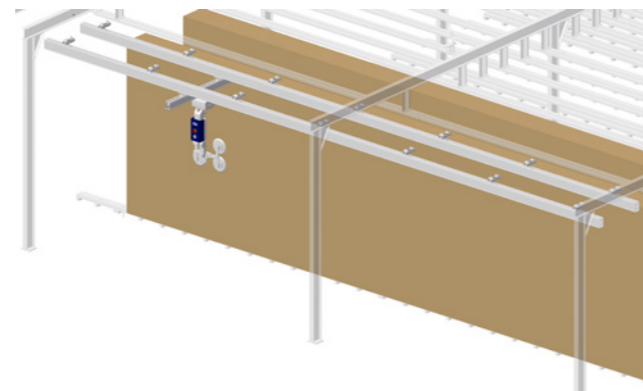

FEEDTEQ H-500

Technical data for STOCKTEQ storage systems

STORAGE SYSTEMS	STOCKTEQ U-330/530	STOCKTEQ D-300/500	STOCKTEQ V-300/500/100/330/530
PRODUCT DIMENSIONS			
Min. length (m)	0.5	-	-
Max. length (m)	6 / 8 / 10 / 12	-	customer specific
Min. width (mm)	-	75	-
Max. width (mm)	-	500	-
Min. height (mm)	-	1200	-
Max. height (mm)	-	3200 / 3810	-
Special heights (mm)	-	customer specific	-
Max. element weight (kg)	-	3500 *	-
FURTHER INFORMATION			
Magazine capacity (m)	-	-	customer specific (exception STOCKTEQ V-100: max approx. 100)
Wall clearance in magazine (mm)	-	-	500*

* further configurations possible on request.

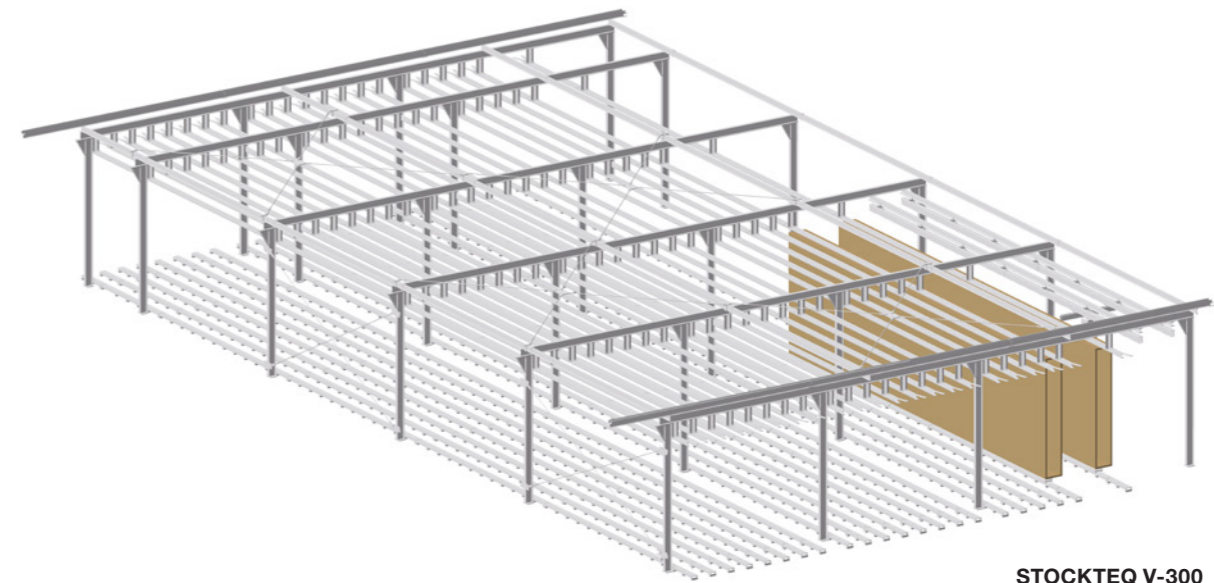

STOCKTEQ V-300

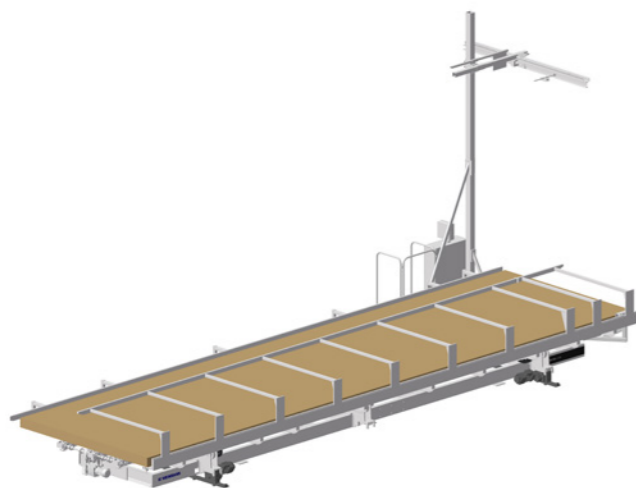

STOCKTEQ U-530

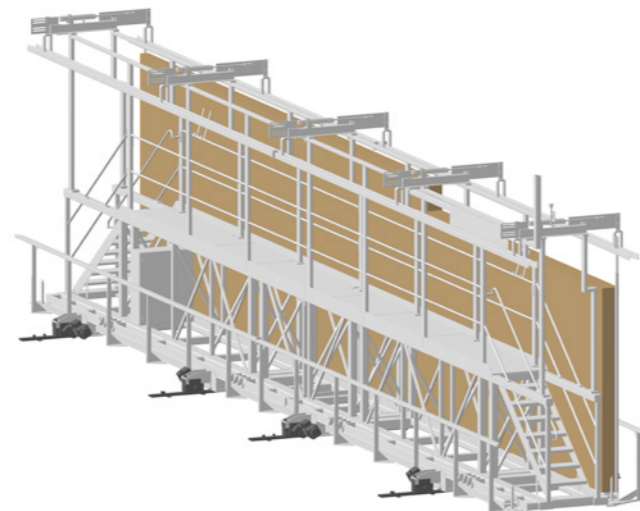

STOCKTEQ D-300

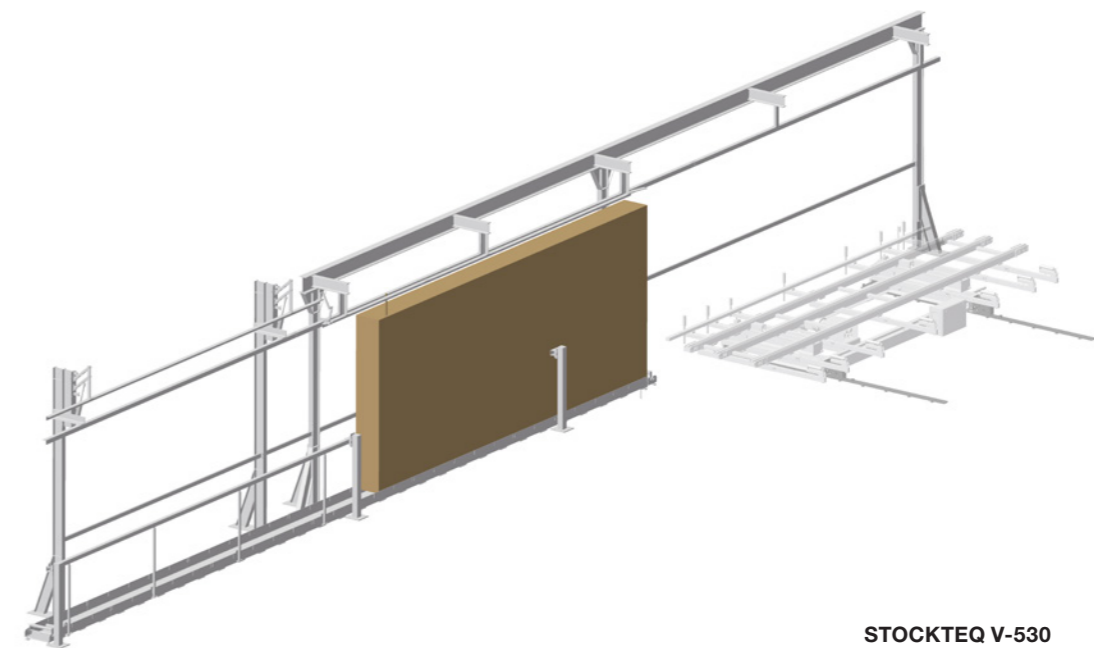

STOCKTEQ V-530

HC LIFE CYCLE SERVICES

Optimal service and individual consultations are included in the purchase of our machines. We support you with service innovations and products which are especially tailored to your requirements. With short response times and fast

customer solutions we guarantee consistently high availability and economical production – over the entire life cycle of your machine.



REMOTE SERVICE

- Hotline support via remote diagnosis by our trained experts regarding control, mechanics and process technology. Thus, more than 90% less on-site service required and consequently a faster solution for you!
- The ServiceBoard App helps to solve tasks in a fast, simple and concrete way. This is achieved by mobile live video diagnosis, automatic sending of service requests or the online spare parts catalog eParts.



SPARE PARTS SERVICE

- High spare parts availability and fast delivery.
- Ensuring quality by predefined spare parts and wear parts kits, comprising original spare parts.
- Identify and inquire for spare parts online under www.eParts.de 24/7, or buy even faster and more comfortably in the new HOMAG Webshop eCommerce.



MODERNIZATION

- Keep your machinery up to date and increase your productivity as well as your product quality. This is how you can meet tomorrow's requirements today!
- We support you with upgrades, modernization as well as individual consultancy and developments.



DIGITAL SERVICES

- ISN (intelliServiceNet) – The new remote service solution of the future! Fast restart of production because the remote service employee has extensive access to relevant physical data.
- intelliAdvice App – provides help for self-help. The preventive solutions proposed in the new App are the combination of our experiences and existing machine data.



SOFTWARE

- Telephone support and consultancy through software support.
- machinery with intelligent software solutions ranging from construction to production.



FIELD SERVICE

- Increased machine availability and product quality by certified service staff.
- Regular checks through maintenance / inspection guarantee the highest quality of your products.
- We offer you the highest availability of technicians in order to reduce downtimes in case of unpredictable troubles.



TRAINING

- Thanks to training perfectly suited to your requirements, your machine operators can optimally operate and maintain the WEINMANN machines.
- The training also include customer-specific training documents with exercises proven in practice.
- Online training and webinars. Learn without traveling, meet your trainer in the digital classroom.



For you more than...

1.350
service employees worldwide

92%
less on-site service thanks to successful remote diagnosis

5.000
customer training sessions per / year

150.000
machines, all electronically documented in 28 different languages – in eParts

WEINMANN Holzbausystemtechnik GmbH

info@weinmann-partner.de
www.homag.com/weinmann

YOUR SOLUTION

