

The WEIMA Universal Shredder

WLK – Series



Technical data and dimensions

Type	WLK 4	WLK 4 S	WLK 6 S	WLK 8	WLK 10	WLK 12	WLK 14	WLK 15	WLK 18	WLK 20	WLK 25
1. Technical data:											
Feed opening (mm)	600 x 800	600 x 900	800 x 1.200	1.000 - 1.000	1.000x1.200	1.200x1.200	1.500x1.200	1.500x1.500	1.800x1.500	2.000x1.500	2.500x1.500
Hopper volume (m³)	0,5	0,6	1,1	1,0	1,3	1,6	2,0	2,5	3,4	4	4,8
Rotor-Ø (mm)	252	368	368	252	368	368	368	368	368	368	368
Rotor speed (UpM)	ca. 80	ca. 85	ca. 85	ca. 80	ca. 85	ca. 85	ca. 85	ca. 85	ca. 85	ca. 85	ca. 85
Drive capacity (kW)	11/15/18,5/22	22/30/37	30/37/45	22/30/37/45	37/45/55	37/45/55	30/37/45/55/75	45/55/75/90	75/90/2x55/2x75	75/90/2x55/2x75	75/90/2x55/2x75
Knives (1/2 rows)	14/28	17/30	23/42	27/54	28/52	34/64	43/82	43/82	52/100	57/110	68/136
Screen size (mm)	15-100	15-100	15-100	15-100	15-100	15-100	15-100	15-100	15-100	15-100	15-100
Connection-Ø (mm)	160	200	200	200	200	200	250	250	250	250	250
Rotor-System	V-Rotor- or Flat-Rotor-System from WEIMA / Concave knives - 4 times reversible – dependent on material and screen size 40 x 40 / 60 x 60 / 80 x 80 mm										
Weight (approx. kg)*	1.600	2.000	2.900	2.500	3.500	4.300	4.500	5.000	7.000	8.000	9.500
2. Dimensions:											
Dimension A (mm)	1.300	1.400	1.600	1.800	1.930	2.130	2.430	2.430	2.900	3.100	3.600
Dimension B (mm)	600	600	800	1.000	1.000	1.200	1.500	1.500	1.800	2.000	2.500
Dimension C (mm)	800	900	1.200	1.000	1.200	1.200	1.200	1.500	1.500	1.500	1.500
Dimension D (mm)	1.800	1.900	2.100	2.000	2.100	2.100	2.100	2.700	2.700	2.700	2.700
Dimension E (mm)	1.640	1.785	1.880	1.640	1.880	1.880	1.880	1.880	2.060	2.060	2.060
Dimension F (mm)	1.075	1.160	1.160	1.075	1.160	1.160	1.160	1.160	1.160	1.160	1.160
Dimension G (mm)	520	460	760	720	760	760	760	1.060	1.060	1.060	1.060
Dimension H (mm)	740	900	995	740	995	995	995	995	1.175	1.175	1.175
Dimension I (mm)	355	405	405	355	405	405	405	405	455	455	455
Dimension J (mm)	300	400	400	300	400	400	400	400	400	400	400
Dimension K (mm)	540	1.025	1.025	540	1.025	1.025	1.025	1.025	1.025	1.025	1.025
Dimension L (mm)	---	---	2.420	2.100	2.420	2.420	2.420	3.000	3.000	3.000	3.000

* Weights depending on equipment and drive capacity.

Single-Shaft-Shredder WLK 4 S - WLK 25 Recycling Technology for your applications...

The WLK-Series is designed for the shredding of recyclable materials. Precision manufacturing and Technical Innovation combined with our Experience provides a Cost Effective Solution.

Our extensive machine range and options ensure a suitable solution for almost all applications. The WLK-Series – for the shredding of rigid plastics, film, fibre materials, textiles, paper, cardboards and rubber...

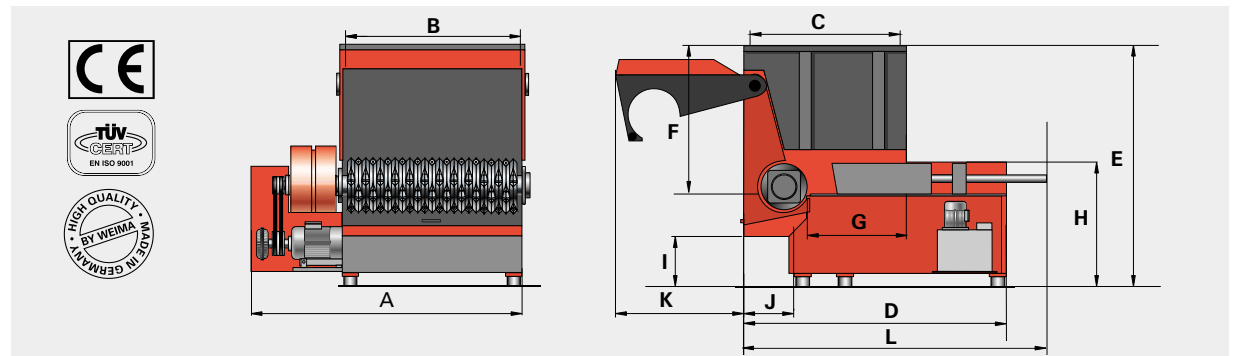

WEIMA Maschinenbau GmbH · Gewerbegebiet Bustadt · D - 74360 Ilsfeld (Germany) · Phone: +49 (0) 70 62 / 95 70 - 0 · Fax: +49 (0) 70 62 / 95 70 - 92 · Internet: www.weima.com · E-Mail: info@weima.com

Advanced technology for size reduction

WEIMA shredders for plastics and recycling

Series WLK Light to medium demand models



WLK 4 S · WLK 6 S · WLK 10

Performance profile

The WLK series of universal shredders are suitable for processing almost all plastics, in particular hard and resistant materials. The machines will shred production waste, pipes, automotive parts, blow-moulded materials such as for example PET bottles, PE/PP bottles, containers or buckets without problems, and also paper, cardboard, light metals.

Various sizes and different versions guarantee optimum adjustment for every application.

Options such as the patented V-rotor with adjustable counter knife so called Supercut allow for first-class shredding results. WLK shredders can be belt or manually fed or loaded by fork-lift trucks. They are also ideal as preliminary shredders integrated into a two-stage operation.

The WLK Series - an overview

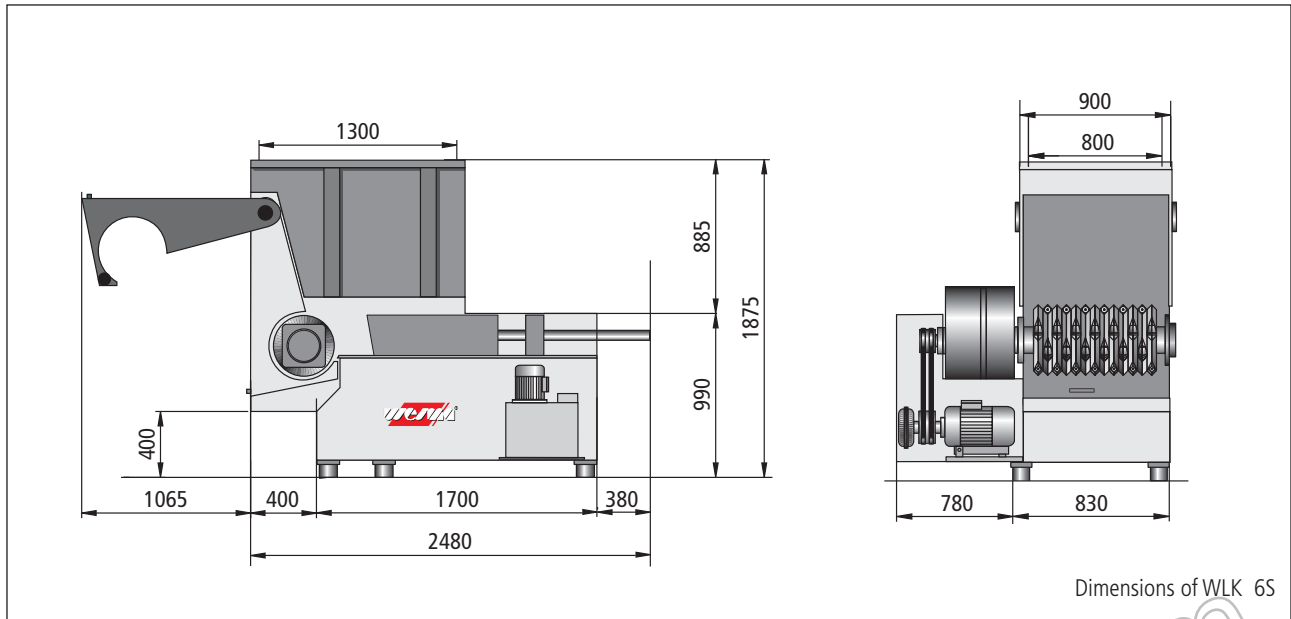

SPECIFICATIONS

	WLK 4 S	WLK 6 S	WLK 10
Number of knives	(17) 30	(23) 42	(28) 52
Feed opening (mm)	600 x 900	800 x 1.200	1.000 x 1.200
Hopper capacity (m ³)	0,6	1,1	1,3
Rotor diameter (mm)	368	368	368
Rotor speed (rpm) approx.	85	85	85
Motor performance (kW)	30/37	30/37/45/55	37/45/55/75
Screen perforation (mm)	15-100	15-100	15-100
Weight (kg) approx.*	2.000	2.900	3.500

*This may vary according to equipment and drive performance of the machine.

EQUIPMENT

Standard series equipment

- patented Y-rotor for optimum even cutting geometry
- concave-ground cutting knives
- hydraulic horizontal feed ram, load-sensitive control
- moveable screen basket for quick rotor access and screen changing
- low maintenance, offset and sealed rotor bearings
- memory-programmable control (PLC)

Options

- E-rotor with welded-on or screwed-on knife holders
- Supercut for precise adjustment of cutting gap
- RAM extra options: turbo-hydraulics, pusher segmented feed, ram comb
- pipe spacer funnel for controlled material feed of large parts
- rotor cooling
- hydraulic oil and gearbox oil cooling
- Hardox coating for rotor

Drive

WLK shredders are available with the option of mechanical or hydraulic drive. Options for increased safety: gearbox limit switch, reverse counter, hydrodynamic clutch, safety switch.