

# Active 400

sliding table circular saw



 **BIESSE**

When competitiveness  
means long term  
reliability

Active 4

Made **In** Biesse

## The market demands

a change in manufacturing processes that enables companies to **accept the largest possible number of orders**. This is coupled with the need to maintain high quality standards whilst offering product customisation with quick and defined delivery times.

## Biesse meets these requirements

with **technological solutions** that highlight and support technical expertise as well as process and material knowledge.

**Active 400** is the sliding table circular saw that provides the highest levels of quality, precision and accuracy. It is the ideal machine for craftsmen as well as for finishing production areas of industries. It is suitable to cut solid wood, plywood, MDF board, particle board as well as laminated boards.

- ✓ **High sizing precision**
- ✓ **Maximum result for every needs**
- ✓ **Great stability thanks to heavy duty structure**
- ✓ **Easy panel handling and simple adjustments**
- ✓ **User friendly machine and simple controls**

Accuracy  
and reliability



Active 400  
sliding table circular saw



# High sizing precision

Due to its rigidity, this saw carriage is very stable.

The saw carriage is divided into three sections:

- ▶ Main Saw Unit
- ▶ Scoring Unit
- ▶ Saw Carrying Structure.

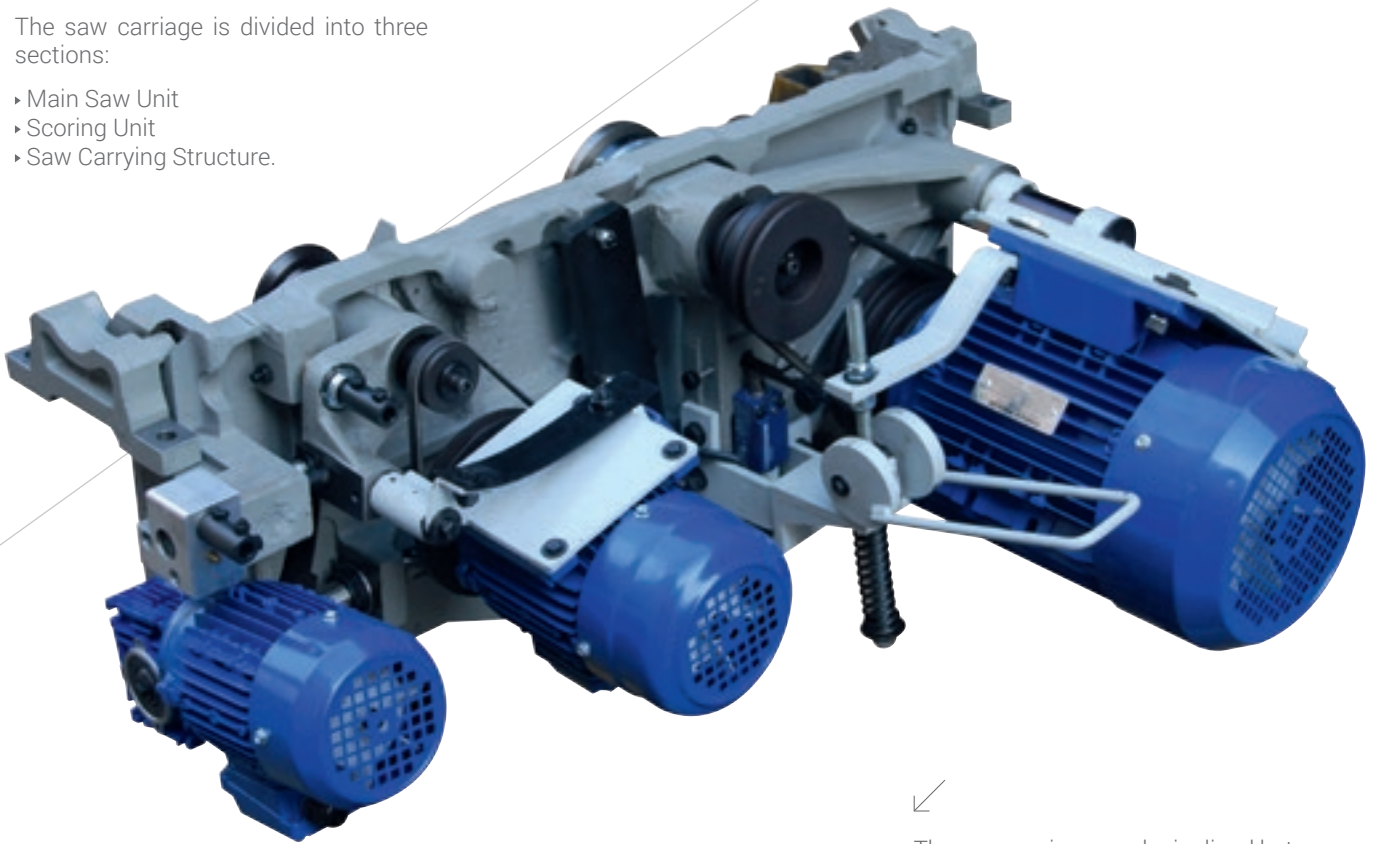

The saw carriage can be inclined between 0-45 degrees to adapt to different cutting requirements.

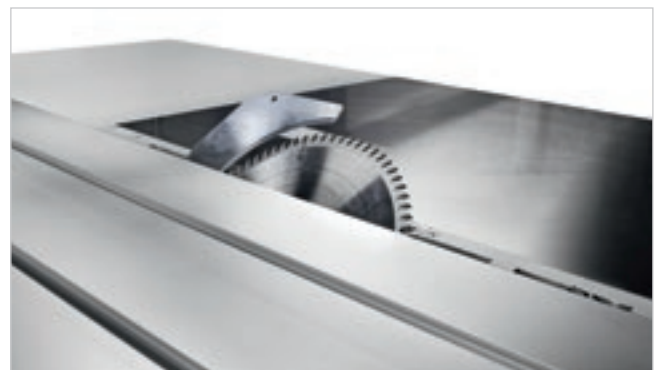

The sliding carriage is divided into two parts: the sliding base and the sliding table. Both are formed by high quality anodized aluminum and processed by high precision CNC working centre. This guarantees the sliding carriage reliability and accuracy.

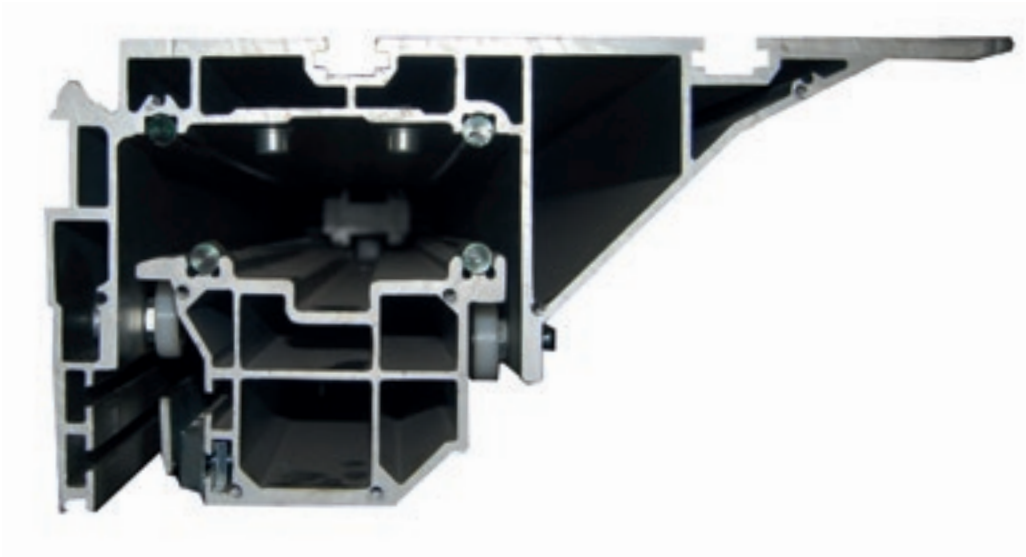

The sliding table can be locked at any position.

# Maximum result for every need

**Wide sliding table ensures stability and precise cuts and repeatability.**



## **Angle adjustment of cross cut fence**

The cross-cut fence can be adjusted with turning angle, the range of adjustment:  $\pm 45^\circ$ .







### Work piece holder

Removable type work piece holder can be mounted freely on the sliding table according to the materials to be sized.



The sturdy **cross cut fence** ensures precise cuts. The stops slide easily beside the scale that is tilted for better viewing. This fence can be repositioned for making mitre cuts also.



### Extension Cross Cut Fence

The fence is designed with "slant" surfaces that would minimize the chance of scratching the workpiece. Maximum length 3200 mm.

# Great stability

## Sliding Block for Rip Cut Fence

The sliding block can slide freely on the round bar guide and locked with the handle.

Its position can be finely adjusted with a tuning knob with assistance of a high precision ruler.



# Easy panel handling and simple adjustments

**Simple controls make this machine user friendly**



## Fast and easy external adjustment of saw blades

- ▶ Hand wheel for the adjusting of saw blades inclination with angle indicator.
- ▶ Fine adjustment devices for setting the scoring blade up/down and left/right positions.
- ▶ Electrical adjustment of Saw blade height.



Safety cover to protect the operator from the saw blades (CE version).



NCE cover head saw blade.



# Service & Parts

Direct, seamless co-ordination of service requests between Service and Parts.  
Support for Key Customers by dedicated Biesse personnel, either in-house and/or at the customer's site.

## Biesse Service

- ✓ Machine and system installation and commissioning.
- ✓ Training centre dedicated to Biesse Field engineers, subsidiary and dealer personnel; client training directly at client's site.
- ✓ Overhaul, upgrade, repair and maintenance.
- ✓ Remote troubleshooting and diagnostics.
- ✓ Software upgrade.

500 / Biesse Field engineers in Italy and worldwide.

50 / Biesse engineers manning a Teleservice Centre.

550 / Certified Dealer engineers.

120 / Training courses in a variety of languages every year.

The Biesse Group promotes, nurtures and develops close and constructive relationships with customers in order to better understand their needs and improve its products and after-sales service through two dedicated areas: Biesse Service and Biesse Parts.

With its global network and highly specialised team, it offers technical service and machine/component spares anywhere in the world on-site and 24/7 on-line.



## Biesse Parts

- ✓ Original Biesse spares and spare kits customised for different machine models.
- ✓ Spare part identification support.
- ✓ Offices of DHL, UPS and GLS logistics partners located within the Biesse spare part warehouse, with multiple daily pick-ups.
- ✓ Order fulfilment time optimised thanks to a global distribution network with de-localised, automated warehouses.

87% / of downtime machine orders fulfilled within 24 hours.

95% / of orders delivered in full on time.

100 / spare part staff in Italy and worldwide.

500 / orders processed every day.

# Technical data



Active 400		
Machine dimensions	mm / inch	3350 - 3500 - 1480 / 131,8 - 137,7 - 58,2
Blade inclination angle	degrees	0 - 45°
Max. cutting height with D400mm saw blade (0° - 45°)	mm / inch	125 (0°) - 85 (45°) / 4,9 (0°) - 3,3 (45°)
Sliding table stroke	mm / inch	3200 / 125,9
Max. cutting width with rip cut fence	mm / inch	1250 / 49,2
Max. cutting length with cross cut fence	mm / inch	3200 / 125,9
Main blade rotation speed	r/min	3200 - 4000 - 6000
Scoring blade rotation speed	r/min	8000
Scoring blade shaft diameter	mm / inch	20 / 0,8
Main blade shaft diameter	mm / inch	30 / 1,2
Scoring blade diameter	mm / inch	120 / 4,7
Main blade diameter	mm / inch	250 - 400 / 9,8 - 15,7

The technical specifications and drawings are non-binding. Some photos may show machines equipped with optional features. Biesse Spa reserves the right to carry out modifications without prior notice.

A weighted sound pressure level (LpA) during machining for operator workstation on vane-pump machine Lpa=79dB(A) Lwa=96dB(A) A-weighted sound-pressure level (LpA) for operator workstation and sound power level (LwA) during machining on cam-pump machine Lwa=83dB(A) Lwa=100dB(A) K measurement uncertainty dB(A) 4

The measurement was carried out in compliance with UNI EN 848-3:2007, UNI EN ISO 3746: 2009 (sound power) and UNI EN ISO 11202: 2009 (sound pressure levels at workstation) during panel machining. The noise levels shown are emission levels and do not necessarily correspond to safe operation levels. Despite the fact that there is a relationship between emission and exposure levels, this may not be used in a reliable manner to establish whether further measures need to be taken. The factors determining the exposure level for the workforce include length of exposure, work environment characteristics, other sources of dust and noise, etc. i.e. the number of other adjoining machines and processes. At any rate, the above information will enable the operator to better evaluate dangers and risks.

# Biesse Group

In

1 industrial group, 4 divisions  
and 8 production sites.

How

€ 14 million p/a in R&D and 200 patents registered.

Where

34 branches and 300 agents/selected dealers.

With

customers in 120 countries (manufacturers of furniture,  
design items and door/window frames, producers of ele-  
ments for the building, nautical and aerospace industries).

We

3,200 employees throughout the world.

**Biesse Group** is a multinational leader in the  
technology for processing wood, glass, stone, plastic  
and metal.

Founded in Pesaro in 1969, by Giancarlo Selci, the  
company has been listed on the Stock Exchange  
(STAR segment) since June 2001.

 **BIESSEGROUP**

 **BIESSE**

 **INTERMAC**

 **DIAMUT**

**MECHATRONICS**

