

**DO  
MORE  
TODAY  
WITH  
BOTTENE**



**MON  
DIAL**

Cross Cut Saws

---

Scanners

---

Automation

---

Finger Jointers

---

Planers, moulders & multiripsaw



**Bottene srl**  
Via Emilia Romagna 24  
36015 Schio • Vicenza • Italy  
tel. +39 0445 500159  
Fax +39 0445 579700  
bottene@bottene.it

[www.bottene.it](http://www.bottene.it)

**DO MORE TODAY WITH BOTTENE**

## MONDIAL

The multiripsaw MONDIAL is the ideal solution to produce not planned boards when strength and flexibility are required. Equipped with 1 fixed sawblade and 4 sawblades movable automatically, it allows to get the maximum optimization of the boards and a considerable saving of wastes. The positioning of the sawblade is controlled by Brushless motors and the software allows to store the different combinations that can be recalled quickly and precisely by the operator. MONDIAL is equipped as standard with roller feeder and soundproof cabinet and it can be completed with our automatic loading and unloading systems made especially for composition of automatic lines.

### Technical data

	MONDIAL
Max cutting width	500 mm
Feeding beltconveyor width	590 mm
Max. passage width	1.000 mm
Max. cutting height	125 mm
Min-max sawblade diameter	300-400 mm
Sawblade-holder shaft motor power	55 kw (HP75)
Min. working length	700 mm
Ajustable feeding speed	5-50 m/min
Feeding motor power	3 kw (HP4)
Working table height	810 mm
Suction hood diameter	250 mm
Suction speed	30 m/sec
Suction volume	6360 m <sup>3</sup> /h
Weight	6.300 kg

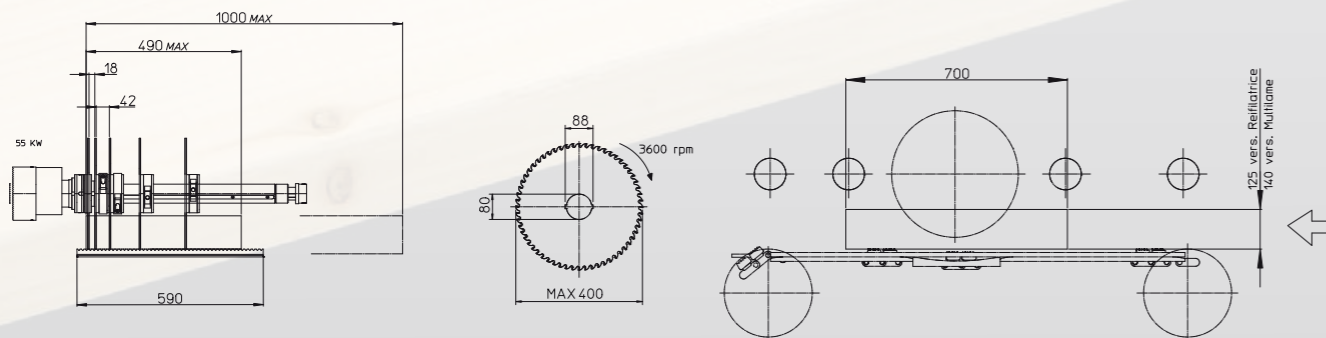

Countersupported sawblade-holder shaft

Sawblades positioning with Brushless motors