

5 X M
S E R I E S

BULLERI

BULLERI
BREVETTI

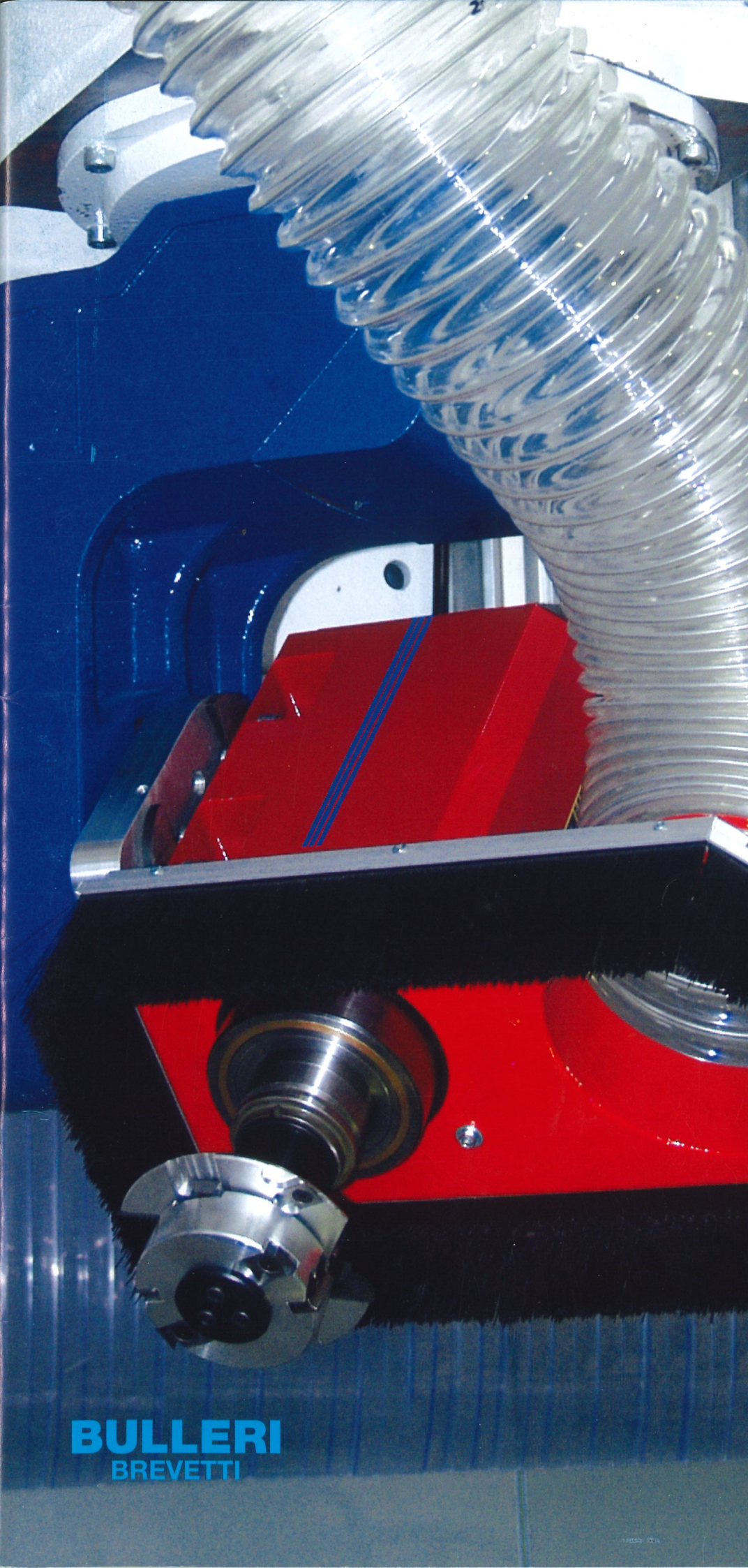



BULLERI
BREVETTI

5 X M S E R I E S

 La serie 5XM della Bulleri Brevetti assomma tutta la filosofia produttiva e tecnologica dell'Azienda. La macchina nelle versioni FPM 5XM e Twister 5XM sono offerte le prime con piano di lavoro fisso e portale chiuso mobile con teste a 5 assi in continuo con o senza barre portaventose e sono nate principalmente sia per lavorazioni dove il 5 asse è richiesto ma principalmente nel settore degli infissi, finestre, archi e porte dove con una sola testa è possibile eseguire tutte le lavorazioni mentre le seconde sono più usate nei settori della modellistica, cantieri navali, modelli per auto, caravans e tutto ciò che concerne la modellistica industriale.

 Bulleri Brevetti's 5XM series incorporates all the Company's production and technological philosophy. The machine is available in the FPM 5XM and Twister 5XM models. The former features fixed worktable and mobile closed portal with 5-axis continuous heads with or without suction-cup bars and has been designed for wherever 5-axis machining operations are required, but mainly for the frame, window, arch and door industry, where all operations can be performed with just one head. The latter, on the other hand, is mainly used in the modelmaking, shipbuilding, car model and caravan industry and in all industrial modelmaking sectors.

 La série 5XM de Bulleri Brevetti traduit parfaitement l'approche choisie par l'entreprise en terme de production et de technologie. Les machines de la version FPM 5XM sont proposées avec une table de travail fixe et un portique fermé, mobile à broches de 5 axes en continu, avec ou sans barres porte-ventouses; elles ont été essentiellement conçues pour les travaux exigeant un 5e axe, notamment dans le secteur des fenêtres, arcs et portes où une seule broche suffit à l'exécution de tous les travaux. Quant aux machines de la version Twister 5XM, elles conviennent mieux aux secteurs du modélisme, chantiers navals, maquettes de voiture, caravanes et à tout ce qui concerne le modélisme industriel.



 In der Serie 5XM der Firma Bulleri Brevetti sind die vom Unternehmen angewandte Produktionsphilosophie und Technologie vereint. Die Maschinen werden wie folgt angeboten: Die Version FPM 5XM mit stationärem Arbeitstisch und beweglichem, geschlossenem Portal mit Köpfen mit 5 kontinuierlichen Achsen, mit oder ohne Saugnapfhalterschienen; sie ist vornehmlich für Bearbeitungen, die eines 5-Achsen-Kopfes bedürfen, sowie für Einfassungen, Fenster, Bögen und Türen, wo mit nur einem Kopf alle Arbeitsgänge gemacht werden können, konzipiert. Die Version Twister 5XM kommt mehr auf dem Gebiet des Modellbaus, der Schiffswerften, Modelle für Autos, Caravans und für alles was den industriellen Modellbau anbetrifft zum Einsatz.

 La serie 5XM de Bulleri Brevetti aúna toda la filosofía productiva y tecnológica de la empresa. Las máquinas en la versión FPM 5XM se ofrecen con mesa de trabajo fijo y pórtico cerrado con cabezales de 5 ejes en continuo, con o sin barras portaventosas, y están pensadas tanto trabajos en los que se requiere el 5 eje como, principalmente, para el sector de los bastidores, ventanas, arcos y puertas, en el que con una única cabeza se pueden realizar todos los trabajos. Las máquinas en la versión Twister 5XM se utilizan preferentemente en los sectores de la modelística, astilleros navales, modelos para automóviles, autocaravanas y todo aquello que concierne a la modelística industrial.

BULLERI BREVETTI srl

Sede legale:

Via Lombardia, 23 - 41012 Carpi (MO) - Tel. 059/644825 - Fax 059/646114

Stabilimento e Uffici Commerciali :

Viale Etruria, 15 - 56021 Cascina (PI) Italy - Tel. 050/71641 - Fax 050/700618

e-mail: bulleri.info@bulleri.com

FPM 5XM

Macchina equipaggiata con piano di lavoro in LPM e ventose ad innesto rapido.

Machine featuring LPM worktable and quick-coupling suction cups.

Machine équipée d'une table de travail en LPM et ventouses à montage rapide.

Die Maschine ist mit Arbeitstisch aus LPM und Schnellkupplungssaugnapfen ausgestattet.

Máquina equipada con mesa de trabajo de LPM y ventosas de acoplamiento rápido.



5 X M SERIES

Magazzino utensili girevole a 16 posizioni attacco HSK F63.

16-position revolving type tool magazine with HSK F63 coupling.

Magasin des outils pivotant sur 16 positions, fixation HSK F63.

Drehbares Werkzeugmagazin mit 16 Positionen HSK F63 Halterung.

Almacén de herramientas giratorio con 16 posiciones, fijación HSK F63.

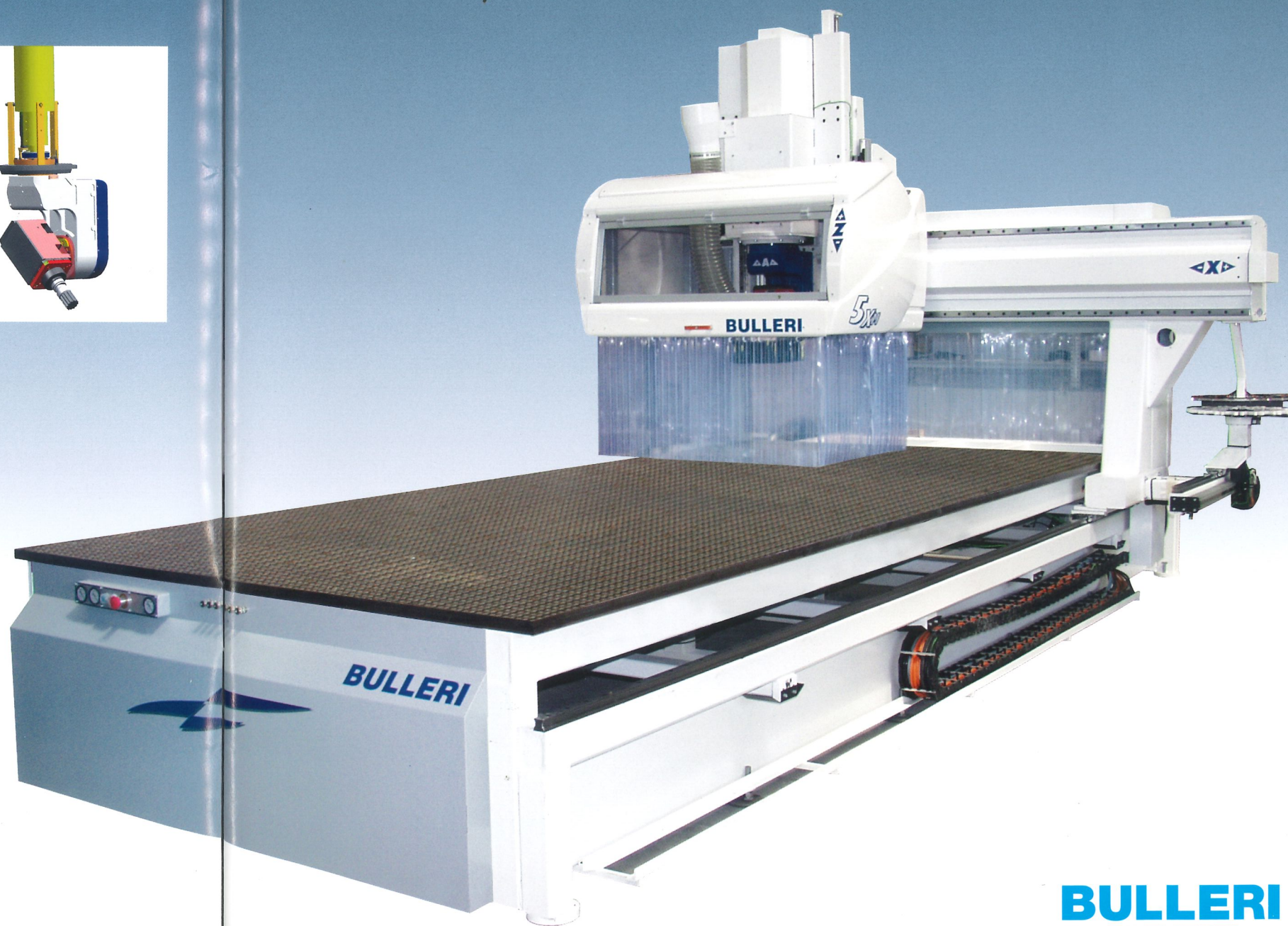
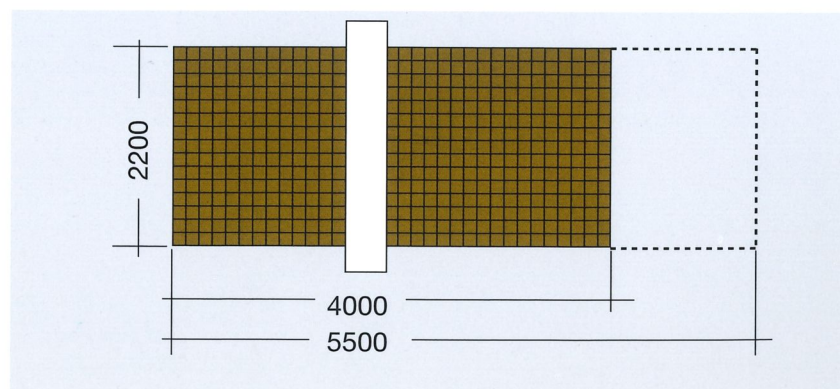
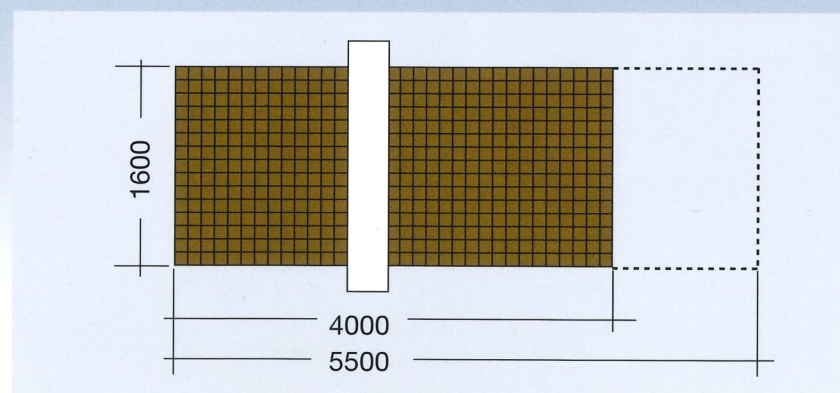
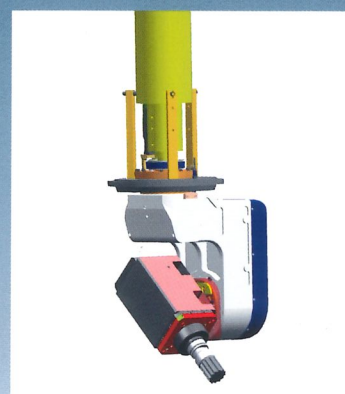
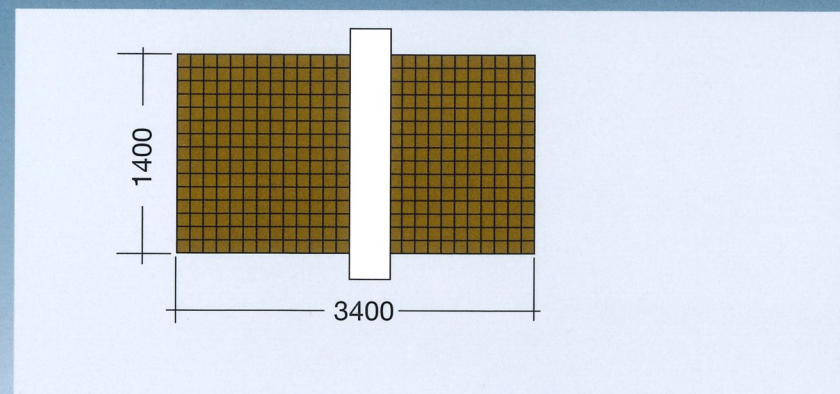
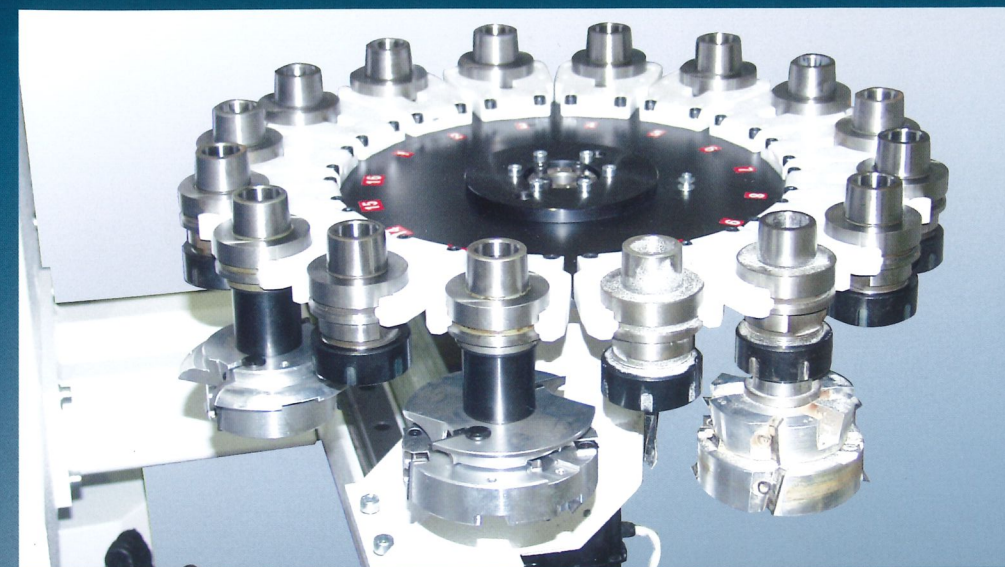

FPM 40/16 5XM

BULLERI
BREVETTI



La struttura a ponte mobile crea un anello chiuso. Le lamiere tubolari di grande spessore eliminano qualsiasi tipo di vibrazione. Le guide lineari e i pattini usati sono i migliori del mercato.

The mobile bridge structure creates a closed ring. The extra-thick tubular metal sections eliminate any kind of vibration. The linear guides and sliding blocks used are the best available on the market.

L'ossatura à pont mobile, fermé également dans le bas, forme une boucle fermée. Les guides linéaires et les patins utilisés sont les meilleurs produits existant dans le commerce; les éléments tubulaires utilisés sont très épais et ils assurent l'absence de toute vibration.

Die Struktur mit beweglicher, auch von unten geschlossener Bühne bildet einen geschlossenen Ring. Die linearen Führungen und die verwendeten Gleitbacken sind die besten des Markts; die dicken Rohrbleche verhindern jede Art von Schwingung.

La estructura de puente móvil crea una anillo cerrado. Las guías lineales y los patines utilizados son los mejores del mercado. Las chapas tubulares de gran espesor eliminan cualquier tipo de vibración.

ACE

5 X M
SERIES

AA

2 SUPERLEX PU-1



BULLERI
BREVETTI

FPM 55/14V 5XM



Barra in alluminio mobile completa di ventose e pistoni di riferimento pezzi in lavoro.

Mobile aluminium bar complete with suction cups and workpiece reference pistons.

Barre en aluminium mobile avec ventouses et pistons de repère des pièces au travail.

Bewegliche Aluminiumschiene mit Saugnäpfen und Werkstück-Bezugskolben.

Barra de aluminio móvil provista de ventosas y pistones de referencia para las piezas de trabajo.

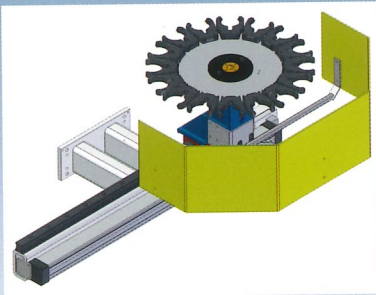
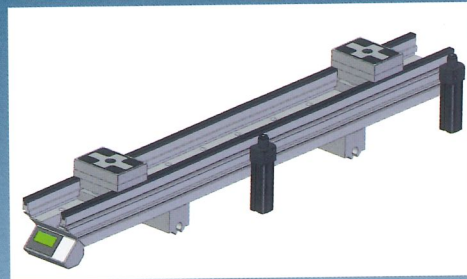

Magazzino utensili girevole a 16 posizioni montato su colonna mobile attacco HSK F63 completo di cono.

16-position revolving tool magazine mounted on HSK F63 coupling moving column complete with cone.

Magasin outils pivotant sur 16 positions monté sur colonne mobile, fixation HSK F63 avec cône.

Drehbares Werkzeugmagazin mit 16 Positionen, angebracht an einer beweglichen Säule, HSK F63 Halterung komplett mit Kegel.

Almacén de herramientas giratorio de 16 posiciones montado en columna móvil, fijación HSK F63 provista de cono.

Particolare macchina FPM 5514 5XM – cabina di protezione in ABS e barre portaventose.

Detail of FPM 5514 5XM machine– ABS protection enclosure and suction-cup bars.

Détail de la machine FPM 5514 5XM – cabine de protection en ABS et barres porte-ventouses.

Detail FPM 5514 5XM – Schutzkabine aus ABS und Saugnäpfbalterschienen.

Detalle de la máquina FPM 5514 5XM – cabina de protección de ABS y barras porta-ventosas.

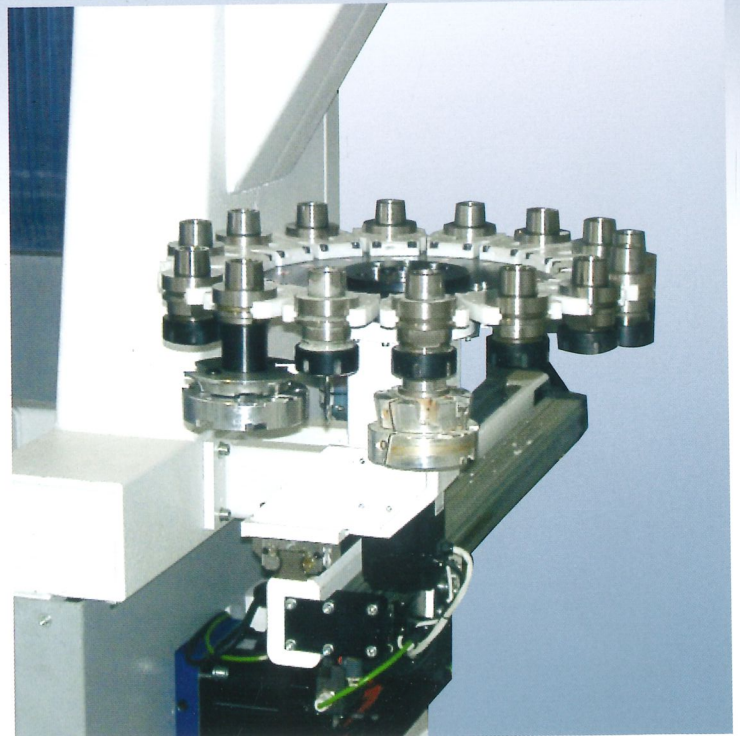

5 X M
S E R I E S



BULLERI
BREVETTI

FPM 5XM

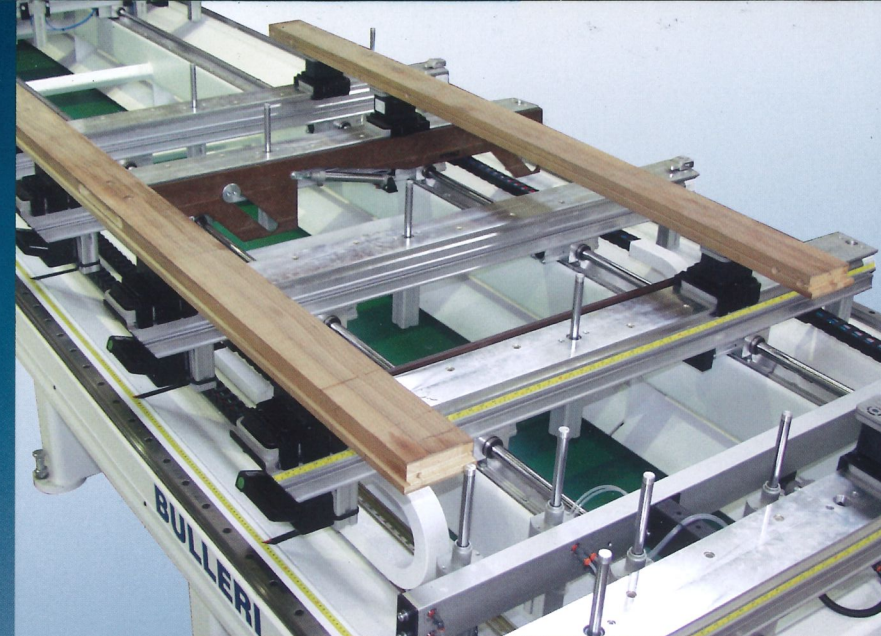
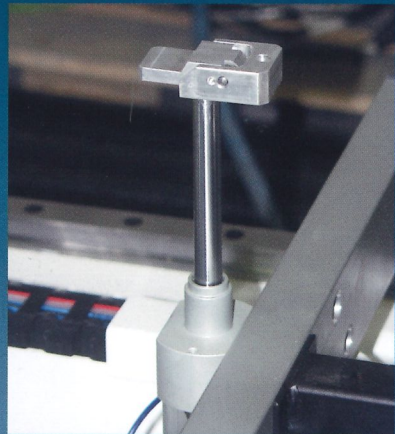

5 X M SERIES

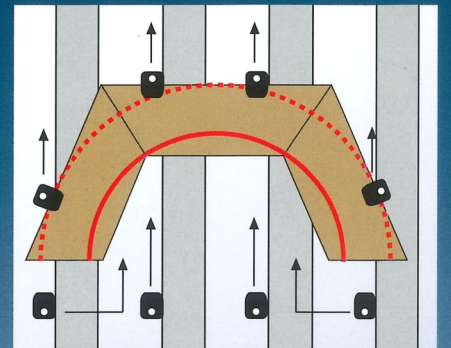

Arco di finestra bloccato su piano con barre e pressori.

Window arch on table by means of bars and clamps.

Fixation de fenêtre bloquée sur table avec barres et presseurs.

Mit Schienen und Niederhaltern am Tisch befestigte Fensterhalterung.

Arco de ventana bloqueada en la mesa con barras y prensos.

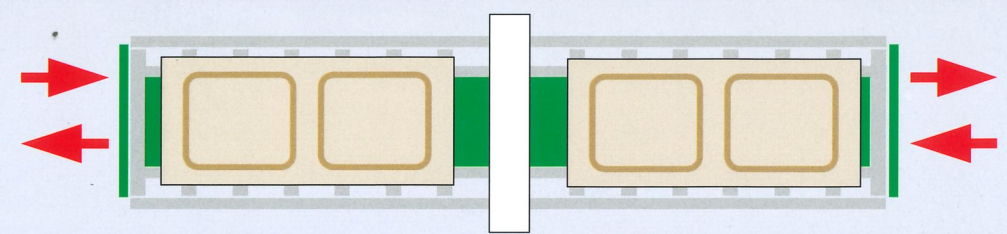

Schema di carico e scarico di porte tamburate su piano di lavoro.

Loading and unloading diagram relating to double-panelled doors on worktable.

Schéma de chargement et déchargement de portes en aggloméré sur la table de travail.

Schema zum Laden/Abladen furnierter Türen auf/vom Arbeitstisch.

Esquema de carga y descarga de puertas con estructura alveolar en la mesa de trabajo.

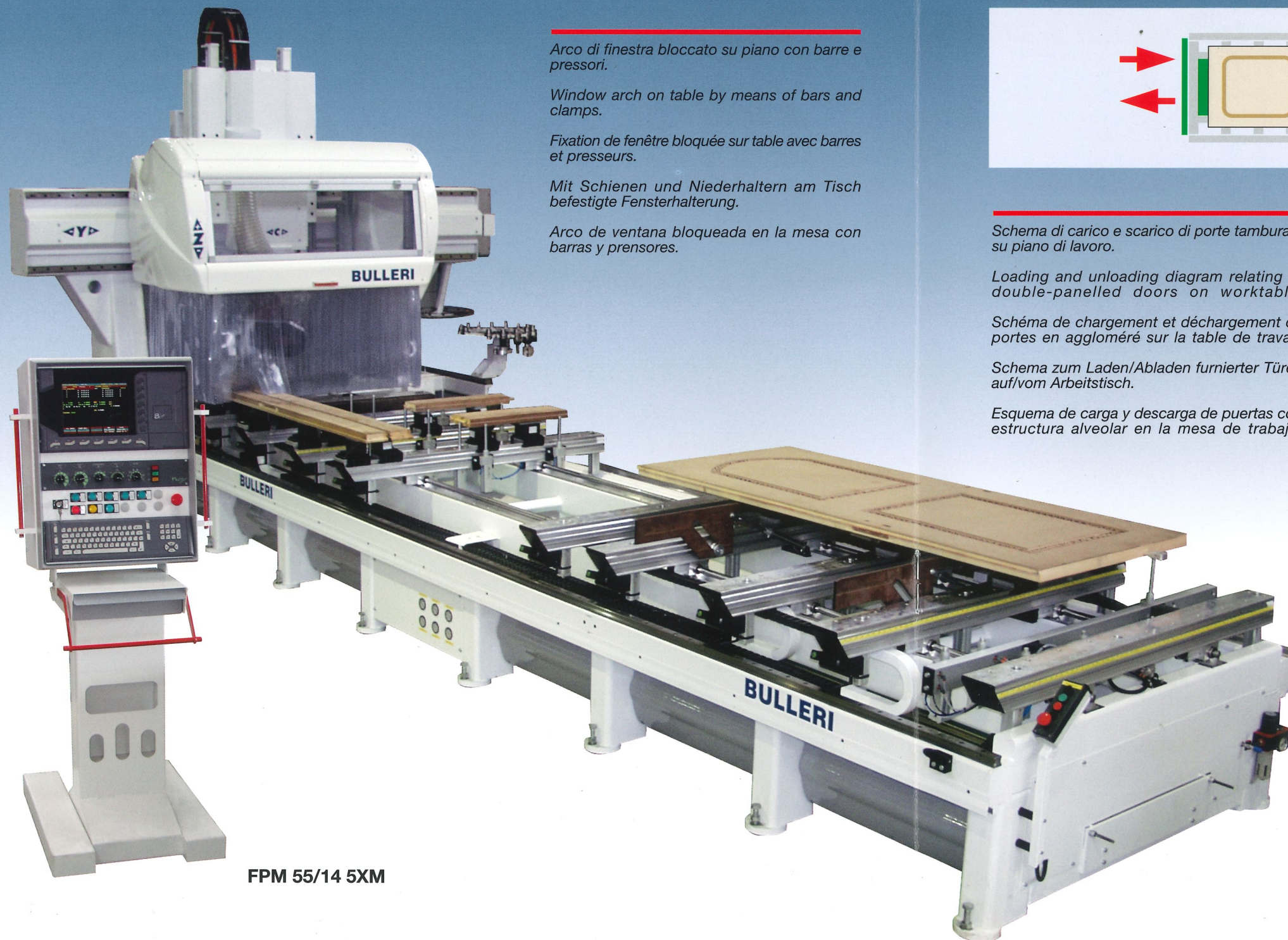

FPM 55/14 5XM

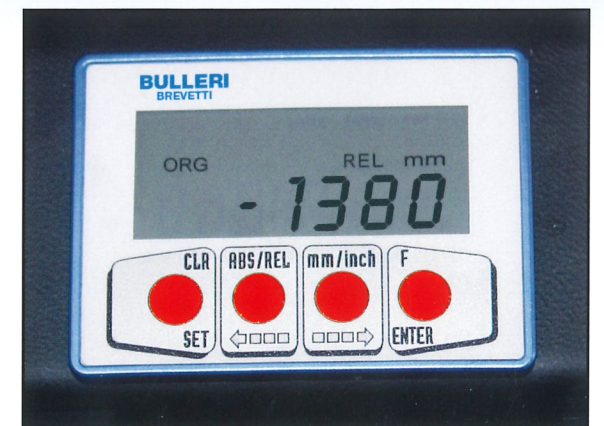

BULLERI
BREVETTI

TWISTER

Twister 5XM: elemento asse Z completo di motore e cambio utensile.

Twister 5XM: axis Z complete with motor and tool change.

Twister 5XM: élément axe Z avec moteur et changement d'outil.

Twister 5XM: Z-Achse komplett mit Motor und Werkzeugmagazin.

Twister 5XM: elemento eje Z con motor y cambio de herramientas.



**T
W
I
S
T
E
R**

5 X M
S E R I E S

5
X M

BULLERI
BREVETTI

TWISTER

Twister 5XM con piano di lavoro in LPM quadrettato.

Twister 5XM with worktable in chequered LPM.

Twister 5XM avec table de travail en LPM quadrillé.

Twister 5XM mit Arbeitstisch aus gekästeltem LPM.

Twister 5XM con mesa de trabajo de LPM cuadrículado.

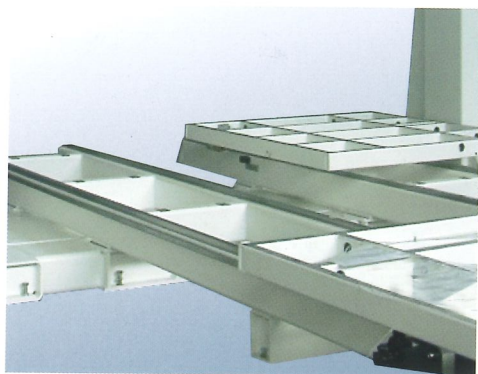

Struttura di lavoro composta da telai elettrosaldati a forte spessore.

Work structure consisting of extra-thick electrically-welded frames.

Structure de travail formée de châssis mécanosoudés de forte épaisseur.

Arbeitsstruktur aus e-geschweißten, dicken Rahmen.

Estructura de trabajo compuesta por bastidores electrosoldados de gran espesor.

5 X M
S E R I E S

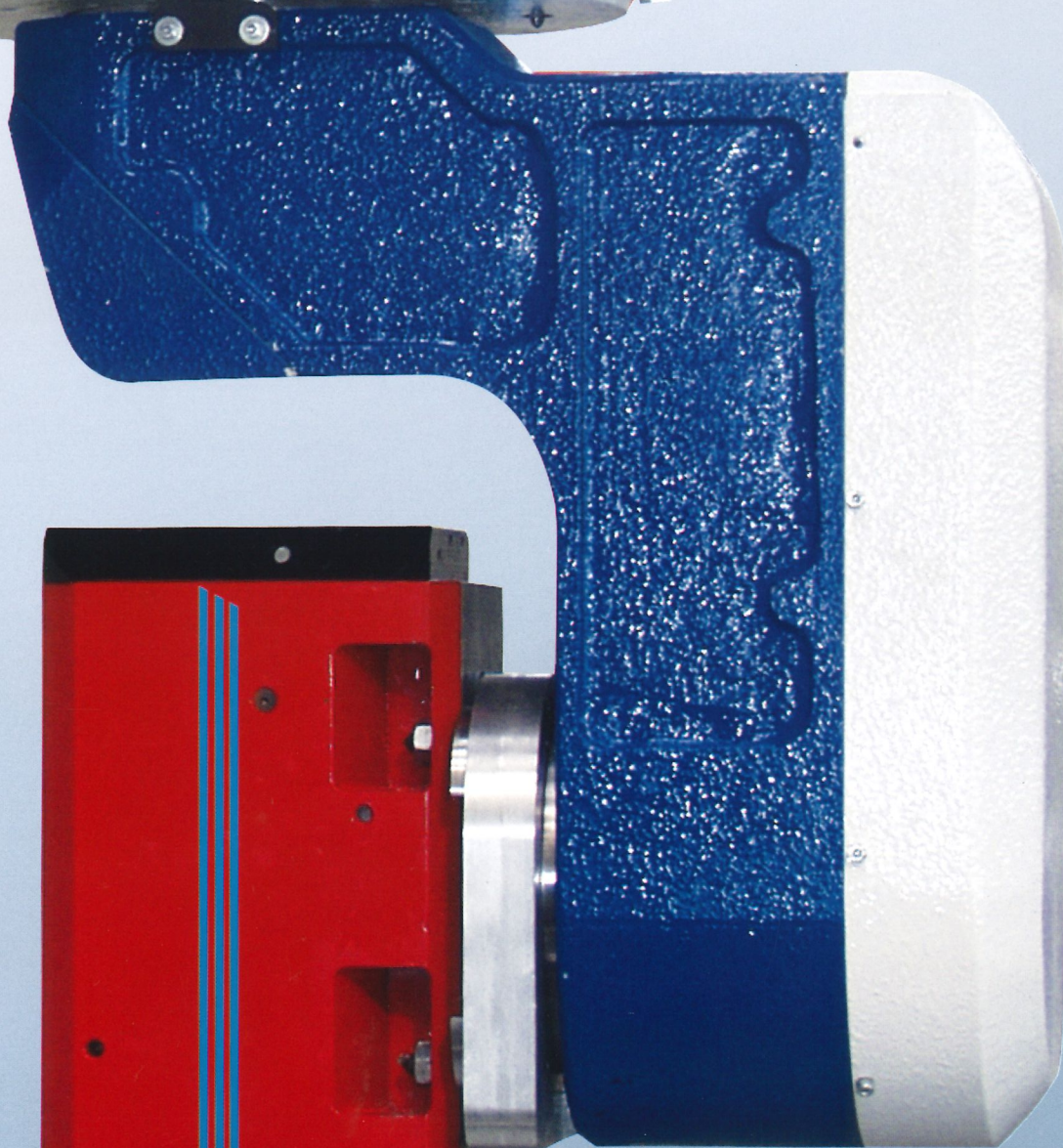

BULLERI
BREVETTI

TWISTER

Twister 5XM con due piani di lavoro mobili e asse Z di mm.1700.

Twister 5XM with two moving worktables and 1700 mm Z axis.

Twister 5XM avec deux tables de travail mobiles et un axe Z de 1700 mm.

Twister 5XM mit zwei beweglichen Arbeitstischen und Z-Achse 1700 mm.

Twister 5XM con dos mesas de trabajo móviles y eje Z de 1700 mm.

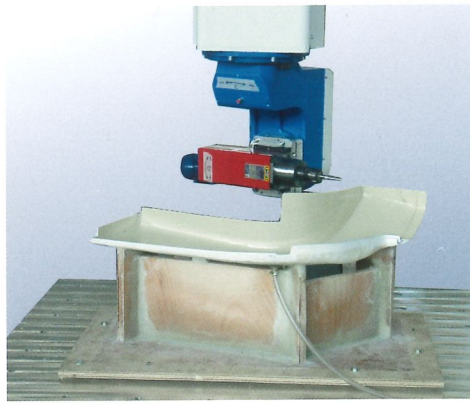
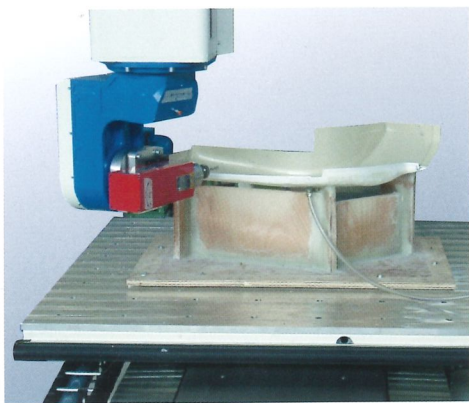
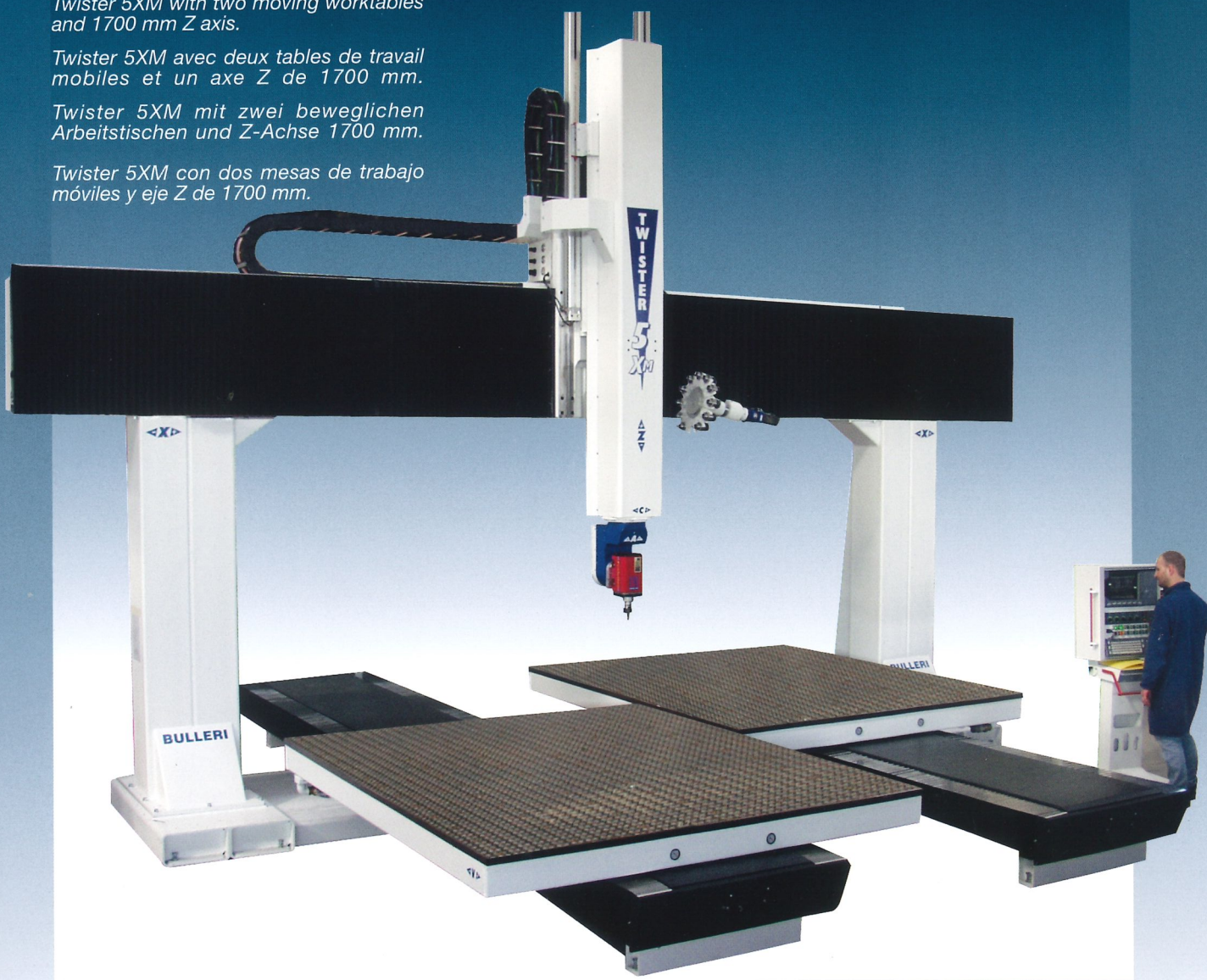

Lavorazioni in orizzontale di elementi in plastica.

Horizontal machining of plastic pieces.

Travaux à l'horizontale d'éléments en plastique.

Waagrechte Bearbeitung von Kunststoffwerkstücken.

Trabajos en horizontal de elementos de plástico.

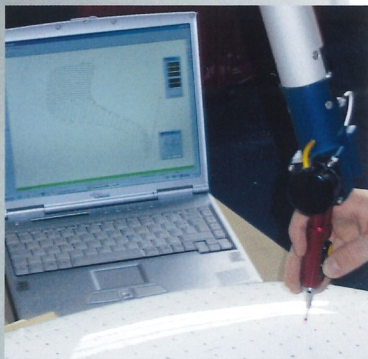

5 X M S E R I E S

Sistema di autoapprendimento elettronico con braccio antropomorfo e software dedicato 3D.

Electronic self-learning system with anthropomorphous arm and dedicated 3D software.

Système d'auto-apprentissage électronique avec bras anthropomorphe et logiciel dédié 3 D.

Elektronisches Selbstlernsystem mit anthropomorphem Arm und spezieller 3D-Software.

Sistema de autoaprendizaje electrónico con brazo antropomorfo y software dedicado 3D.



BULLERI
BREVETTI

TWISTER

Particolari di lavorazioni di precisione.

Details of precision machining.

Détails de travaux de précision.

Details von Präzisionsbearbeitungen.

Detalles de trabajos de precisión.

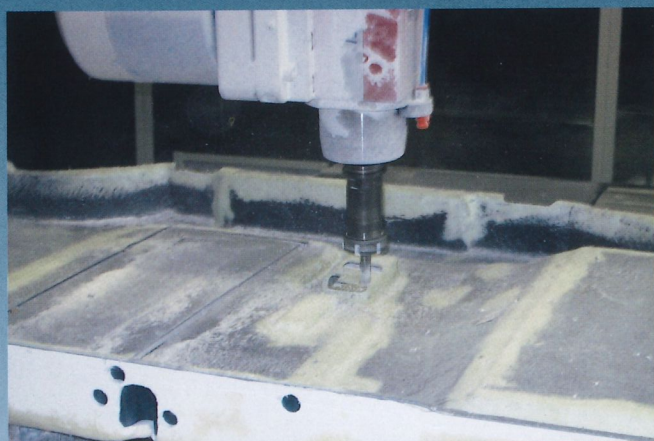

Cabina di protezione integrale con porte sul fronte per far funzionare e caricare/scaricare i piani di lavoro.

Complete protection enclosure with doors on front for operating and loading/unloading the worktables.

Cabine de protection intégrale avec portes sur le front pour faire fonctionner et charger/décharger les tables de travail.

Integrale Schutzkabine mit vorderen Türen zur Bedienung und Arbeitstischbeladung/-entladung.

Cabina de protección con puertas en la parte frontal para hacer funcionar y cargar/descargar las mesas de trabajo.

5 X M SERIES

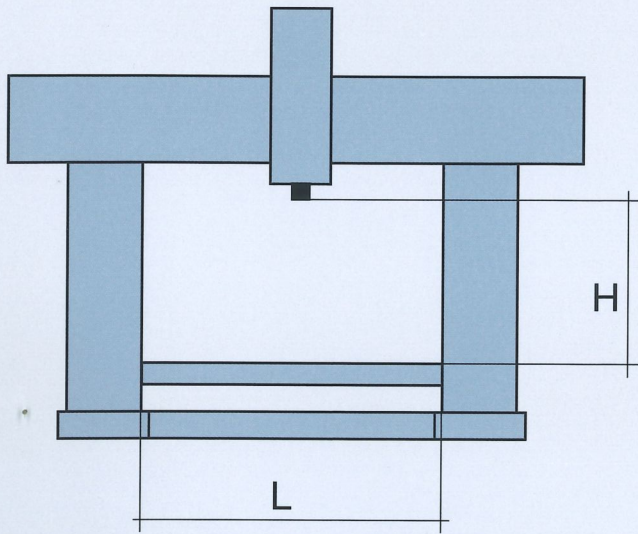

Misure
Measurements
Dimensions
Maße
Medidas

H	L
1050	3500
1700	4200
1880	5500
2110	6000

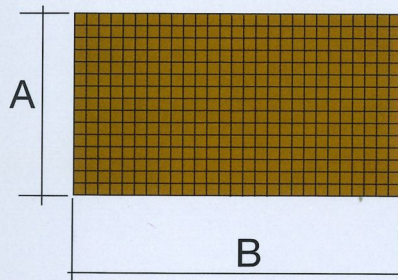

A	B
1600	1600
	2600
	3200

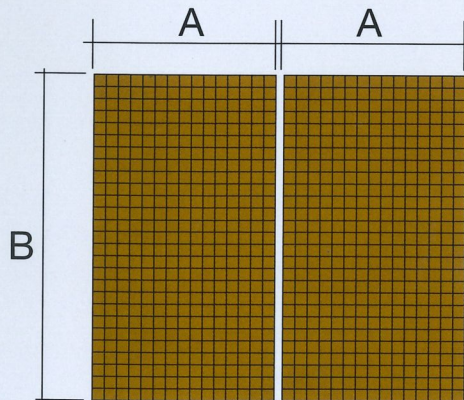

A	B
1600	1600
2250	2600
2460	2850
2850	

Motore mandrino
Spindle motor
Moteur mandrin
Spindelmotor
Motor mandril

6 ÷ 12 kW

0 ÷ 30.000 RPM

BULLERI
BREVETTI

BULLERI BREVETTI

BULLERI BREVETTI srl

Sede legale:
Via Lombardia, 23
41012 Carpi (MO)
Tel. 059/644825 - Fax 059/646114

Stabilimento e Uffici Commerciali :
Viale Etruria, 15
56021 Cascina (PI) - Italy
Tel. 050/71641 - Fax 050/700618
e-mail: bulleri.info@bulleri.com

BULLERI SERVICE

Tel. 050.71641
e-mail: service.info@bulleri.com

