

 **BUSELLATO**

cnc working centers

JET OPTIMA

I centri di lavoro JET OPTIMA sono espressamente concepiti per la produzione di componenti di mobili e porte da interni. E' un centro di lavoro compatto che mantiene prestazioni allineate ai modelli superiori. Il centro di lavoro JET OPTIMA è un ottimo investimento per tutti gli artigiani.

The JET OPTIMA working centers have been designed for the production of furniture parts and interior doors. It is a compact working center which maintains the high performance of the larger models. The JET OPTIMA working center is a very good investment for all craftsmen.

Los centros de trabajos JET OPTIMA están expresamente concebidos para la producción de componentes de muebles y puertas de interiores. Es un centro de trabajo compacto que mantiene prestaciones alineadas a los modelos superiores. El centro de trabajo JET OPTIMA es una óptima inversión para todos los artesanos.

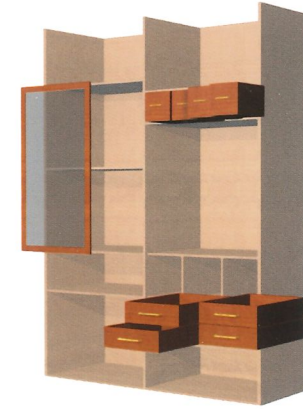
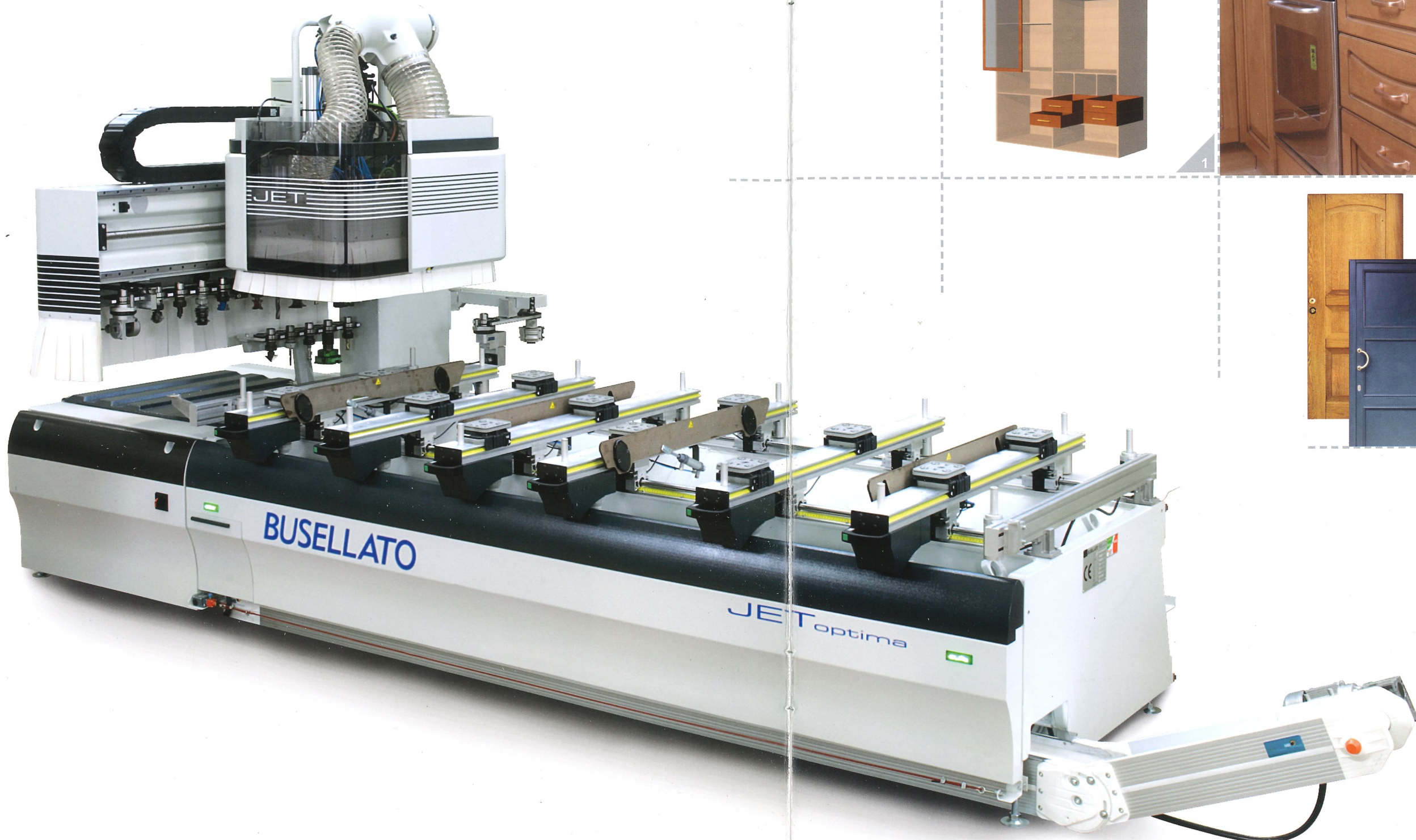

BUSELLATO is certified
ISO 9001: 2000

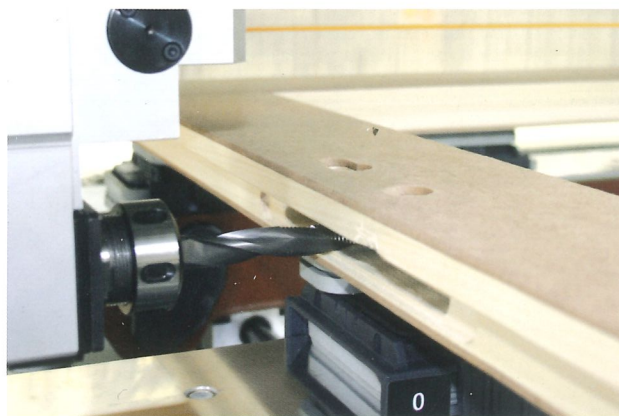
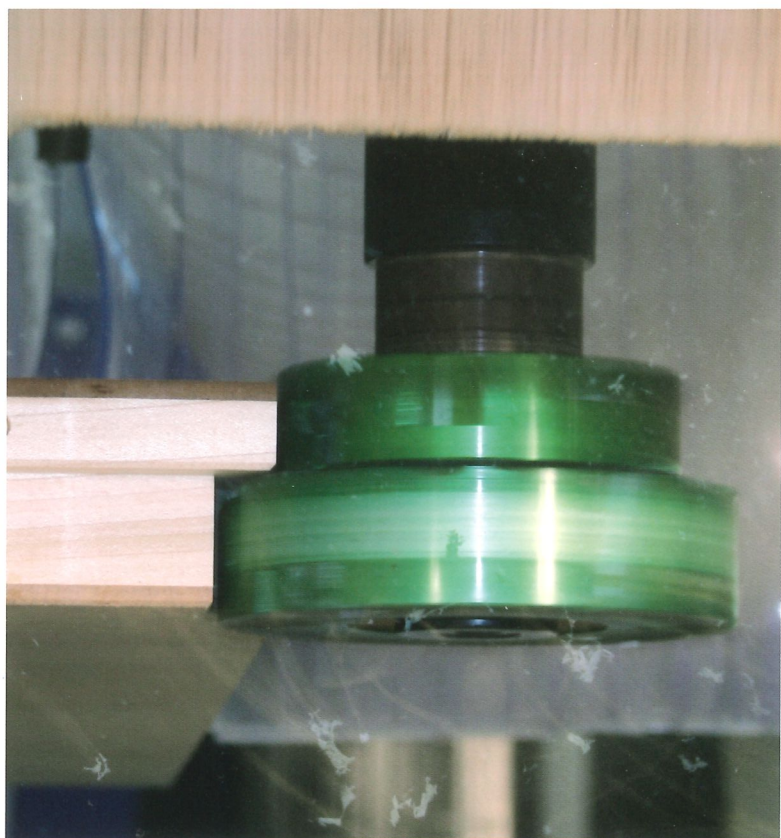

lavorazioni di porte da interni
machining interior doors
trabajos de puertas de interiores

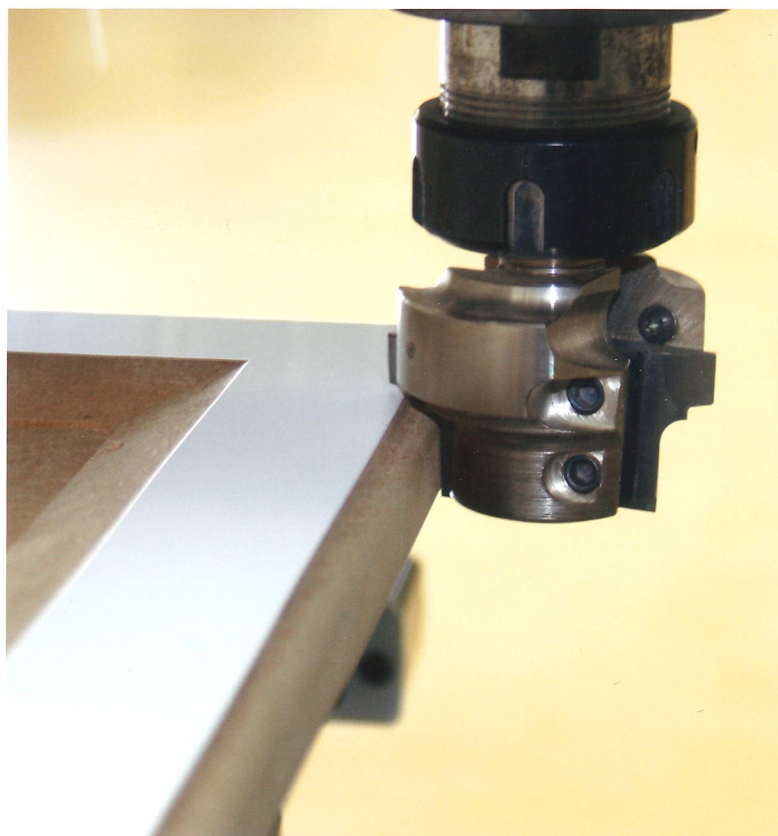
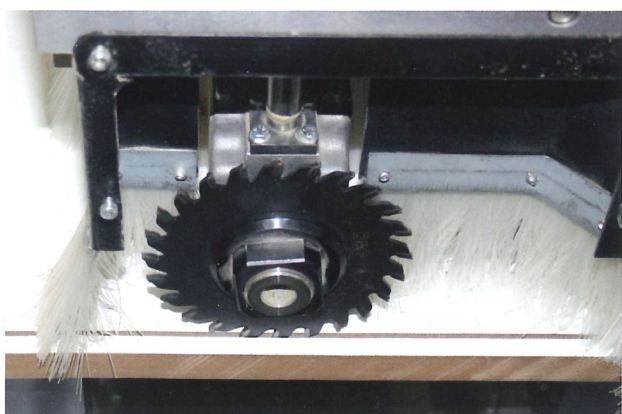
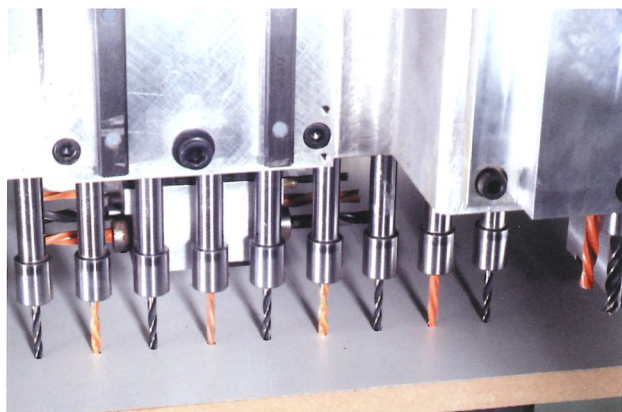

lavorazioni di componenti del mobile
machining furniture parts
trabajos de componentes del mueble

piani di lavoro

I centri di lavoro JET OPTIMA sono equipaggiati con piani TL (tubeless) a un circuito di vuoto. Le ventose sono dotate di un sistema a pinza che le trattiene al piano nelle fasi di carico e scarico del pannello. Il banco di lavoro così costituito diventa un sistema semplice ed efficace.

The JET OPTIMA working centers are equipped with TL (tubeless) panel supports with a single vacuum circuit. The vacuum cups have a clasp system which holds it on the panel support during panel loading and unloading. Set up in this way, the work bed is a simple but efficient system.

panel supports

mesas de trabajo

Los centros de trabajo JET OPTIMA están equipados con mesas TL (tubeless) a un circuito de vacío. Las ventosas están dotadas de un sistema a pinza que las sujeta a las mesas en fase de carga y descarga del tablero. De esta manera el banco de trabajo resulta un sistema simple y eficaz.



sistema di posizionamento con indicatore laser
positioning system with laser indicator
sistema de posicionamiento con indicador laser



unità di lavoro



	Mandri verticali asse X X axis vertical spindles Mandriles verticales eje X	Mandri verticali asse Y Y axis vertical spindles Mandriles verticales eje Y	Mandri orizzontali asse X X axis horizontal spindles Mandriles horizontales eje X	Mandri orizzontali asse Y Y axis horizontal spindles Mandriles horizontales eje Y	Lama integrata Integrated saw Sierra integrada	Potenza motore Motor power Potencia motor
TFM18	7	5	2+2	1+1	Ø 120 mm	1,7 kW

campi di lavoro (mm) - working areas (mm) - campos de trabajo (mm)

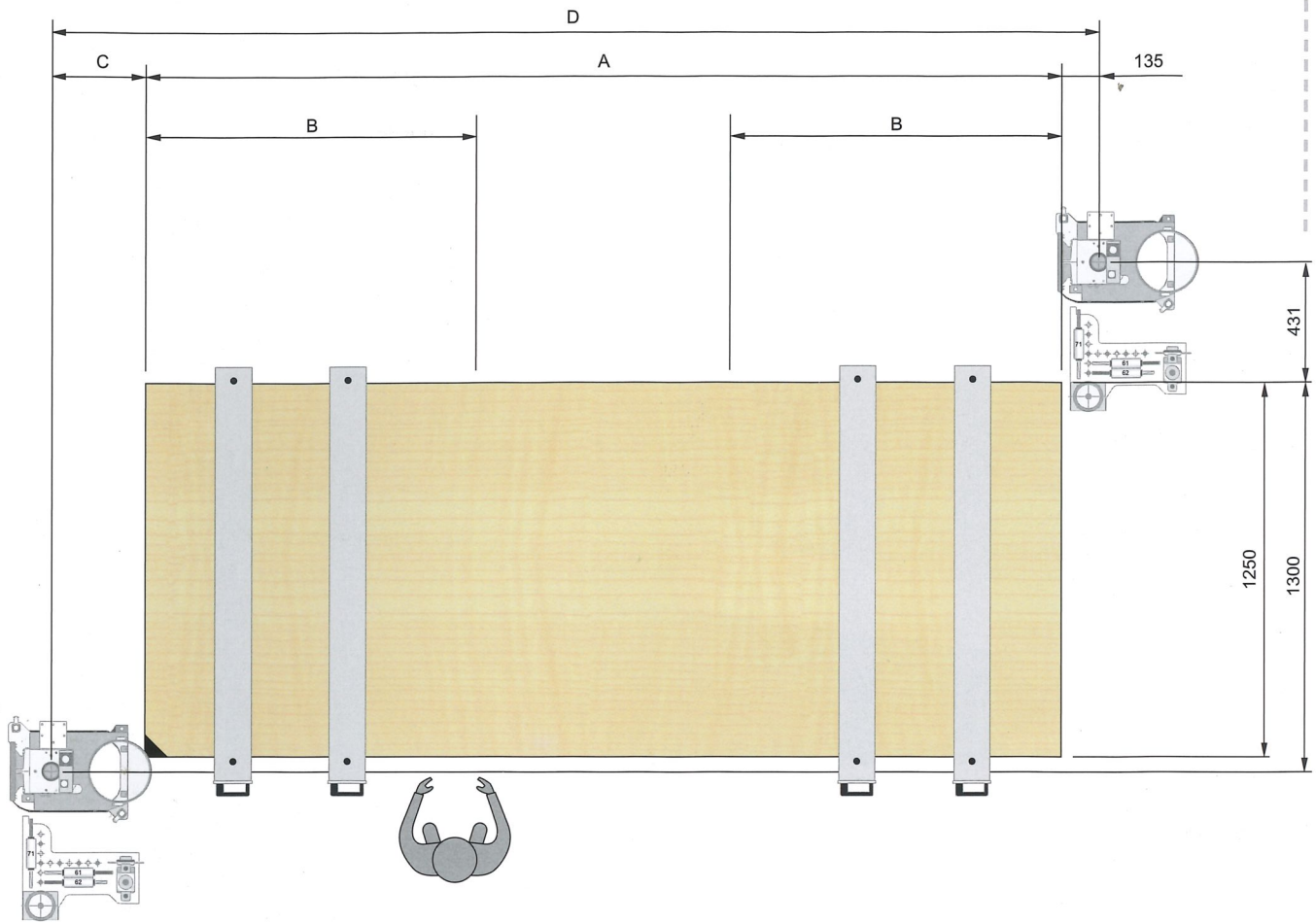

		A	B	C	D
OPTIMA C21	mm	3050	1100	506	3691

configurazioni
 configurations
 configuraciones

passaggio pezzo
 work clearance
 pasaje pieza

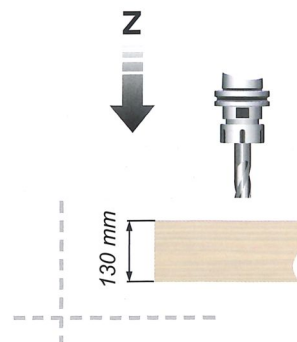
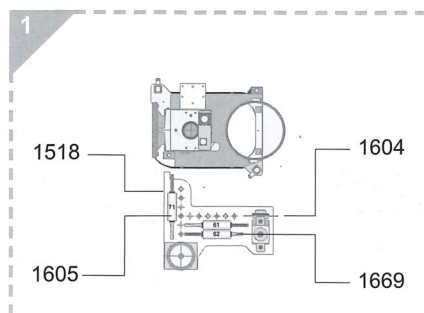

La macchina dispone di un magazzino a 8 postazioni e di una postazione posteriore adatta alla testina per lavorazioni orizzontali.

The machine is equipped with a 8-position tool changer and a rear tool position suitable for the horizontal machinings aggregate.

La maquina dispone de un almacén a 8 posiciones y de una posición posterior destinada a la cabeza para trabajos horizontales.

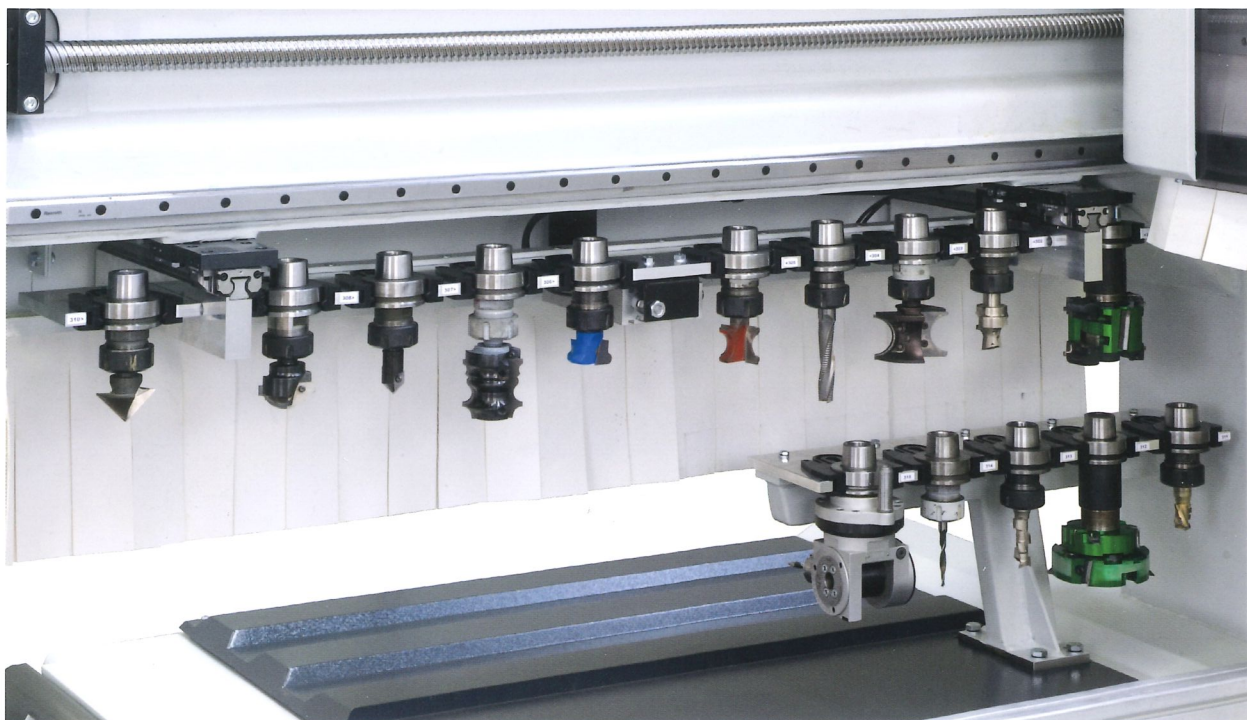

indicatori luminosi per regolare l'accesso all'area di carico/scarico
luminous indicators to regulate access to the loading/unloading area
indicadores luminosos para regular el acceso al área de carga y descarga

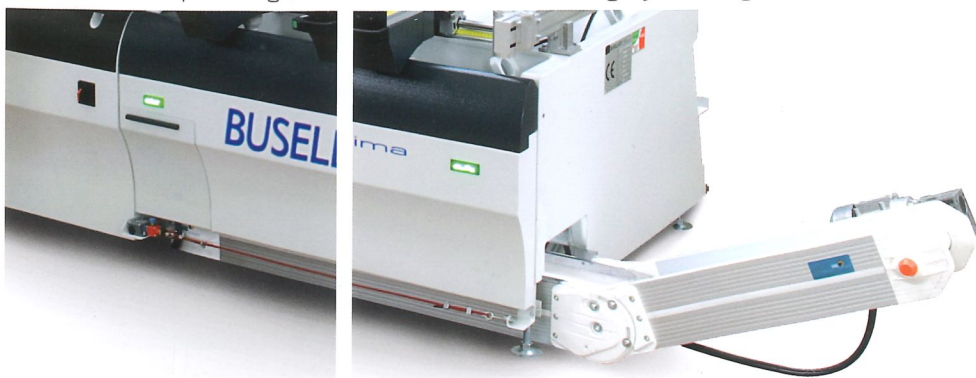

convogliatore di aspirazione parzializzato
partialized dust extraction collector
conductor de aspiración parcializado



consolle mobile per PC
mobile PC console
consola móvil para PC

Busellato rende disponibile standard su tutti i suoi centri di lavoro la teleassistenza con collegamento Internet.

Busellato offers teleservice via an internet based remote connection as standard on all its working centers.

Busellato rinde disponibile en manera estandard sobre todos los centros de trabajo, la teleasistencia con conexión a internet.

**TEAM
WORK
MOBK**

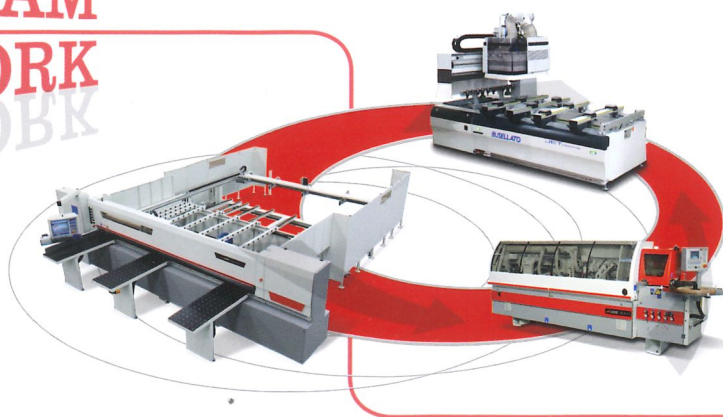

GENESIS EVOLUTION

Installato su sistema operativo Microsoft®, gestisce il controllo real-time della macchina e offre un'interfaccia utente a finestre tipica dei sistemi operativi Windows.

Installed on a Microsoft® operating system, it manages the real-time control of the machine and offers a screen based user interface typical of the Windows operating systems.

Instalado sobre sistema operativo Microsoft®, gestiona el control real-time de la maquina y ofrece un interfaz operador a ventanas típica de los sistemas operativos Windows.

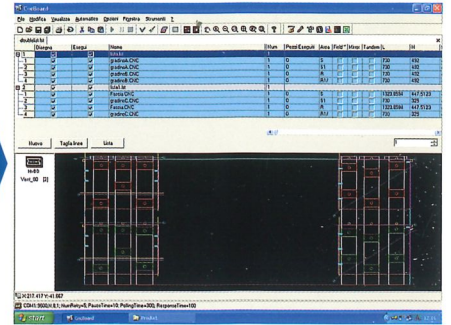
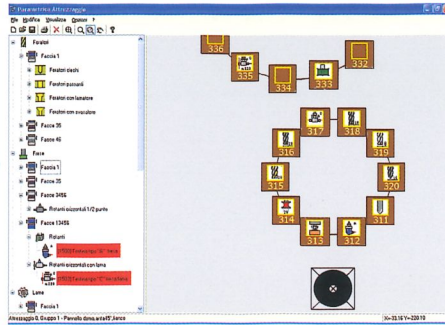
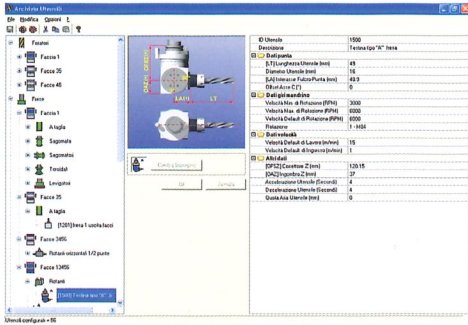

L'editor 3D è stato concepito e realizzato per fornire all'utilizzatore uno strumento potente ed immediato.

- Visualizzazione tridimensionale delle lavorazioni programmate.
- Visualizzazione delle facce fittizie nel modello tridimensionale.
- Programmazione parametrica dei programmi e sub-routines.
- Compatibilità con file di precedenti versioni di Genesis.
- Importazione e conversione file da CAD in formato DXF.
- Toolbar delle lavorazioni e "Macro" personalizzabili.
- Modulo per caratteri e svuotature.
- Modulo di simulazione.
- Importatore di file formato XLS (EXCEL®).

The 3D editor has been designed to give the user a powerful and immediate instrument.

- 3-D display of the programmed machinings.
- Display of the virtual faces in the 3-D model.
- Parametric programming of programs and sub-routines.
- Compatible with files from previous Genesis versions.
- Importation and conversion of CAD files in DXF format.
- Machining toolbar and "Macro" that can be personalized by the user.
- Character and pocket cycle modules.
- Simulation module.
- Importation of XLS (EXCEL®) format files.

El editor 3D fue concebido y realizado para dar al operador un instrumento potente e inmediato.

- Visualización tridimensional de los trabajos programados.
- Visualización de las caras ficticias en el modelo tridimensional.
- Programación paramétrica de los programas y sub-routines.
- Compatible con file de precedentes versiones de Genesis.
- Importación y conversión file de CAD en file DXF.
- Toolbar de los trabajos y "Macro" personalizables.
- Módulo para caracteres y vaciados.
- Módulo de simulación.
- Importador de file tipo XLS (EXCEL®).

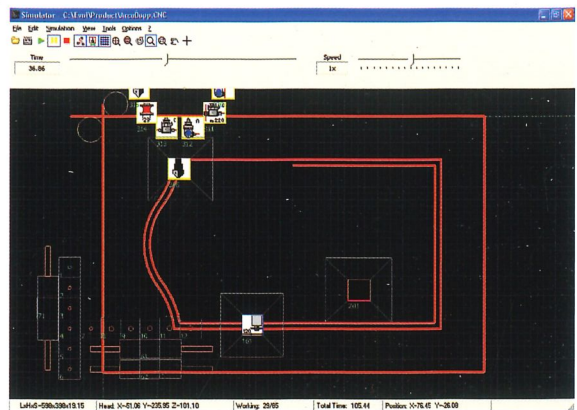
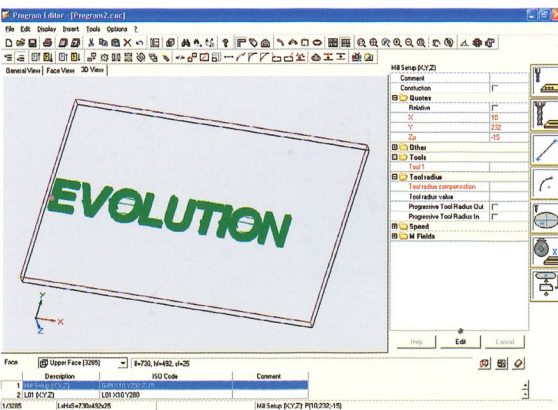
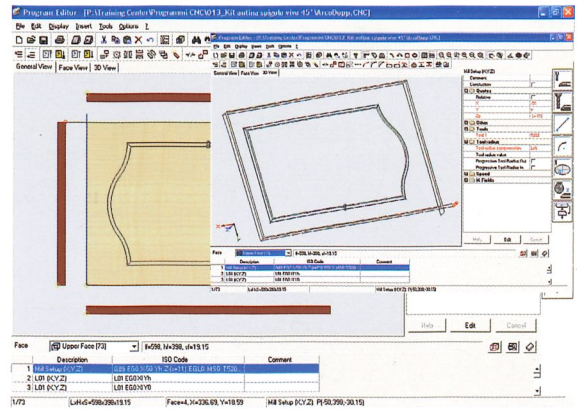
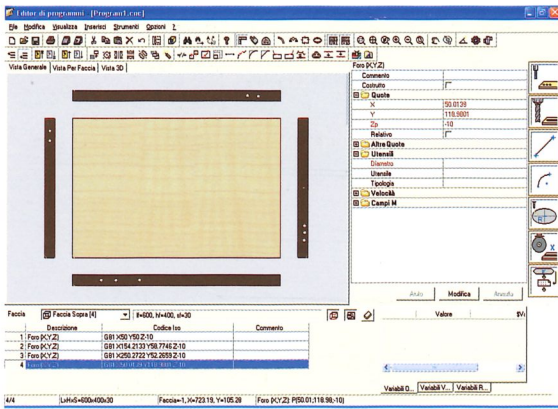

soluzioni software integrate

integrated software solutions soluciones software integradas

Soluzione software per la progettazione e la realizzazione di cabinet per l'arredamento domestico e d'ufficio con generazione automatica di programmi e liste di lavoro.

Software solution for designing and realizing cabinets for home and office furniture with automatic generation of programs and work lists.

Solución software para la proyectación y realización de Cabinet para el amueblamiento domestico y de oficina con la creación automática de programas y lista de trabajo.

JET CABINET

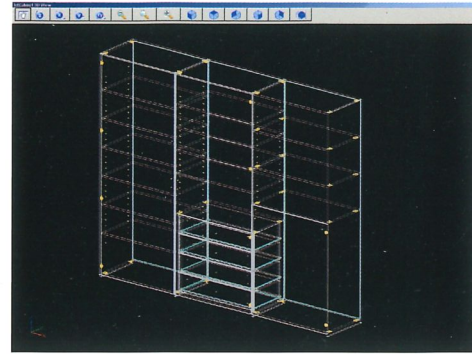
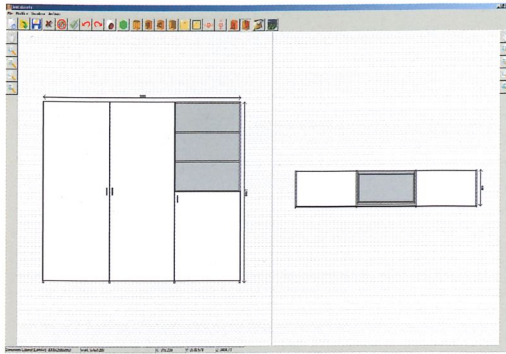

divisori verticali e ripiani
partitions and shelves
divisores verticales y ménsulas

ante, cassetti e schienali
doors, drawers and backs
puertas, cajoneras y fondos

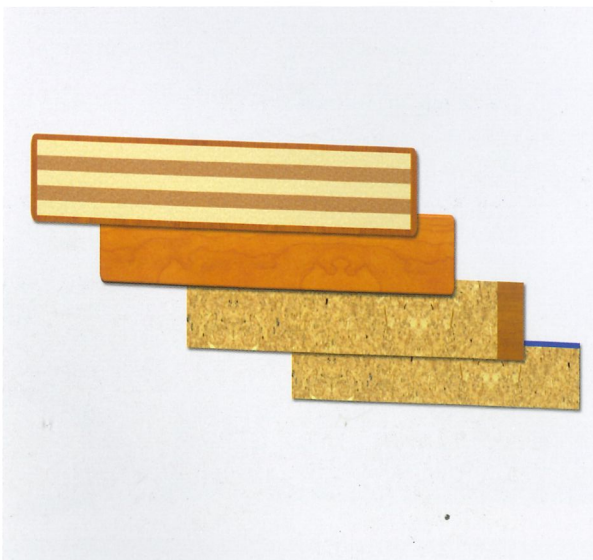
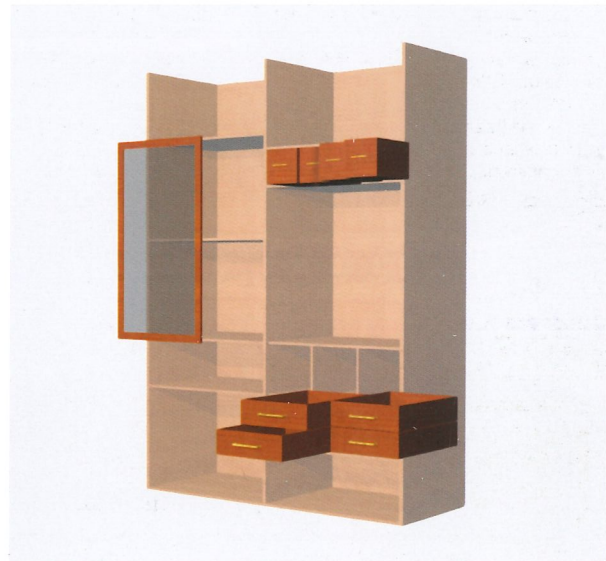

archivio di materiali e bordi
material and edging storage
archivos de materiales y cantos

lista di elementi con dimensioni e costi
parts list with sizes and costs
lista de elementos con dimensiones y costes

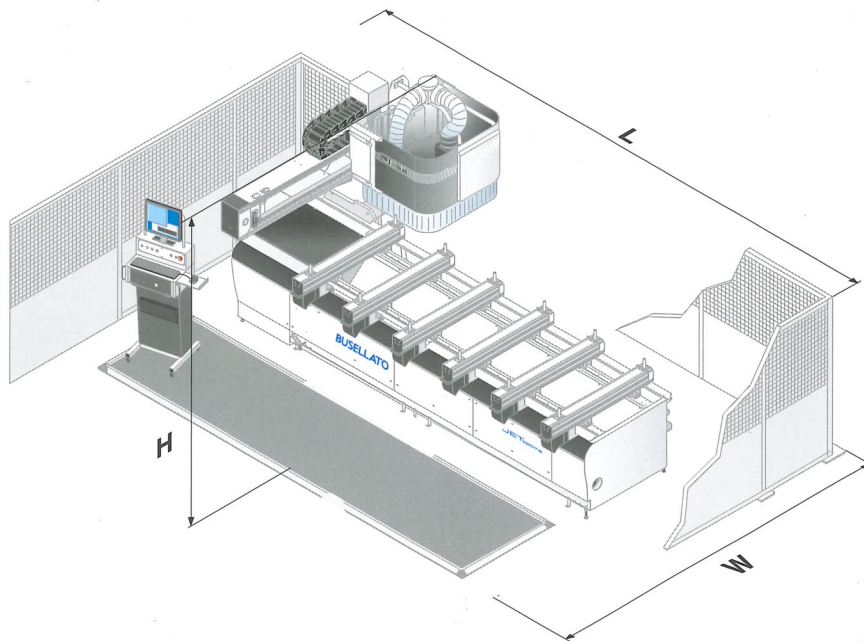

La ditta si riserva il diritto di apportare modifiche ai dati tecnici senza preavviso.
 The company reserves the right to modify the technical specifications without prior notice.
 La sociedad se reserva el derecho de modificar los datos técnico sin preaviso.

		L	W	H
OPTIMA C21	mm	5740	3825/4325	2450

OPTIMA C21

Corse assi - Axes Stroke - Recorrido ejes

Asse X - X Axis - Eje X	mm	3691
Asse Y - Y Axis - Eje Y	mm	1731
Asse Z - Z Axis - Eje Z	mm	300

Potenza max elettromandrino Max electrospindle power Potencia max electromandril	Kw	11
Potenza installata massima Max power installed Potencia maxima instalada	Kw	18
Capacità pompa vuoto Vacuum pump capacity Capacidad bomba de vacío	m³/h	90
Pressione aria compressa Compressed air pressure Presión aire comprimido	KPa	0,6
Consumo aria compressa Compressed air consumption Consumo aire comprimido	NI/1'	210
Attacco aria compressa Air connection coupling Conexión aire comprimido	Gas	1/2"
Diametro bocca di aspirazione Dust extraction outlet Diametro boca de aspiración	ø mm	200
Consumo aria aspirazione Extraction air consumption Consumo aire de aspiración	m³/h	3200/3400
Velocità aria aspirazione Extraction air speed Velocidad aire de aspiración	m/s	28/30
Peso macchina Machine weight Peso maquina	Kg	3000