

SERIE

# KA

## Top Calibrating Machines



SERIE

# KBA

## Bottom Calibrating Machines



SERIE

# KA

## Bottom & Top Calibrating Machines





# Machine frames (all with internal motors)

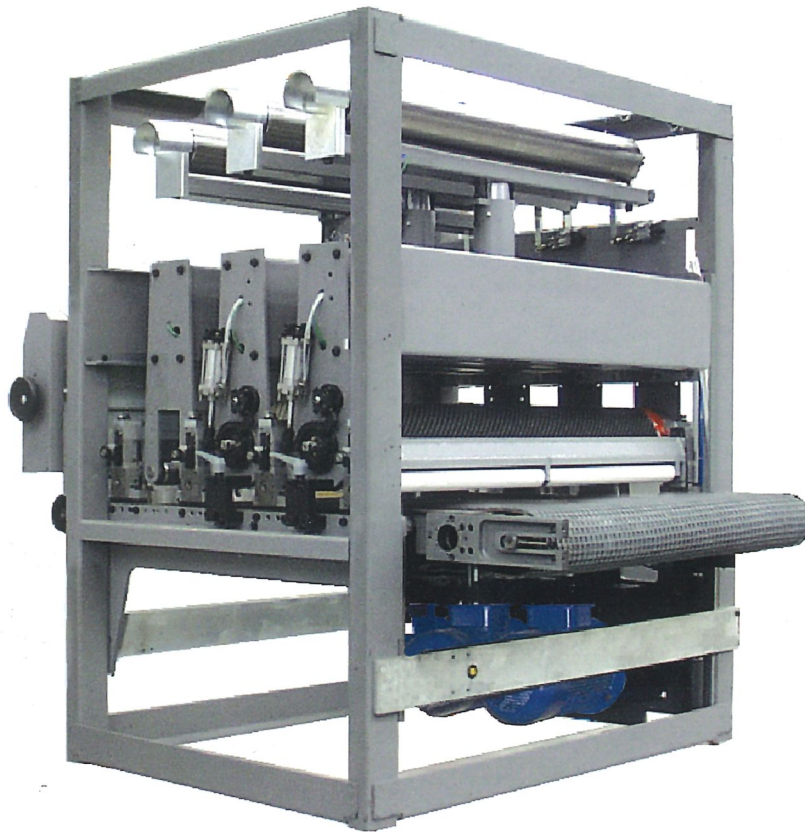

The rigidity of the frames is essential to guarantee a perfect calibration of panels - Heavy-duty steel columns are positioned at 4 sides and are interconnected with thick lateral beams to assure the highest level of rigidity.

Both top and bottom frames are foreseen to fit from inside the motors and power transmission of the working units, thus maintaining the noise inside the frames and leaving a free area on the machine sides.

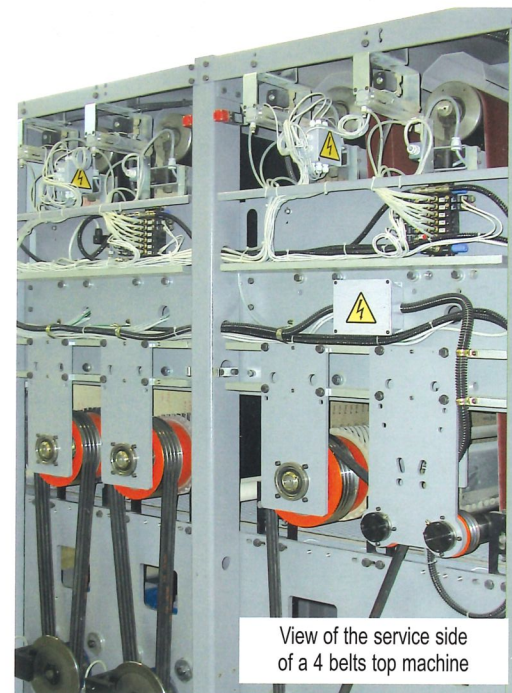
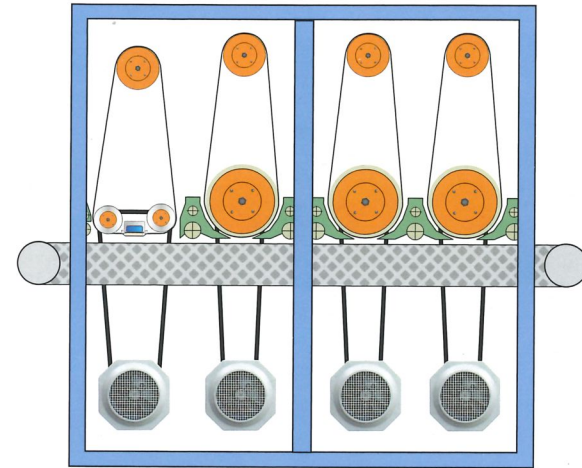

View of the service side of a 4 belts top machine

To assure the highest possible rigidity of the frame on the bottom machine and to guarantee a perfect calibration of panels to the standard steel columns positioned at 4 sides, we have added vertical supports to improve the rigidity between the working units.

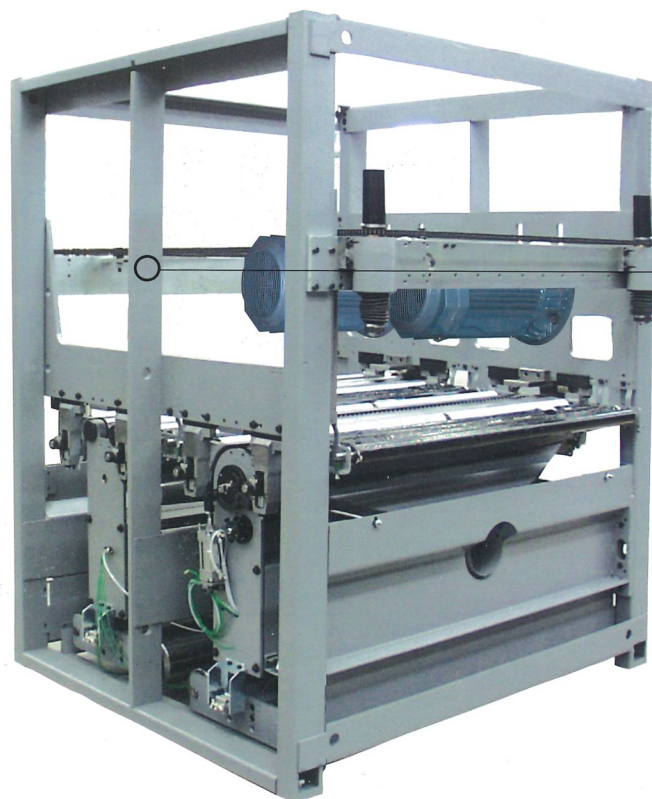
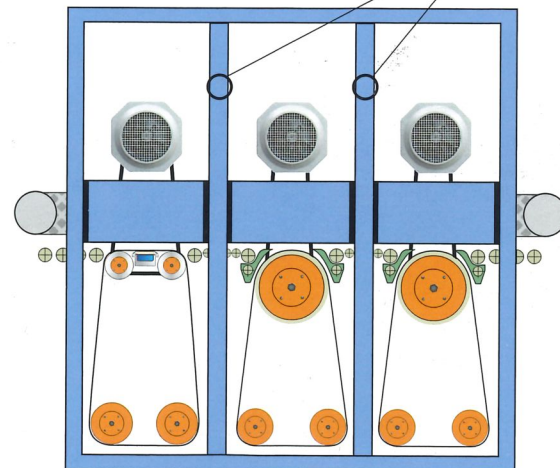

# Feed system

designed for heavy-duty purposes and long lasting

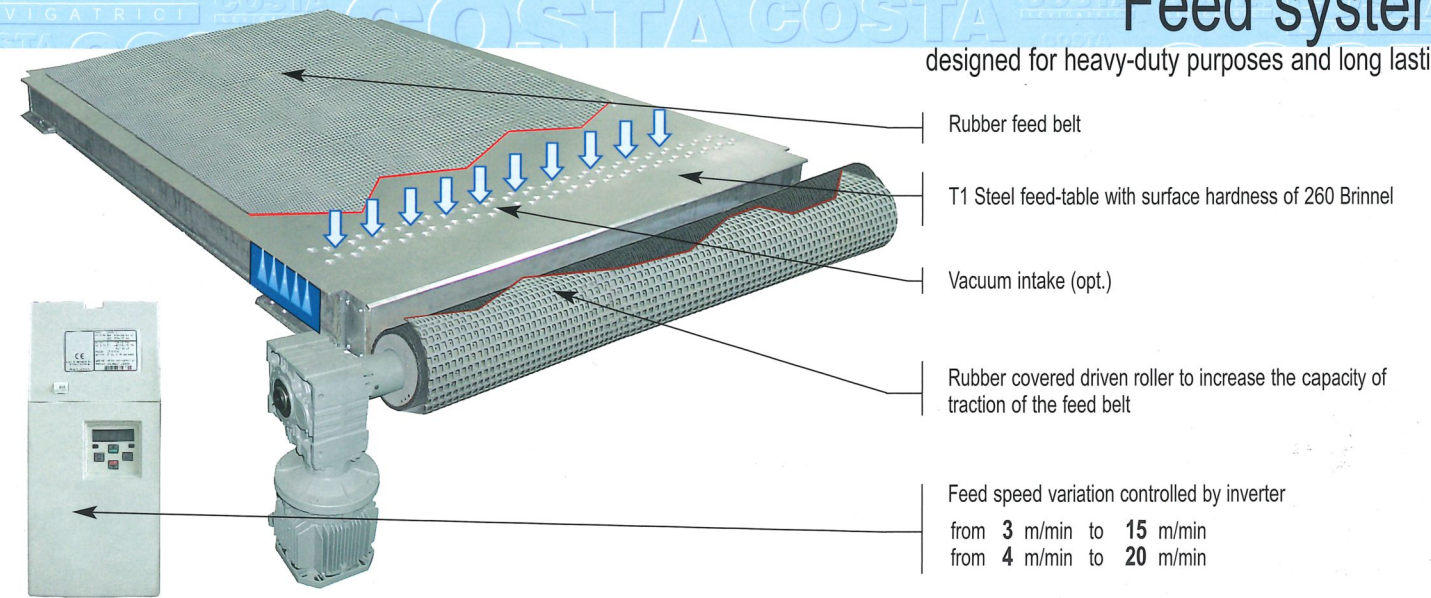

- Rubber feed belt
- T1 Steel feed-table with surface hardness of 260 Brinell
- Vacuum intake (opt.)
- Rubber covered driven roller to increase the capacity of traction of the feed belt
- Feed speed variation controlled by inverter
  - from 3 m/min to 15 m/min
  - from 4 m/min to 20 m/min

## A Feed belt

Accessories

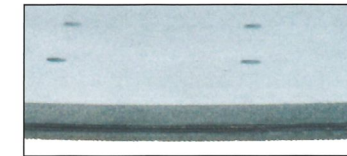

Flat

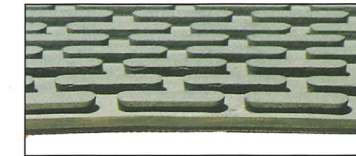

Raised lozenges pattern

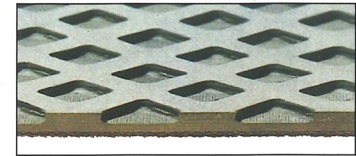

Small diagonal embossed squares (specific in case of vacuum device)

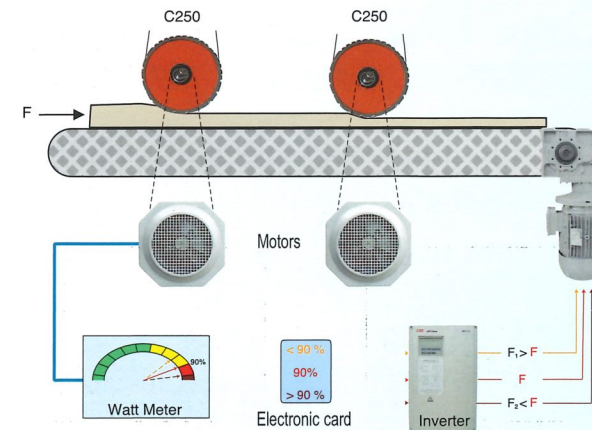

## AUTOMATIC FEED SPEED ADJUSTMENT

An electronic card is monitoring the power consumption of the first motor; as soon as the power exceed a certain step (adjustable from 80% to 95%), the system starts re-setting the feed drive unit in order to slow-down the feed speed, to bring the power to the maximum step pre-set. The system guarantee the correct machine utilization, without stressing the feed drive unit, the feed belt, the sanding belts, at the end it guarantees a high level of accuracy in the panel thickness.

## O Vacuum hold system

Optional

A high speed ventilator generates a strong pull under each working unit to secure the traction of slippery or short panels.



	Vacuum power		
working units	2	3	4
power needed [kW]	3	4	5,5

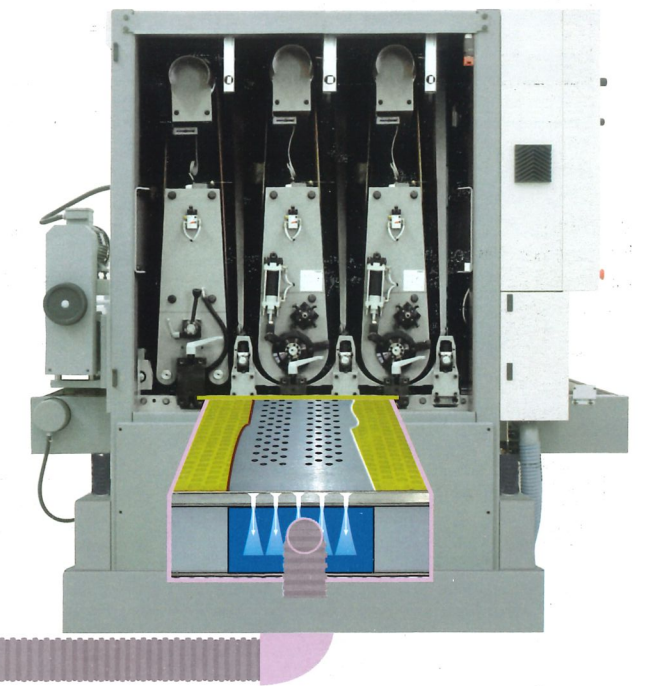



# Pressure units - to secure a good traction of the work-pieces

The safe traction of the work-pieces is determined by the rigidity of the pressure units ( that is their ability not to bend if stressed by heavy loads ), at same time they must be able to adapt to thickness variation of work-pieces.

## **A** Heavy duty pressure units with lips and rubber covered rollers

- dual setting purpose
- **elastic** (to allow panel thickness variation in calibrating mode)
  - **rigid** (to allow feed table flotation in fine sanding operation)

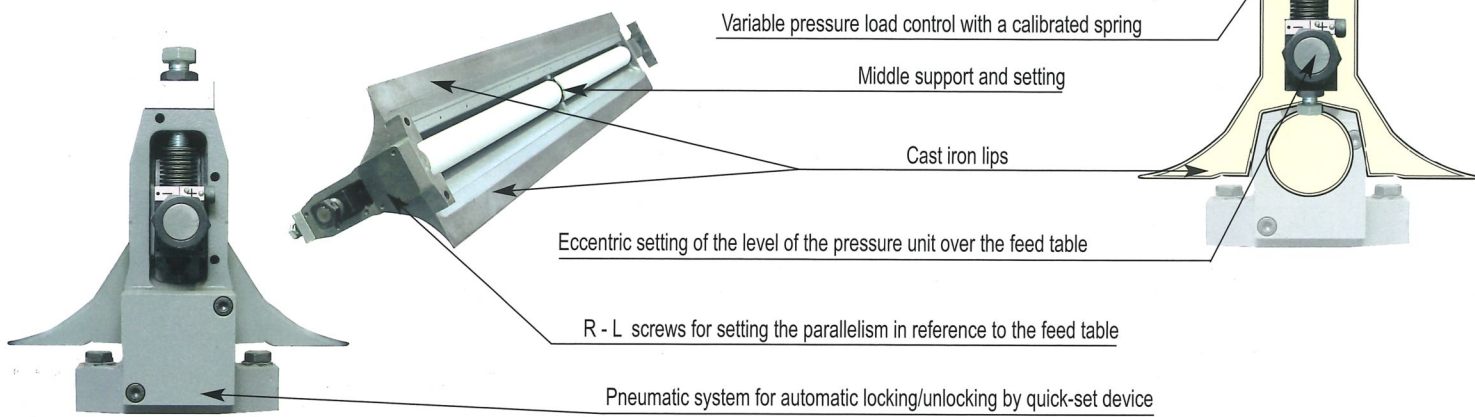

View of possible sequences of pressure units on top machines, with actual distances between the holding points (essential to establish the actual minimum length of work-pieces).  
The closer these pressure-holding position are, the better will be both the traction (of very short pieces) and the straightening action (on warped work-pieces).

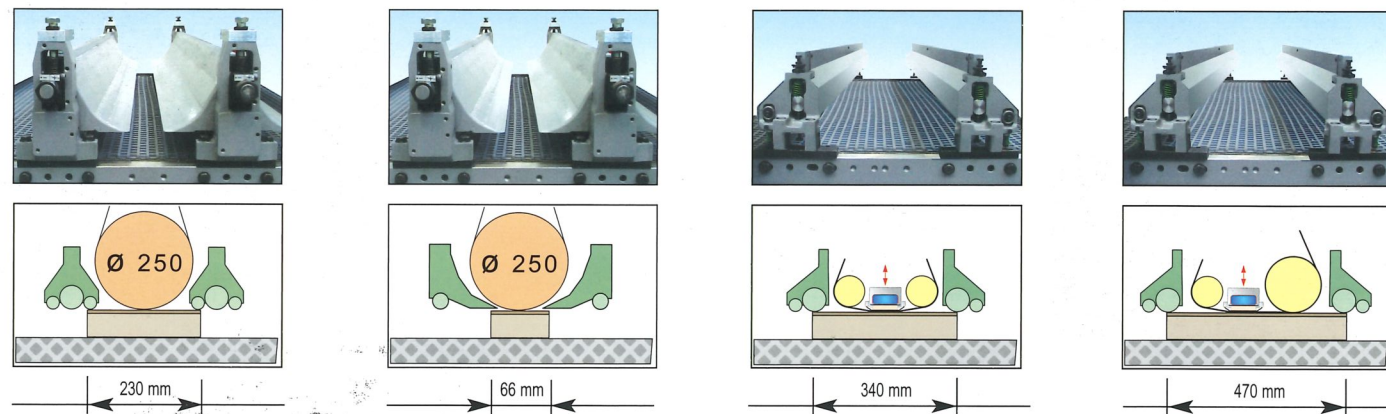
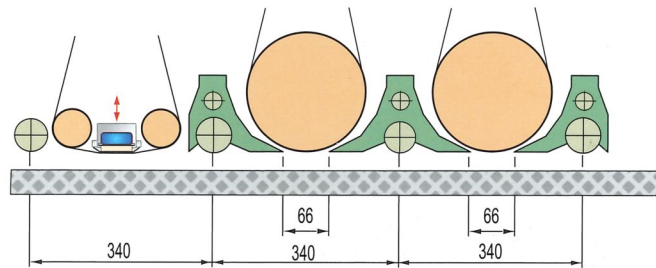

View of possible sequences of pressure units on bottom machines, with the rubber covered connecting rollers positioned between the working units.  
All holding rollers are mounted in re-adjustable supports on both sides of the machine, to allow eventual re-setting in case of dis-alignment

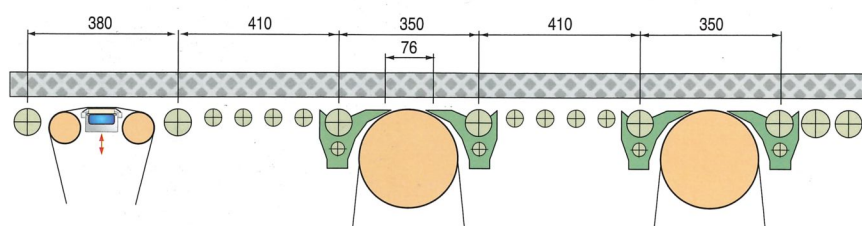

## Oscillating blowers



Oscillating air jet blowers for sanding belt cleaning, with high efficiency jets.



## Sanding belt oscillation system

Sanding belt oscillation system with electronic dual-photocell.  
Complete with safety micro-switch to stop the machine in case of misalignment or breakage of the abrasive belt.



## Disk brakes

Pneumatic operated disk brakes to stop the working units within few seconds from emergency.

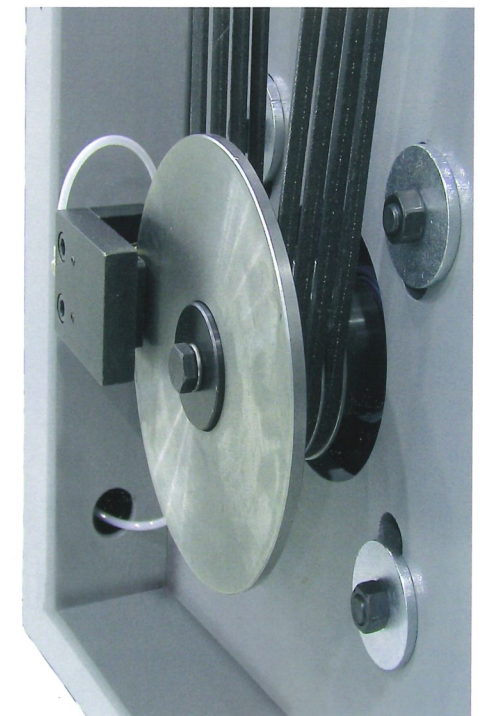

## Decimal thickness read-out



## Centesimal thickness positioning device

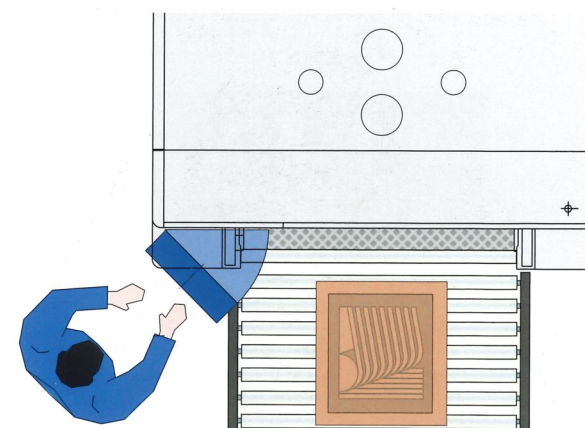

Possibility to have a 45° inclined panel board very usefull for machines positioned in line



# Other machine features



# KA - Top calibrating - sanding machines for lines

Series KA - Top calibrating-sanding machines for lines.

- available with 1 up to 4 working units.
- constant pass-line from floor.
- abrasive belt length 2620 mm;
- working width 1350 mm;
- thickness workable 0 ÷ 160 mm.



KA CT

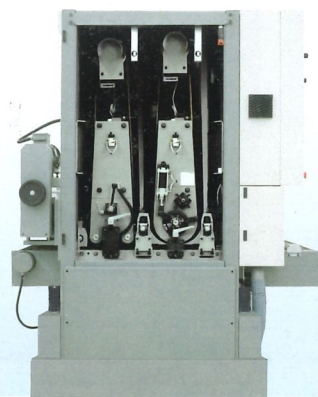

KA CCC

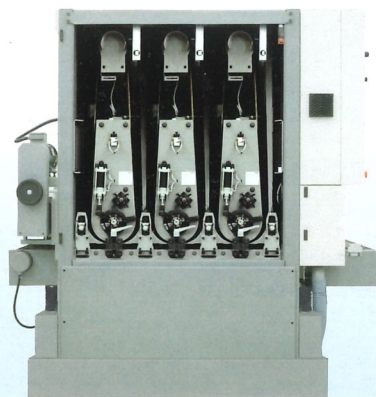

KA WCCT

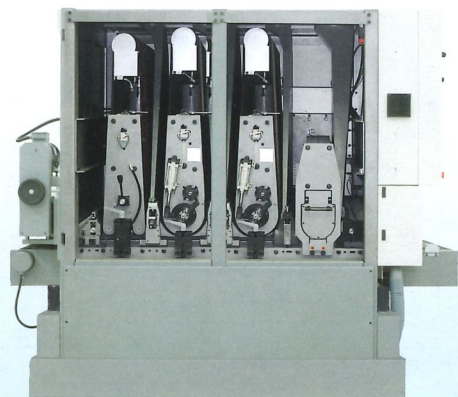

# KBA - Bottom calibrating - sanding machines

Series KBA - Bottom calibrating-sanding machines with constant pass-line from floor.

- available with 1 up to 3 working units;
- standard equipped with motorized in-feed table total length 1000 mm to easy the loading of work-pieces;
- constant pass-line from floor;
- abrasive belt length 2620 mm;
- working width 1350 mm;
- thickness workable 0 ÷ 160 mm.



KBA C

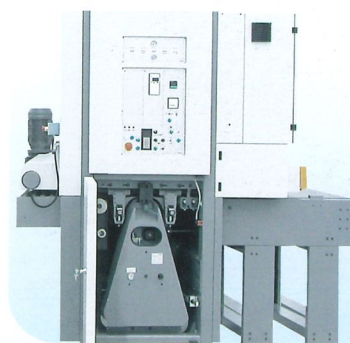

KBA CT

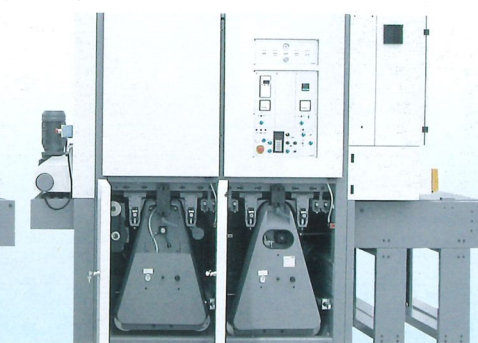

KBA CCT

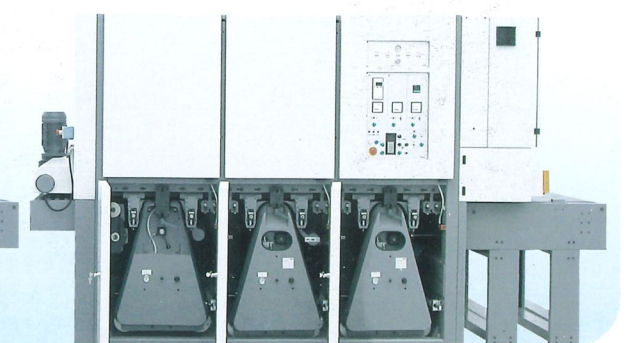



# KKA - Combined bottom + top calibrating - sanding machines

# KKA - Combined bottom + top calibrating - sanding machines

Series KKA - Combined bottom + top calibrating-sanding machines

Machines of Series KKA are obtained by linking machines of Series KA from 1 to 4 units, and bottom machines of Series KBA from 1 to 3 working units.

- infeed + intermediate driven feed tables each with a length of 1000 mm;
- centralized thickness adjustment with electronic programmer with 50 programmes;
- centralized feed speed adjustment from control panel of first machine;
- abrasive belt length 2620 mm;
- working width 1350 mm;
- thickness workable 0 - 160 mm.



The thickness positioning of the two sections of machines is made by a thickness programmer that can either split the take away in automatic or can give different values to bottom and top sections; - possibility to store up to 50 different pre-programmed positions.

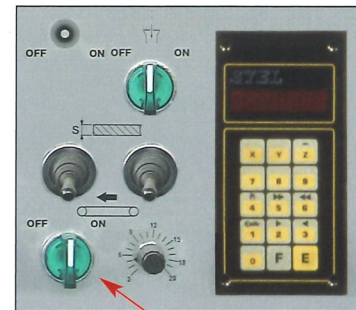

The feed speed of the bottom & top sections of KKA lines is kept constant by two vectorial inverters, one for each machine, linked by a "master-slave" process of electronic synchronization.

**SCHEMA OF THE DIFFERENT UNITS INVOLVED IN THE FEED SYSTEM AND IN THE HOLDING OF THE WORK-PIECES IN THE LINE OF BOTTOM+TOP MACHINES OF SERIES KKA**

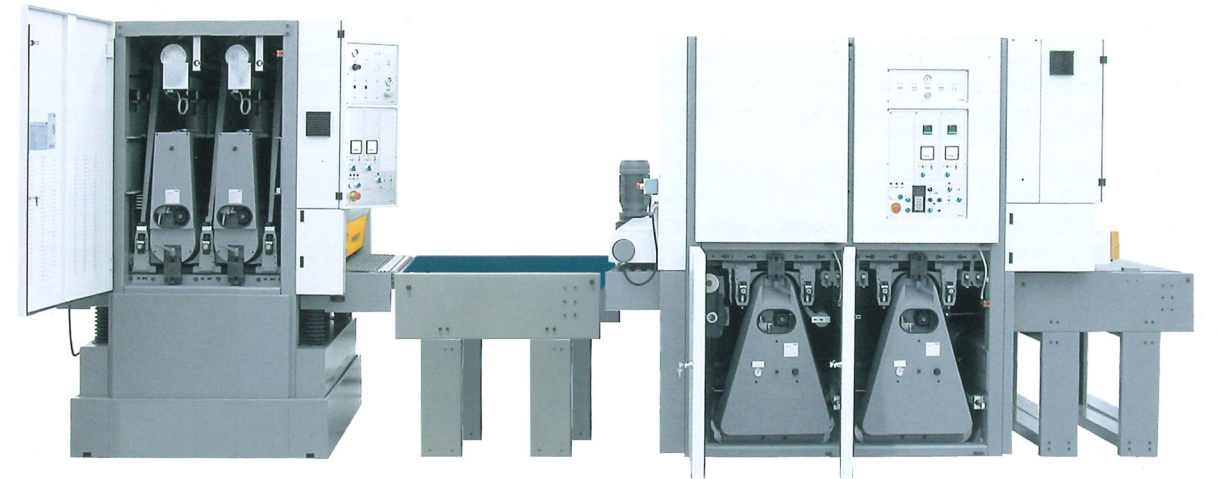
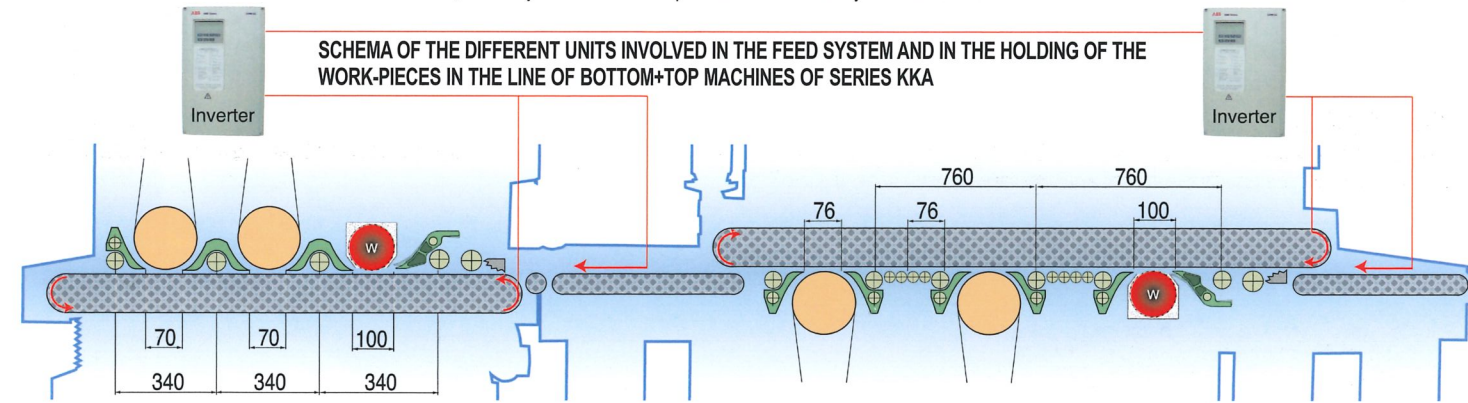

## KKA CC-CC

Obtained by the combination of bottom machine (KBA CC) and a top machine (KA CC); between the two machines there is a driven transfer table length mm. 1000 (standard). - Optional are longer size feed tables, needed when the panel length is longer than 1300 mm.

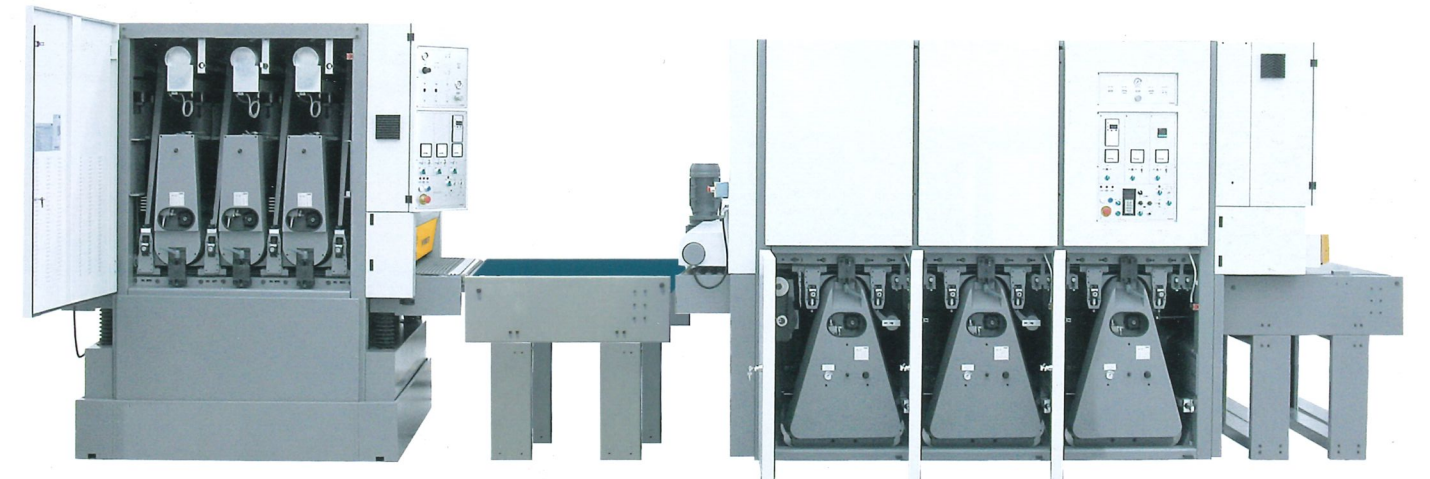

## KKA CCC-CCC

Obtained by the combination of bottom machine (KBA CCC) and a top machine (KA CCC); between the two machines there is a driven transfer table length mm. 1000 (standard). - Optional are longer size feed tables, needed when the panel length is longer than 1300 mm.

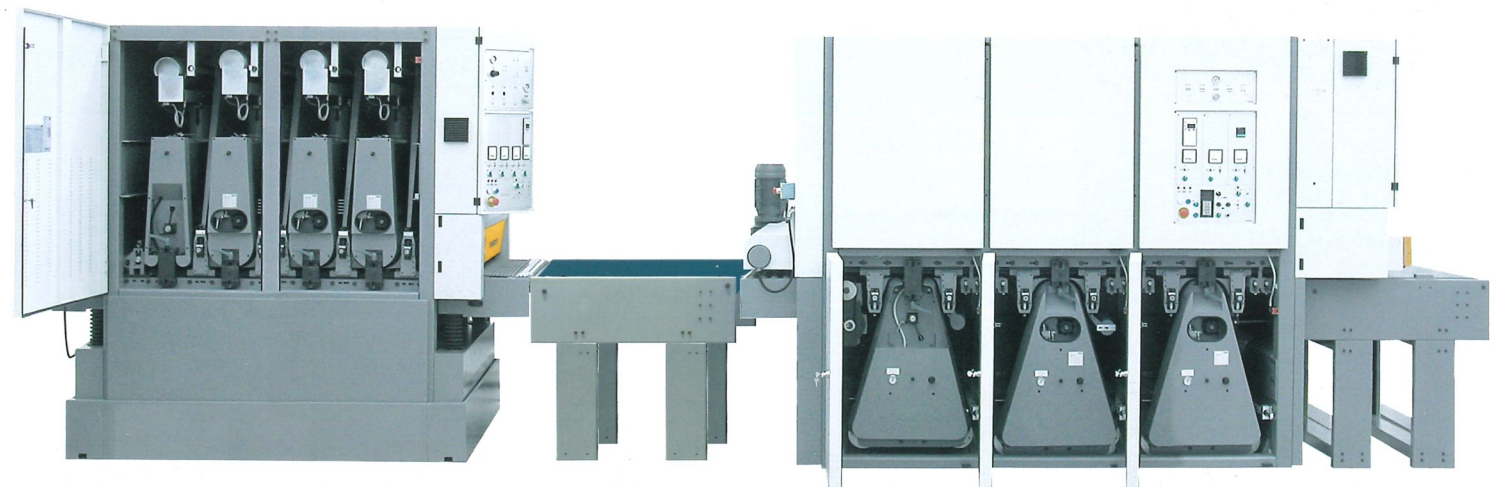

## KKA CCT-CCCT

Obtained by the combination of bottom machine (KBA CCT) and a top machine (KA CCCT); between the two machines there is a driven transfer table length mm. 1000 (standard). - Optional are longer size feed tables, needed when the panel length is longer than 1300 mm.



# W180E

## Planer head - from 0.5 to 5 mm of take away

These are equipped with a planer-head unit W180-8 in the first position. The planer head W180-8 has a diameter of 180 mm with 8 rows of tips, set helicoidally and with inclined cutting edge in order to have a smooth impact.

Many the advantages in processing of solid wood panels with W180:

- possibility of high amount of take away (impossible with sanding belts), "normal" from 0,5 to 1,5 / 2 mm, and up to 5 mm when needed.
- low motor power usage, 22 kW. is the normal motor size.
- feed speed of production variable from 4 to 8 / 12 m/min (in relation to width and take away).
- low cost of tools, one set of tips lasts for hundred of thousands of meters in a ratio 1 to 20 (in comparison to sanding belts in the same operations and conditions).
- very low sanding belt wear (only utilized for finishing).
- high level of surface finish, the first sanding belt after the planer starts with grit 100 / 120, the second can finish with grit 150.
- good thickness tolerance of panels processed with 1 planer and 2 belt units is  $\pm 0,1$  mm.

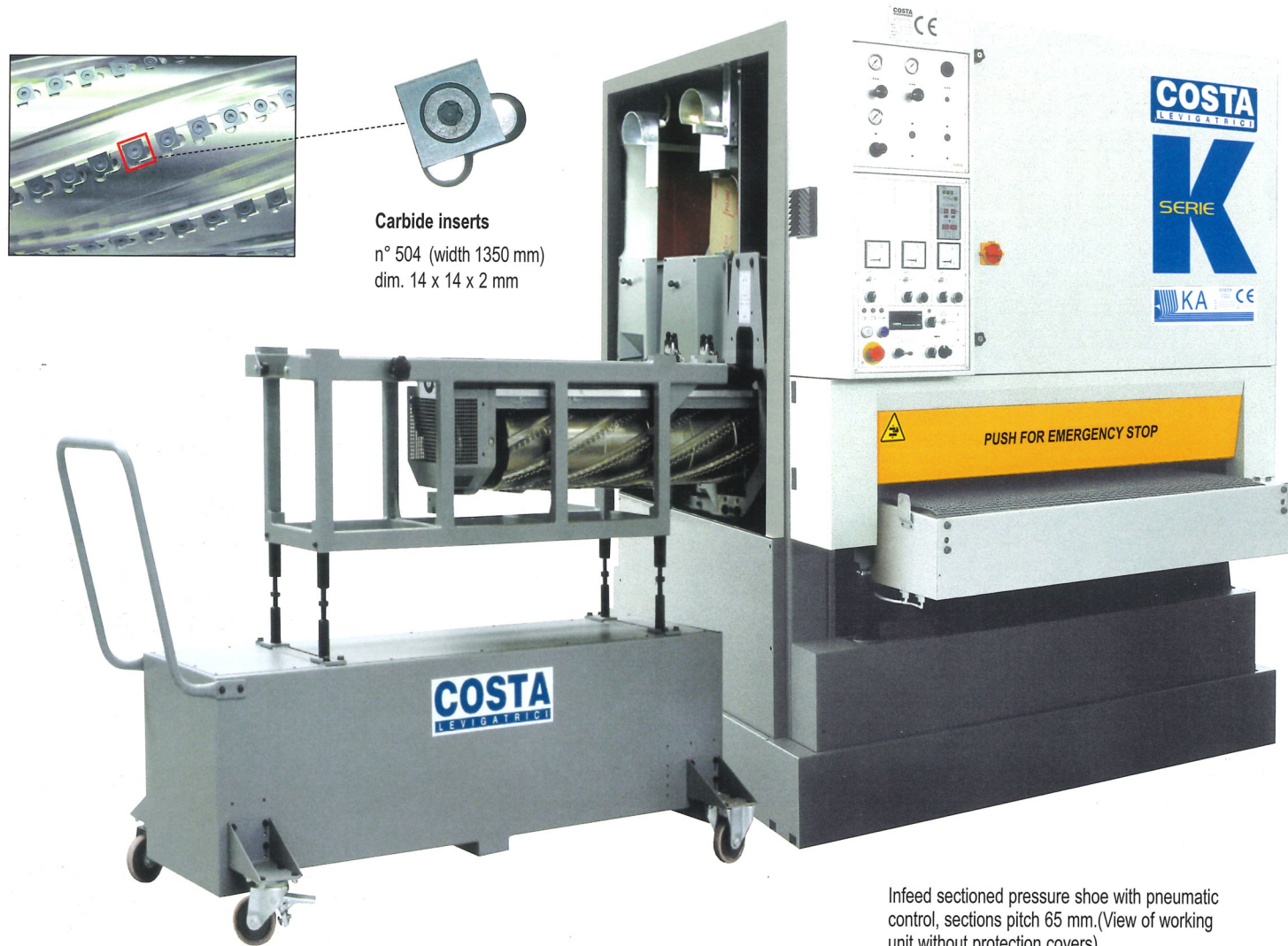

**Carbide inserts**  
n° 504 (width 1350 mm)  
dim. 14 x 14 x 2 mm

Infeed sectioned pressure shoe with pneumatic control, sections pitch 65 mm.(View of working unit without protection covers)

In front of our planer head units, we have 4 lines of safety:

- 1° - a first rubber covered roller with safety limit switches to stop feeding over-thick panels;
- 2° - one set of anti kick-back hardened steel sections;
- 3° - another big diameter rubber roller;
- 4° - the sectioned pressure units pneumatically loaded to distribute the pressure evenly in all width of work-pieces without overloading the feed belt/drive unit.

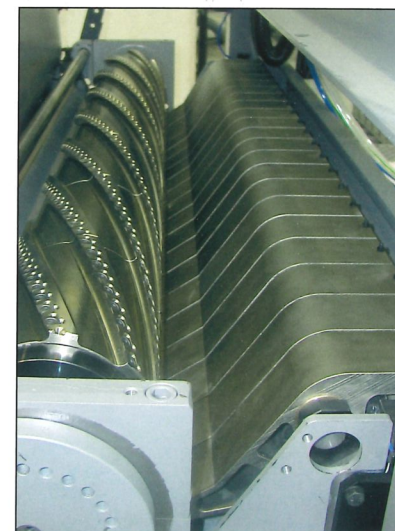
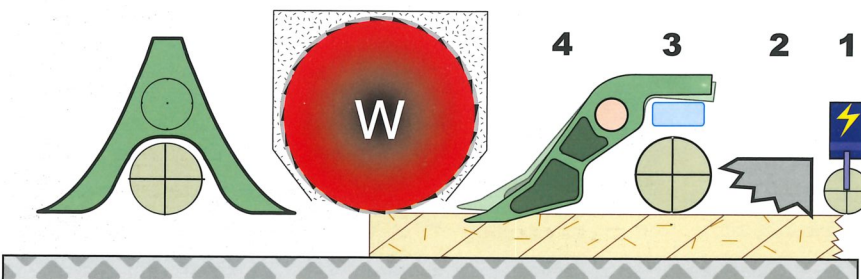

# C250 - C330

## Cylinder units

A wide abrasive belt runs on a rubber covered (or steel surface) cylinder.

The rubber harnesses determines the level of adaptation of the sanding action of the cylinder on the panel surface in white-wood/lacquer operations; a soft rubber covered cylinder has more adaptability to the unevenness of the surface therefore is better for veneer-lacquer sanding operations, while a hard rubber cylinder has less or no adaptability to the surface (thus better for calibrating operations).

The main feature of the cylinder unit is the higher capacity to "take away" with same sanding belt grit, compared to any other sanding media.

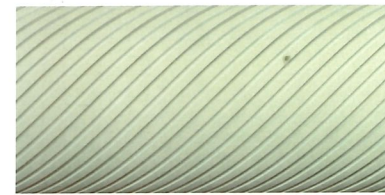
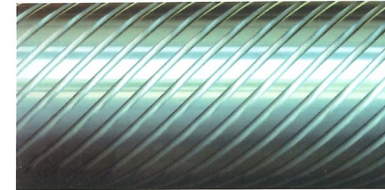

Special type of helicoidal grooves on the surface of the cylinders for cooling and for air discharge

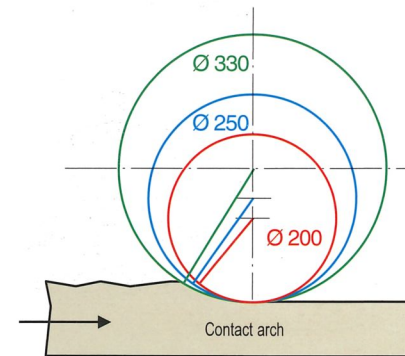

The **Grit-Set** - Pneumatic or Electronic- is very useful to visualize the working height and to position with accuracy the cylinder at a correct level in all working operations.

**GSE** Electronic Grit-Set - centesimal positioning of the working level of the cylinder unit.  
Exclusion of cylinder in emergency (stand-by) (opt).

**GSP** Pneumatic Grit-Set - to position by pre-set steps the working level of the cylinder unit.  
Exclusion of cylinder in emergency (stand-by) (opt).

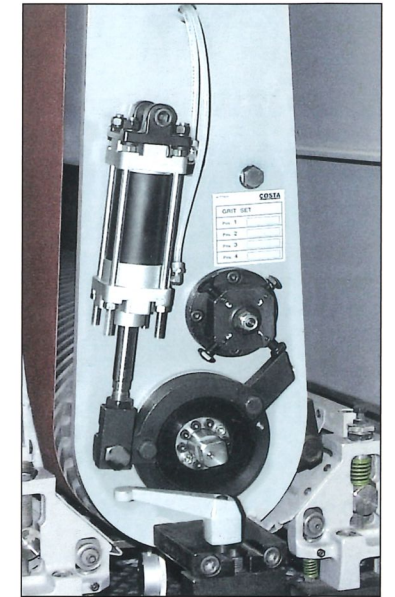

For **calibrating** a smaller diameter cylinder is more aggressive, the angle of contact is more open, the surface of contact is narrower, this means less friction and more take away.

For **sanding** a bigger diameter means more surface of contact, more quantity of rubber (longer lasting time).

# CK

## Combined unit (cylinder+pad)

A cylinder C200 is inserted together with a pad T1 in the same abrasive belt unit, with the possibility to use either one or the other or both at same time.

• **C200** cylinder ø 200 mm rubber covered (hardness 20 ÷ 90 shore) or steel, with in-out positioning of the cylinder (optional grit-set electronic or pneumatic).

• **T1** pneumatic pad unit with electronic time-entry control (optional are the electronic controlled sectioned pads TP16 and TP32).

Support on a revolving turret at 4 preset positions

Pneumatic Grit set

T1 pneumatic pad





# T1 - TP32 - TP16

## Pad working units

This is the classic sanding unit for finishing the surface, as they are able to compensate thickness and planarity differences of the panels. In this unit the sanding belt is pressed down to the panel surface by a number of contact elements at variable intensity of pressure. The wide surface of contact of the pad unit gives a flat look to the panel surface. For an ideal protection of edges and corners of panels we recommend the sectioned pads with electronic control of the timing of intervention and of the pressures of utilization.

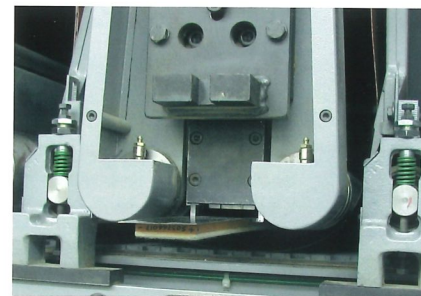
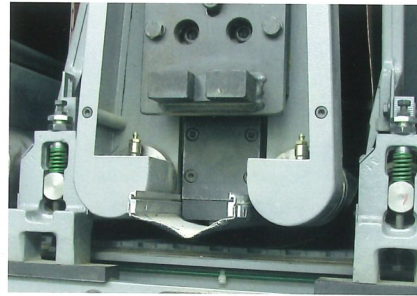

Quick - easy change of graphite cloth and inspection of the felt-rubber and the steel blade inserts

### TP32 - TP16 Electronic controlled sectioned pad

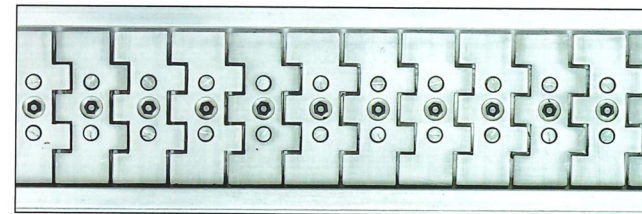

**TP32** • pitch of sections 32 mm  
n° 42 sections with a working width of 1350 mm

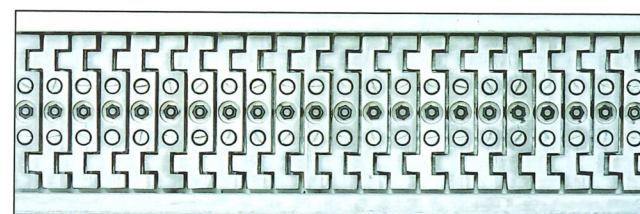

**TP16** • pitch of sections 16 mm  
n° 84 sections with a working width of 1350 mm

The electronic controlled sectioned pad system of sanding requires all its elements to operate in absolute coordination and to be of the highest quality to obtain the best finish result on the panels surface. The following scheme visualizes all its components, all fully interconnected to form one only working system, where each item must correspond perfectly to the general functionality to obtain the best sanding result.

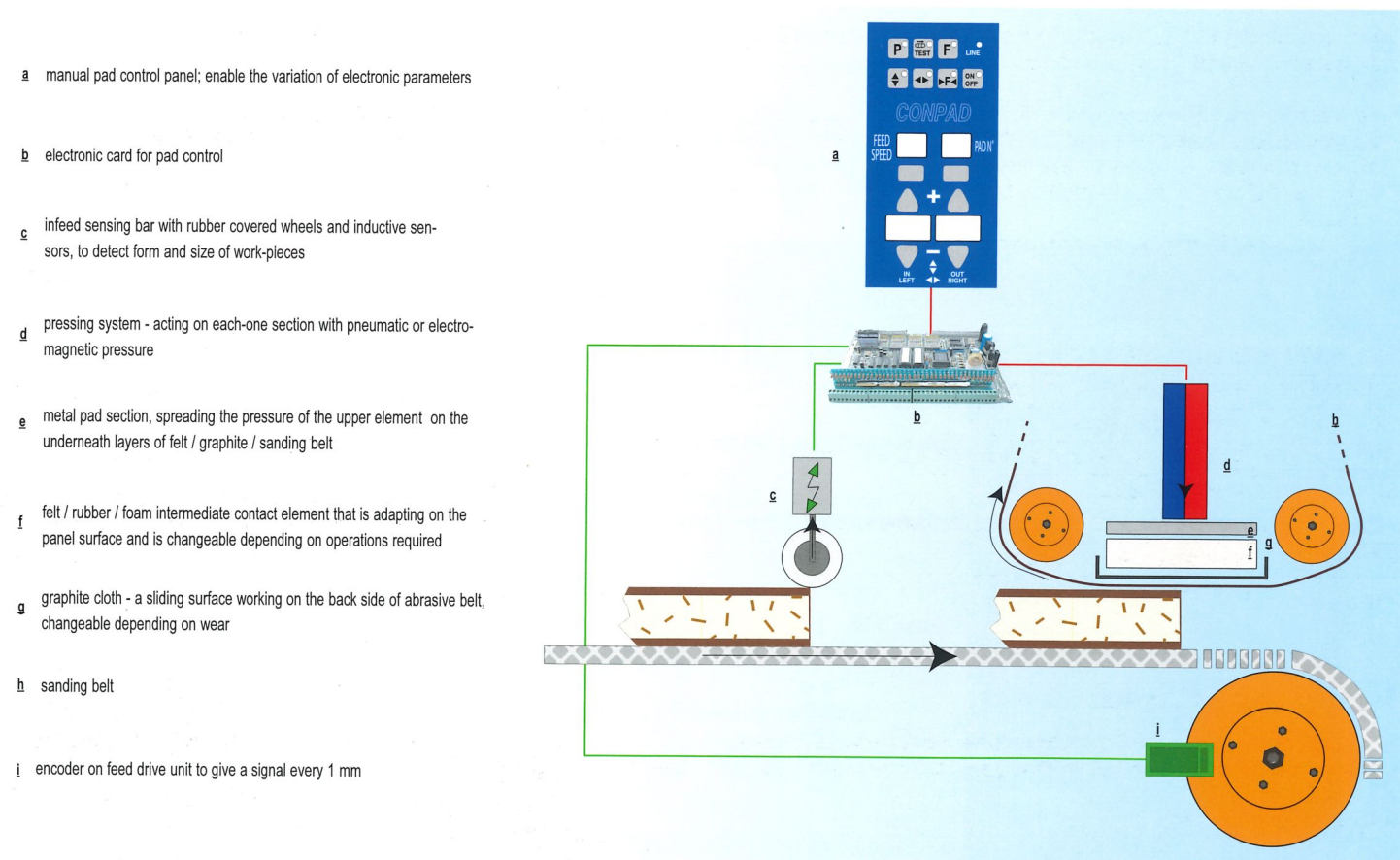

# SB250

## Scotch-brite™ unit

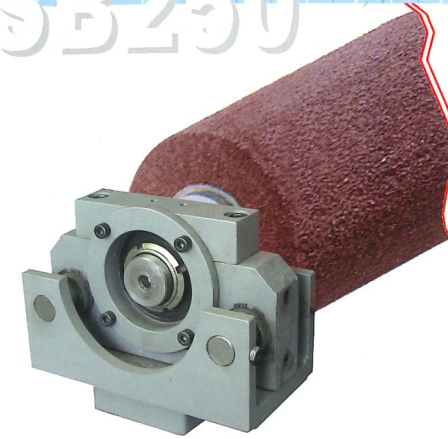

These working units are utilized to improve the sanding and to finish the lacquer surfaces. The scotch-brite brush has a structure of non-woven synthetic fibres impregnated with abrasive grain of aluminium oxide or silicon carbide, the rollers are available in variable grit ( 80+1000 ) and various density.

# S180

## Finishing and cleaning panel units

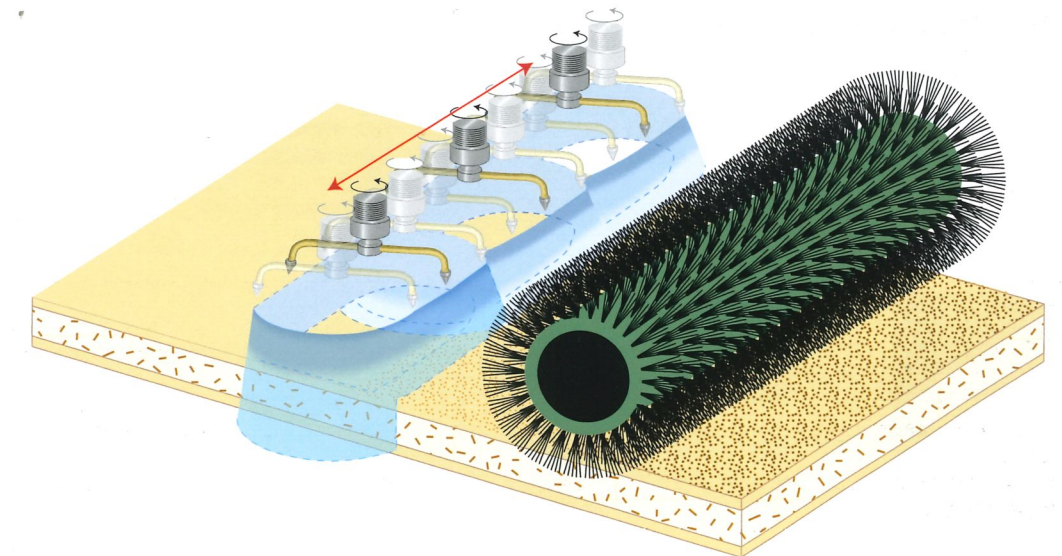

Very often the sanding machine is integrated in complete working lines (lacquer lines) therefore it is very important that the panels are perfectly cleaned. In the rear side of the machines we can install different "panel cleaning units":

- the scotch-brite brush is an aggressive and effective unit to clean the lacquered surfaces from the fine dust generated by sanding with very fine sanding belts;
- the normal brush is cleaning the heavier dust with bristles either in nylon or vegetal fibres or even with horse-hair bristles to diminish the build up of static electricity;
- the rotary blowers are helping to blow away the very fine dust from the surface as well as from the sides of the panels;
- a new version of rotary blowers with lateral oscillation system are fitted with jet blowers with special nozzles that can blow away more effectively the dust from inside the holes of the panels;
- antistatic bars help lowering the static electricity from the panels.

- S180 / S250 • Brush unit Ø 180 / 250 mm made in nylon or vegetal fibers
- SB180 / SB250 • Scotch-Brite™ unit Ø 180 / 250 mm Scotch-Brite rollers™ of various density
- SR • Stationary rotary blowers
- SRO • Rotary blowers with lateral oscillation of the blowing units
- SJ • Blowing ionizing bar to lower the static electricity accumulated during working process
- SJ1 / SJ2 • Single and double antistatic bars
- SL • Linear oscillating blowers

### Feed belt cleaning blowers

To clean the feed belt, we position in the bottom side the "oscillating cleaning blowers". Connected to a timed entry system, they are blowing a moisture of air + water to increase the level of grip to the feed belt. A dust hood complete the unit.

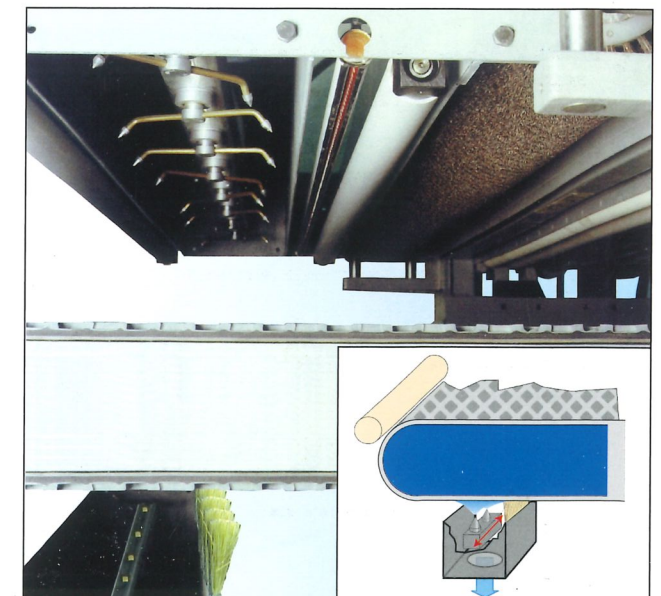





## Electromechanical Panel

Control panel positioned in front of the machine, with push-buttons for all motors and amp-meter readers of power utilization of the working units.  
 Digital positioner with read-out of the thickness adjustment with decimal accuracy.  
 Emergency stop and reset  
 Range change switch for the variation of the feed speed  
 Diagnostic leds of electric-pneumatic-safety problems



1



## START - PLC control panel with global visualization of functions

START is a plc control system, with digital board positioned in machine front side equipped with: push buttons and amp-meter read-out of the power utilization for each working unit; read-out of the position of each grit-set (for cylinder units) and setting of parameters of pad working units; automatic setting of the panel thickness with decimal accuracy and digital read-out.  
 All machine functions are visualized and memorized in the START plc.  
 The initial configuration and eventual modifications are inserted manually and they can always be recalled by a code; these data are automatically transferred, in a pre-defined sequence, to the machine starters by a single pressure of the Start cycle button.  
 The START panel can store up to 9 complete working programmes in its plc.



2



## PCM - Computer control with monitor on board of machine

"Easy" Personal Computer System, operating with Windows, is complete with a Costa Sanding Manager, the standard programme for total machine control.  
 It's possible to choose between "TOUCH SCREEN" and "FINGER MOUSE".



3

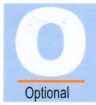

## PC3 - Computer control with interconnecting possibilities

Computer controlled machine, with monitor and keyboard positioned in a separate column  
 This is a PC working position integrated in the company network.  
 The PC control system allows to pre-set all the working programs; besides the usual controls of the machine, it can also supply complete production data such: number of pieces processed, working time per each code, square meter produced, compressed air, volume of dust extraction, electric power consumption, etc..  
 Through a modem we have the possibility to connect directly Costa Service for help and service

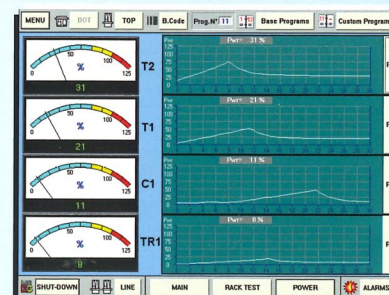
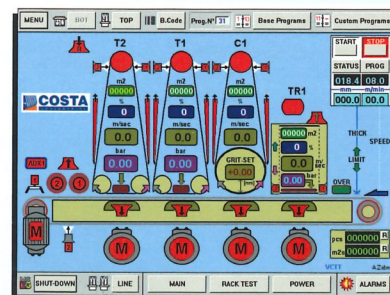

4

## instruction books

With every machine we supply 1 book of instructions for utilization and maintenance, with included all electric and pneumatic schemes (as per CE regulations).  
 Our PC are complete with same full instructions for utilization and maintenance, all electric and pneumatic schemes that can be recalled directly on monitor to be consulted on requirement

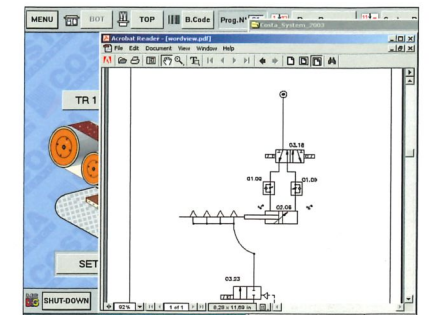
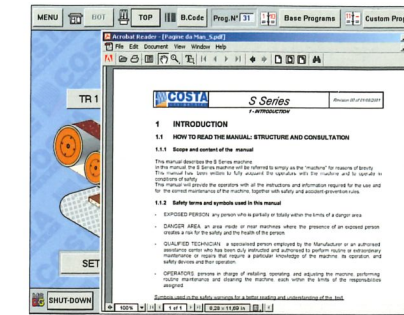

## instruction training of operators

Costa Levigatrici supports a net of "Costa Service Centres" run by technical personnel that have been working and have specialized in our production plants, to install machines, give operating instructions and training to the machine operators directly in place of utilization.

Training courses for operators are regularly held in our factories, and we encourage Customers to send the operators to assist to the final stage of machine assembly-testing in our factories, to receive all instruction for machine utilization and maintenance.



## after sales - service and spare parts

**SERVICE NET** - The "Costa Service Centres" are equipped with full spare parts stock, they possess a copy of the instruction books and spare parts of all machines sold in their areas of operation.

**PC LINK** - Costa Levigatrici has been first to make possible the service of its sanding machines equipped with PC with a direct connection. The possibility to be in direct communication via Internet with the PC of our machines, allows our After Sales Service a low cost system for data exchange, that make possible the loading of new working programs, check the maintenance of the machines, help solving production problems and help operators and service personnel.

**DIRECT SERVICE CENTRE SCANDINAVIA**  
**COSTA SWEDEN**  
 Islandsgratan, 3 - S - 50432 BORAS  
 tel. (+46) 33 228190  
 fax (+46) 33 228191  
 www.home.swipnet.se/costa/  
 e-mail: costa.s@swipnet.se

**DIRECT SERVICE CENTRE NORTH AMERICA**  
**COSTA & GRISSOM MACHINERY CO. INC.**  
 107 Seminole Drive - ARCHDALE, N.C. 27263  
 tel. (+1) 336 - 434 - 6644  
 fax (+1) 336 - 434 - 6656  
 www.costagrissom.com  
 e-mail: sales@costagrissom.com

**SERVICE CENTRE SOUTH AMERICA**  
**MAC LINEA S.A.**  
 Av. das Industrias  
 2420 CIC CURITIBA, PR  
 tel. (+55) 41 346 3938  
 fax (+55) 41 246 4345

**DIRECT SERVICE CENTRE ASIA**  
**COSTA S.E.A. SDN BHD**  
 N° 24 Jalan 6/118 C Desa Tun Razak Industrial Park  
 56000 CHERAS, KUALA LUMPUR  
 tel. (+60) 3 - 973 6743  
 fax (+60) 3 - 973 6745  
 E-mail: costasea@tm.net.my

**DIRECT SERVICE CENTRE AUSTRALIA**  
**VILLE - TEC ENGINEERING & REPAIRS**  
 38 Gibson Avenue PADSTOW NSW 2211  
 P.O. BOX 295 ROCKDALE NSW  
 tel. (+61) 02-9790 7953  
 fax (+61) 02-9588 5953  
 ville\_tec@bigpond.com

Our machines are built according to American Standard **UL & CSA**

Our machines are built according to European Standard **CE**

On request the machines can be built in different standard





# The other lines in our range of products:



Universal Sanding-Calibrating Machines



Sanding Machines



Sanding-Calibrating Machines

- Top Machines
- Bottom Machines
- Top+Bottom Machines



We reserve the right to change features without any notice



COSTA LEVIGATRICI S.p.A.  
Via Venezia, 144 - 36015 Schio (VI) Italy  
Tel. (+39)0445-675000 - Fax (+39)0445-675110  
www.costalev.com - info@costalev.com