

PRO-MASTER PRO-MASTER XL

The standard for High
Performance CNC machining

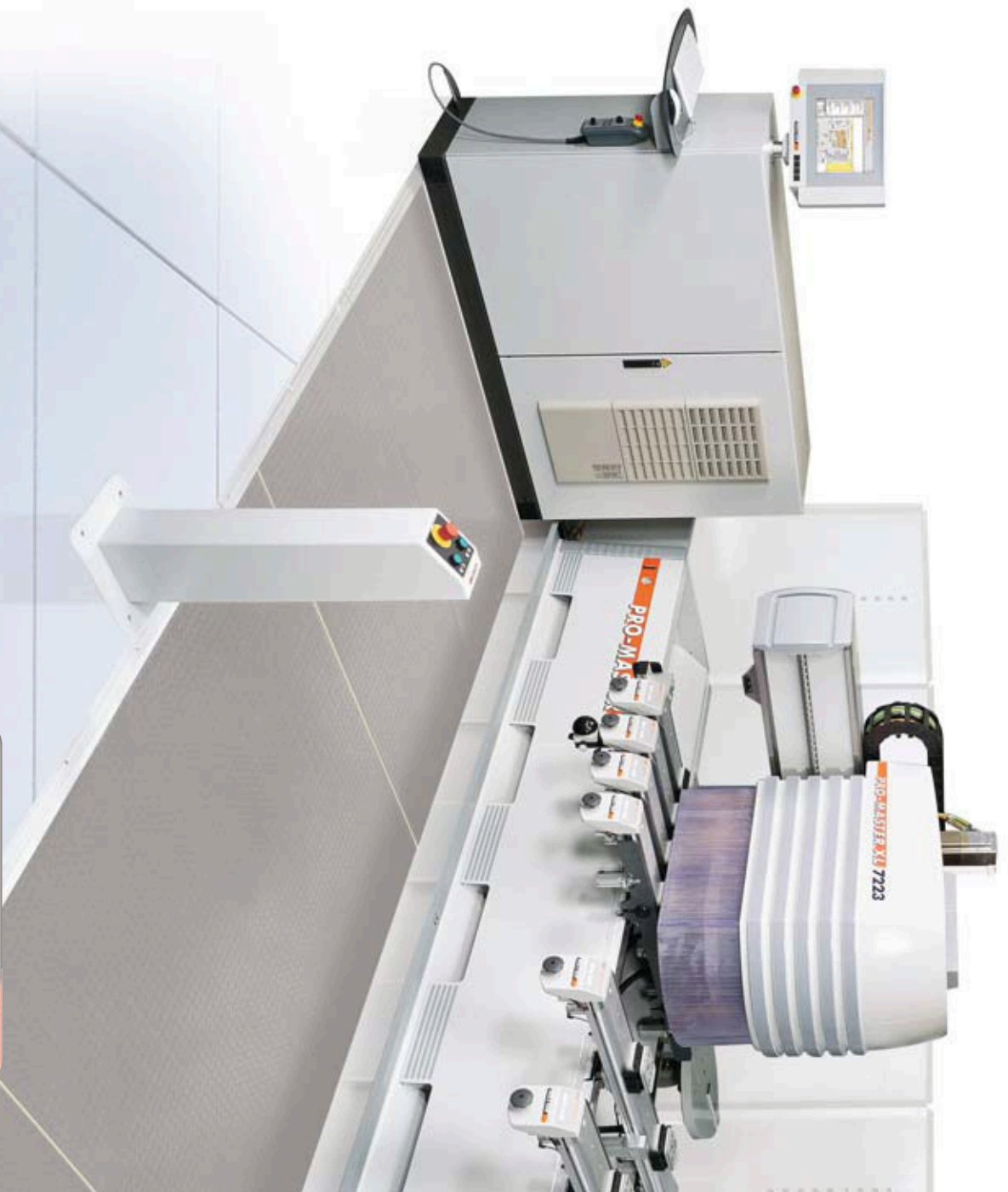

Your partner for productivity and precision

HOLZHER
Special Machines

www.hoechsmann.com

Superior in terms of performance and equipment

Two machine sizes – double perfection

- The stability of the PRO-MASTER/XL cantilever arm has been optimised using the “finite element method”. This permits a high load on a low weight, which allows extreme acceleration values and structural strength.
- Precision, running quiet and a very long service life.
- High-quality, powerful drive and transmission technology provides the extreme acceleration values and the rapid displacement speeds of the PRO-MASTER series.

Oblique and polished teeth ensure exact positioning accuracy and quiet running. The high quality of the material ensures minimum wear and a long service life.

The PRO-MASTER and PRO-MASTER XL from HOLZ-HER set the standards for economic and highly flexible CNC machining. The performance spectrum of these machining centers really hits the mark:

- Quick machining speed
- High above-average precision
- Simple, ergonomic operation

The absolute concentration on practical requirements make the PRO-MASTER series unique in its price class and make it the perfect machining center for all companies which operate in a highly flexible manner or which have high production requirements.

The basic frame with its strong, compact structure and the moving stand in the one-arm design – both welded constructions – guarantee superior stability. Together with the polished and hardened prismatic guides, this forms the basis for the precise operation of the powerful units. A 3-field safety foot mat makes pendular machining possible. In the optional 5-field version, the foot mat offers even greater freedom of movement, specifically for very long machine table versions.



PRO-MASTER XL – opens up new dimensions

The PRO-MASTER XL 7223 is unbeatable in terms of the combination of technology, displacement travels and price/performance ratio. The drive in X and Y takes place via a rack-and-pinion mechanism and ensures extremely high precision at high accelerations and speeds. The large displacement travels in Y and Z open up new machining dimensions.

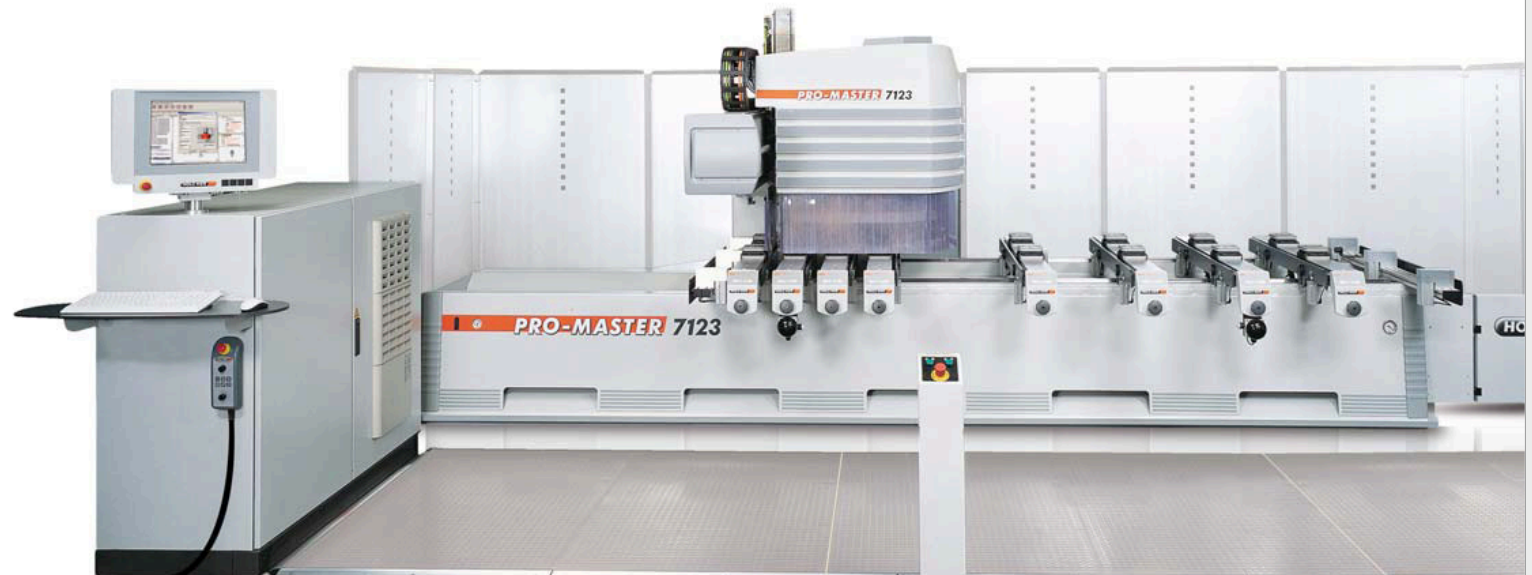



Automatic clamping mechanism

- Solutions consisting of a wide range of available clamping and fixing systems.
- Stable support and secure hold for each workpiece.



CONSOLE TABLE

Ergonomic and easy handling

- Measuring tape indicators for rapid positioning of consoles and vacuum suction pads. A digital display which is fitted ergonomically to the end side is available as an option for each console. Information regarding the nominal positions of the consoles, suction pads and types of suction pad are provided online from the control system, where the user defines them.
- The spacing between the solenoid valves is optimised to the size of the vacuum suction pads. The advantages are that all positions on the consoles can be reached and the suction pads are positioned close to one another.
- The consoles can be displaced in the X direction on polished and hardened linear guides. Both right-handed and left-handed operators can easily release and clamp the consoles pneumatically at the touch of a button. Four pneumatic loading aids which can be raised and lowered make the handling of heavy workpieces seem like child's play.

Console table – workpiece support for optimal working procedures

Precise machining requires exact and secure positioning of the workpieces. In order to further improve working procedures for the wide range of applications in industry, the PRO-MASTER/XL is available with four different workpiece supports. In its basic version, the PRO-MASTER series is equipped with a console table.

- It offers high flexibility in the machining of workpieces in panel form.
- Even workpieces of complicated shape can be fixed quickly and easily.

- The console table of PRO-MASTER and PRO-MASTER XL is ergonomic in every detail. The workpieces are clamped on the freely movable consoles by means of suction pads and a single-loop vacuum system. The pre-positioned consoles and suction pads can be adjusted via a digital display which is available as an option.
- Up to six machining fields are possible.

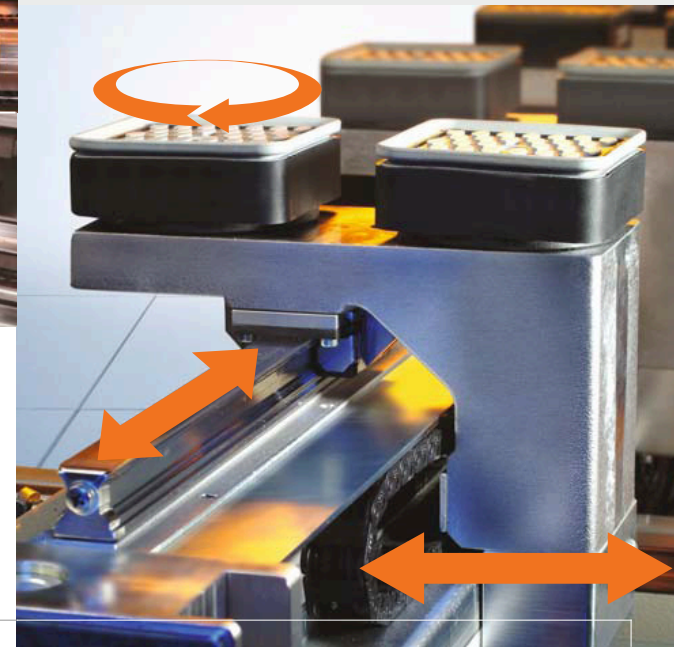

VARIO TABLE

The vario table consists of six consoles, each having three displaceable suction pads. The entire working table can be changed over within a few seconds. Consoles and suction pads are positioned automatically via the control system.

Basic equipment

- Six consoles, positionable in a motor-driven manner via a rack-and-pinion drive on hardened linear guides.
- In each case three suction pad holders per console, in each case one vacuum suction pad with sensing valve, second vacuum suction pad optional.
- Suction pad holders positionable in a motor-driven manner via a rack-and-pinion drive on hardened linear guides.

Options

- Additional consoles and suction pads
- Controlled pneumatic clamps for automatic clamping of window profiles and similar workpieces

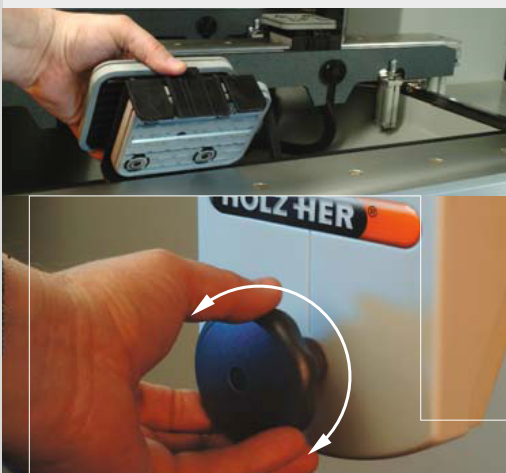

The solution for complicated workpieces

The flat table is the optimal choice for particularly complicated workpieces.

- One of its particular properties is the greater height of the suction pads and thus the large spacing of the workpiece from the table. This creates additional space for machining the underside of the workpiece.
- Freely positionable suction pads on the table surface facilitate the clamping of complicated workpieces made of solid wood and provide a secure hold.

- The flat table is also ideal for working with templates. The high suction power of the double-acting suction pads and their ability to be positioned freely are of great advantage here.



Equipment for high demands

- Two machining fields, each with four solid stop pins (height 95 mm) made from steel for precise positioning even of heavy workpieces. Pins can be lowered pneumatically.
- Twelve double-acting suction pads, surface area: 80 x 80 mm, height: 85 mm and a powerful vacuum pump form part of the basic equipment.
- Special suction pads for narrow parts are available as an option. The program is completed by vacuum suction pads with a grid plate and suction pads with mechanical workpiece clamping.
- Pneumatic loading aids for simple positioning of heavy workpieces are also available (optional).



Perfect for Nested Based Manufacturing

Nested Based Manufacturing (NBM) is a rational method for manufacturing case good parts, fronts and shaped parts. In "nesting", a porous expendable panel (spoilboard), usually MDF, is held on the machine table by suction and the material to be machined is fixed onto it by vacuum. Easy-to-use software

places the workpieces over the blank material and optimises the machining operation. The possible nesting of the workpieces additionally minimises waste. In addition to wood materials, this technology can be used successfully with modern composite materials, metals and plastics on HOLZ-HER machines.

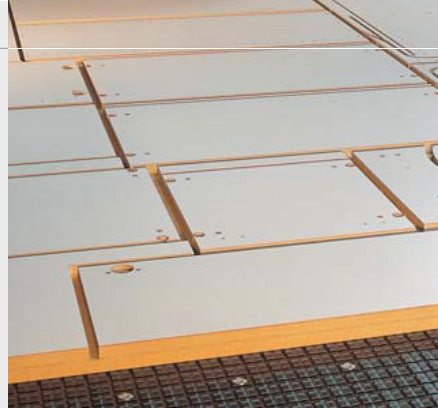

MATRIX TABLE

Developed for maximum productivity

The matrix table offers not just an optimal requirement for the nesting method. Continuous grooves run at a spacing of 50 mm in the X and Y direction over the table and thus achieve an optimised, uniform vacuum. Further properties:

- Continuous machining table with grid pattern. Two machining fields, each with four stops (height 95 mm).
- Insertable vacuum suction pads with a height of 85 mm allow the profiling and end-side machining of workpieces. They can be supplied in various dimensions – 80 x 80 mm, 80 x 40 mm and 80 x 23 mm.
- A loading aid with rollers on all sides can be supplied as an option.



META TABLE

Extremely flexible – two table variants in one machine

The META table is the combination of matrix table and flat table. The name is derived from metamorphosis. It is based on a matrix machine, equipped with retractable stable steel stops (height 105 mm). Conversion from the matrix machine to a flat table machine is achieved by placing a phenol resin panel having a thickness of 10 mm. The vacuum of the matrix table securely holds it by suction. The flat table machine with its flat support is

thus obtained. For each of the two working fields, there are ten vacuum connections for the double-acting suction pads.

- Four aluminium stops which can be freely positioned (matrix table), twelve double-acting suction pads (flat table).
- Optionally two pneumatic loading aids for easy positioning of heavy workpieces.

- A vacuum pump with a power of 250 m³/h ensures the necessary high suction power and thus the secure hold of the workpieces. Vacuum pumps having a power of up to 750 m³/h can be supplied as an option.



MACHINING HEAD

Multifunctional design, optimised for daily use

Drilling, sawing, cutting, grooving – the PRO-MASTER/XL machining head is of multifunctional design and perfectly equipped for the rational machining of simple and complex parts in high production use. The two prismatic guides in the Z direction are hardened and polished and therefore do not allow the slightest deviation.

- The integrated and compact design means that the machining head sets a standard in terms of dynamics, acceleration and positioning accuracy.
- Even in the basic version, the PRO-MASTER/XL offers a wide machining spectrum.
- Drilling unit with 18 spindles which can be called up individually, arranged vertically in an L-shape: power 3 kW, 1000 – 6800 min⁻¹.

- Horizontal drilling unit with two double spindles in the X direction and one double spindle in the Y direction; optional third double spindle in the X direction.
- 6 kW cutter unit with HSK-F 63 in space 1, alternatively 9 or 16 kW cutter unit in space 1.
- Second 6 kW cutter unit with HSK-F 63 in space 2 (optional).
- Sawing unit Ø 120 mm in X direction (optional).
- Sawing unit Ø 200 mm in X direction and Y direction, pivotable (optional).
- Vector axis (C-axis) 0–360° endlessly rotatable for variable use of changeover units (optional).

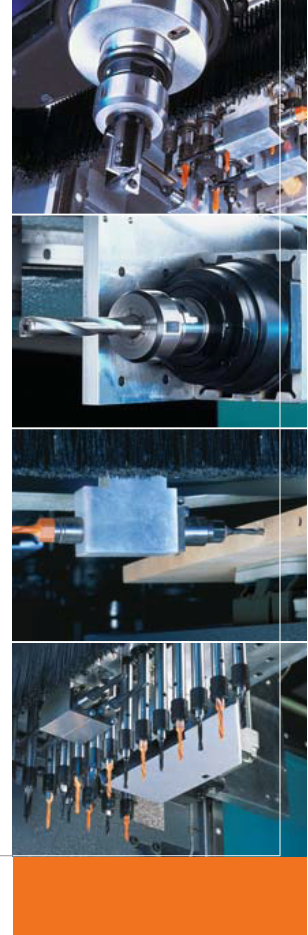
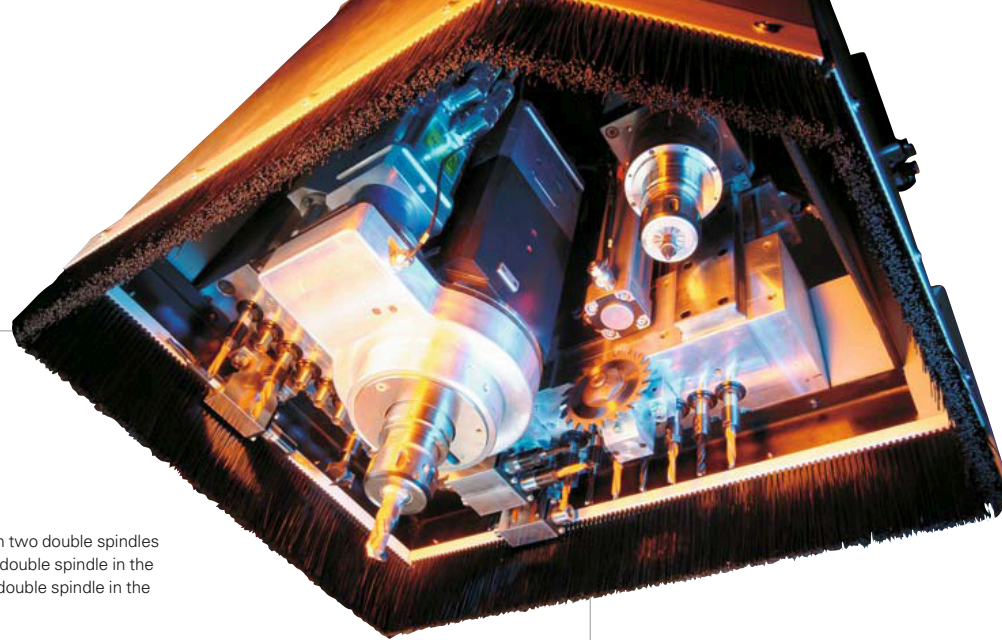

TOOL CHANGER

With a guarantee of high effectiveness

- The travelling tool changer (optional) with 6, 12 or 18 tool spaces ensures short changeover times and high productivity.
- Also as an option there is a pick-up changer with two spaces for large mitre gears and a 14-compartment linear tool changer for the PRO-MASTER and a 16-compartment pick-up installation on the PRO-MASTER XL.

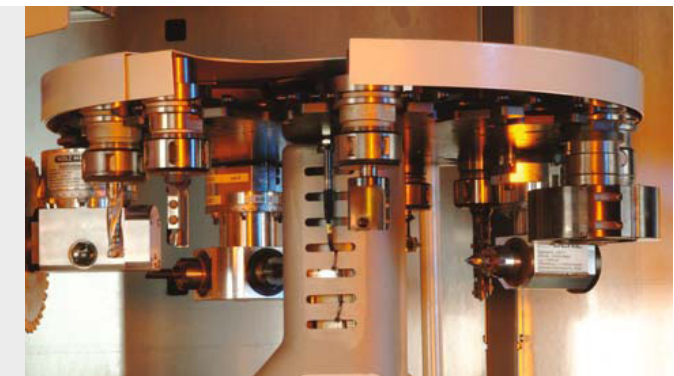



7950

7953

7954

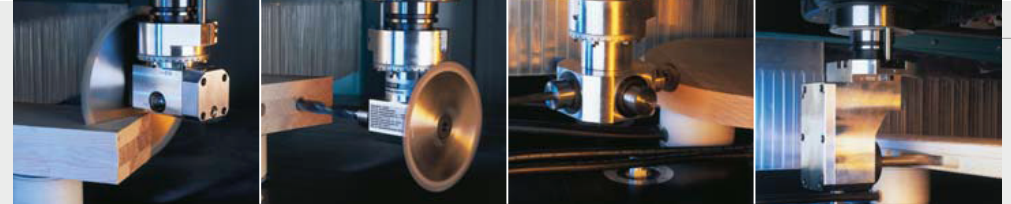

7955

7956

7957

7959

Changeover units – technology which provides inspiration

- **Floating head 7950:** sensing machining. With collet chuck \varnothing 2–16 mm; optional sensing bell with inner diameter 110 or 66.5 mm.
- **Pivoting mitre gear 7953:** drilling, sawing, cutting. Pivoting gear 0–100°; manually adjustable. With saw blade holder \varnothing 180 mm and collet chuck \varnothing 1–16 mm; n (max.) = 15 000 min⁻¹.
- **Mitre gear 7954:** drilling, cutting. Two spindles for collet chuck \varnothing 2–16 mm; 1x left-turning, 1x right-turning; n (max.) = 15 000 min⁻¹.
- **Mitre gear 7955:** sawing. With saw blade holder \varnothing max. 220 mm; n (max.) = 6 750 min⁻¹.
- **Mitre gear 7956:** drilling, sawing, cutting. Two spindles for collet chuck \varnothing 2–16 mm and saw blade holder \varnothing max. 180 mm; n (max.) = 15 000 min⁻¹.
- **Mitre gear 7957:** drilling. Four spindles for collet chuck \varnothing 1–16 mm; n (max.) = 10 000 min⁻¹.
- **Angle head/lock setting cutter unit 7959:** One output for tool shaft \varnothing = 16 mm; n (max.) = 12 000 min⁻¹.

CHANGEOVER UNITS

Solutions for each field of use



A wide choice of changeover units makes the machining of even complex workpieces even faster, more rational and easier. Quality and profitability are decisive details. The large number of modern materials and different design variants require competent and reliable solutions. To this end, the PRO-MASTER series offers flexible answers for a wide range of applications.

C - AXIS

Continious rotation

The optional C-axis, available on the HOLZ-HER machining centers PRO-MASTER and PRO-MASTER XL are endless rotatable. This widens the spectrum for demanding machining programs.

- As a genuine, fully interpolated additional axis, it can be rotated in a flowing manner in all directions during the machining operation.
- Smooth adjustability and endless rotation through 360° increase the flexibility.
- The C-axis can thus be positioned on the shortest, direct route.
- A pneumatic option additionally permits simultaneous blowing during the cutting process.



CONTROL SYSTEM

Simple, clear, convenient

The Siemens SINUMERIK compact control system guarantees outstanding digital precision. At the same time, the graphic user interface CAMPUS allows convenient and clear use of all machine functions.

- Operating programs can easily and quickly be created directly on the machine or on the supplied office version of the software package.
- "Easy snaps", adjustable parameters and well-conceived macros additionally simplify and speed up the program control.
- An open software architecture allows non-complicated incorporation of existing data and connection to a wide range of branch, design and CAD/CAM software.

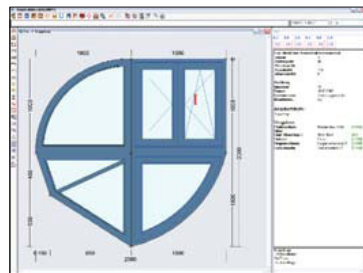
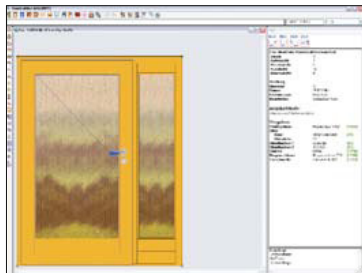
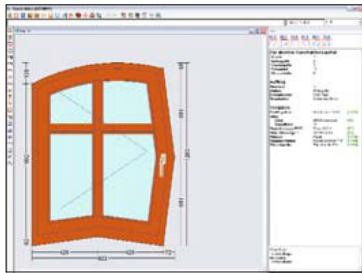
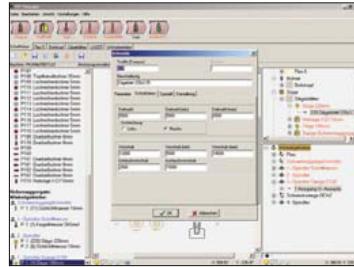

DATA COMBINING

Networking – more than just a word

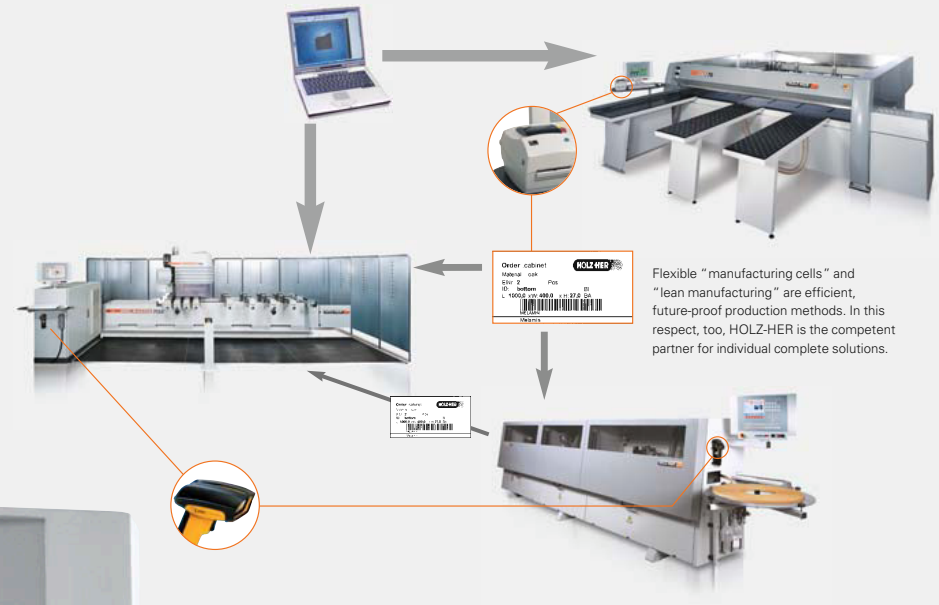

Flexible "manufacturing cells" and "lean manufacturing" are efficient, future-proof production methods. In this respect, too, HOLZ-HER is the competent partner for individual complete solutions.

Clear control

- The universally structured graphic user interface is of intuitive and clear design. It includes numerous functions for effectively and comprehensively using the PRO-MASTER/XL.
- In addition to variable programming, 3D views and simulations, NC Hops Editor offers full Z-axis interpolation and a text editor.
- Campus aCADemy is a full-value, high-performance CAD/CAM software package with multiple import possibilities.
- WorkCenter shows the occupancy of the machine table. Tools, drilling heads and routes are automatically optimised over the workpiece as a whole and the machining times are calculated.
- The tool manager MT Manager allows clear, graphic set-up by means of "drag & drop".

Table variants for all requirements

The PRO-MASTER/XL with its different workpiece supports is provided in order to improve working procedures for various requirements. With its generous dimensions, the PRO-MASTER is designed for the individual machining of even extreme jobs. The larger displacement travels of the XL version in Y and Z open up new machining dimensions.

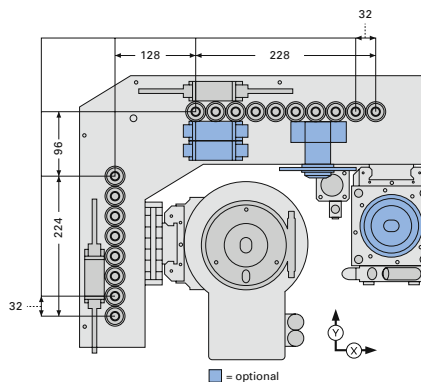

The machining head

Drilling, sawing, cutting, grooving: the machining head offers a wide performance spectrum. The integrated and compact design means that it sets a standard in terms of dynamics, acceleration and positioning accuracy.

PRO-MASTER console table

All dimensions given in mm

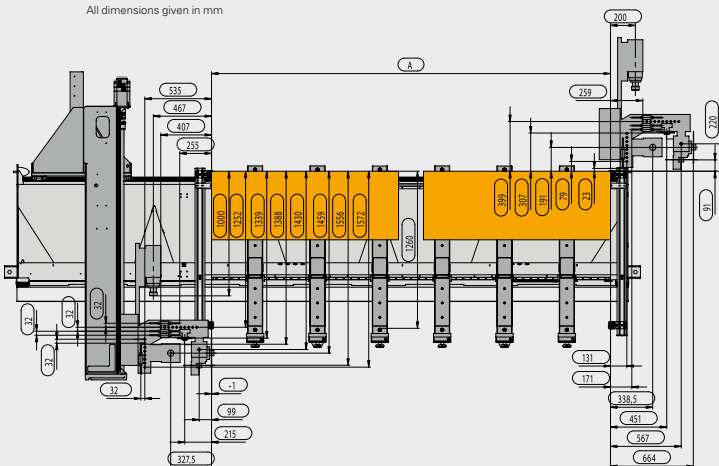

Z-axis

All dimensions given in mm

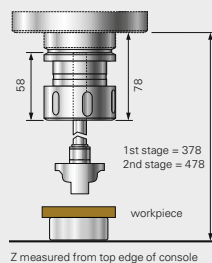

All dimensions given in mm	A
PRO-MASTER 7123 K	3200
	4100
	5000
	5900

PRO-MASTER flat table

All dimensions given in mm

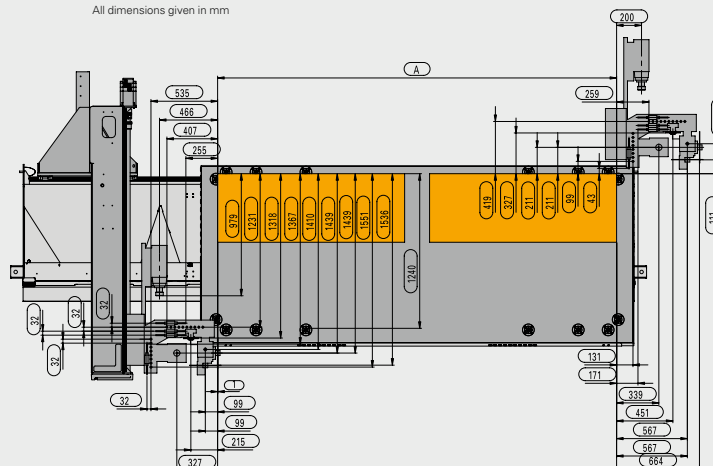

Z-axis

All dimensions given in mm

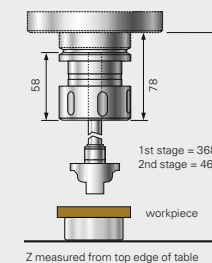

All dimensions given in mm	A
PRO-MASTER 7123 F	3200
	4100
	5000

PRO-MASTER XL console table

All dimensions given in mm

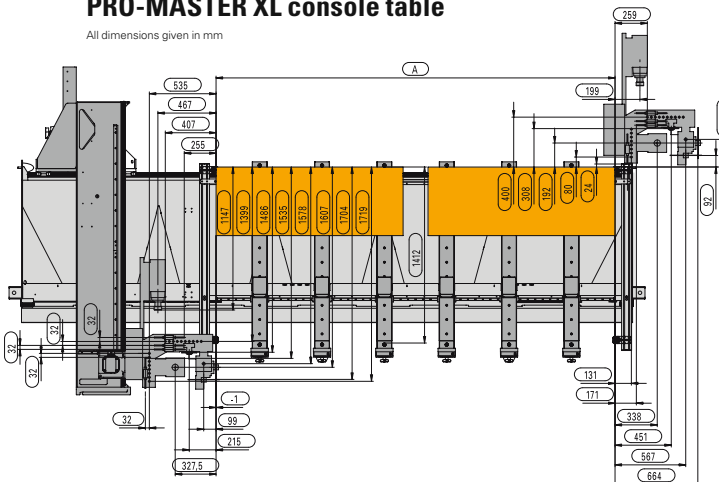

Z-axis

All dimensions given in mm

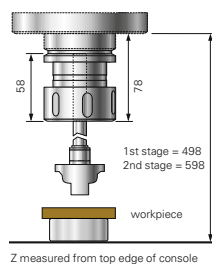

All dimensions given in mm	A
PRO-MASTER 7223 K	3200
	4100
	5000
	5900

PRO-MASTER XL flat table

All dimensions given in mm

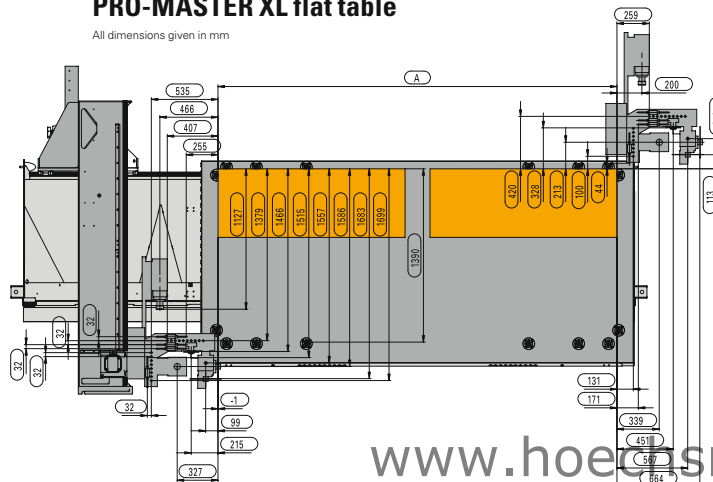

Z-axis

All dimensions given in mm

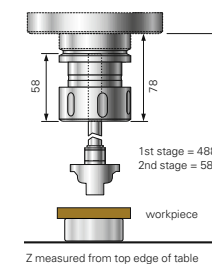

All dimensions given in mm	A
PRO-MASTER 7223 F	3200
	4100
	5000

Technical data

Machine dimensions	PRO-MASTER 7123	PRO-MASTER XL 7223
Weight (kg)	4300	4300
	4450	4450
Antriebe Grundmaschine		
Max. displacement speed, X-axis (m/min ft./min)	100	328.08
Max. displacement speed, Y-axis (m/min ft./min)	100	328.08
Max. displacement speed, Z-axis (m/min ft./min)	25	82.02
Max. displacement speed C-axis (min ⁻¹)	60	60
Motor power, cutter unit type 7930 (kW)	6.0	6.0
Rotational speed, cutter unit type 7930 (min ⁻¹)	1000 – 18000	1000 – 18000
Motor power, cutter unit type 7933 (Option) (kW)	11.0	11.0
Rotational speed, cutter unit type 7933 (Option) (min ⁻¹)	1000 – 24000	1000 – 24000
Motor power, cutter unit type 7935 (Option) (kW)	16.0	16.0
Rotational speed, cutter unit type 7935 (Option) (min ⁻¹)	1000 – 24000	1000 – 24000
Motor power, drilling unit type 7964 (kW)	3.0	3.0
Rotational speed, drilling unit type 7964 (min ⁻¹)	1000 – 6800	1000 – 6800
Electrical system		
Connection voltage (Volt)	3 x 400	3 x 400
Mains frequency (Hz)	50/60	50/60
Power (depending on equipment) (kW)	22	22
Compressed air		
Operating pressure (bar)	6.0	6.0
Permissible limit pressure (bar)	8.0	8.0
Compressed air requirement (l/min)	300	300
Suction		
Suction power (m ³ /h)	5300	5300
Static underpressure (Pa)	2500 – 3000	2500 – 3000
Connector Ø (mm inch)	290	9.84
Suction speed at the connector (m/s ft./s)	30	98.43

The technical data given are guidelines. We reserve the right to make changes, since our HOLZHER woodworking machines are constantly being developed. The images are therefore also not binding. The machines shown in some cases also contain special equipment that does not come as standard. Please ask your HOLZHER dealer for details of the equipment included. We reserve the right to make changes in terms of design and equipment.

Printed: 3 February 2008

Your authorised **HOLZ-HER Special Machines dealer**

REICH
Spezialmaschinen GmbH
D-72608 Nürtingen

Tel.: +49 (0) 70 22 702-0
Fax: +49 (0) 70 22 702-101
www.holzher.de

HOLZHER
Special Machines

www.hoechsmann.com