

Processing centres BMG 500



Be on the safe side with HOMAG

An investment in a new machine or plant should not be an experiment. Opt for a competent, experienced and reliable partner you can trust – opt for HOMAG.

- Competence and experience gathered over almost 50 years
- Production of over 1,000 processing centres a year throughout the HOMAG Group
- A motivated workforce of over 4,000 working to produce the legendary standard of HOMAG quality in 12 locations

Affordable high-technology for woodworking shops and industrial producers:

- BMG 500 gantry series processing centres offer an extensive range of equipment possibilities for industrial multiple-shift operation
- The unique basic machine construction made of the solid composite material SORB TECH guarantees optimum processing quality through vibration damping and extreme durability
- Different process technologies such as sawing, trimming, edge banding, hardware mounting, measurement processes and 3D processing can all be combined to ensure a truly future-proof investment

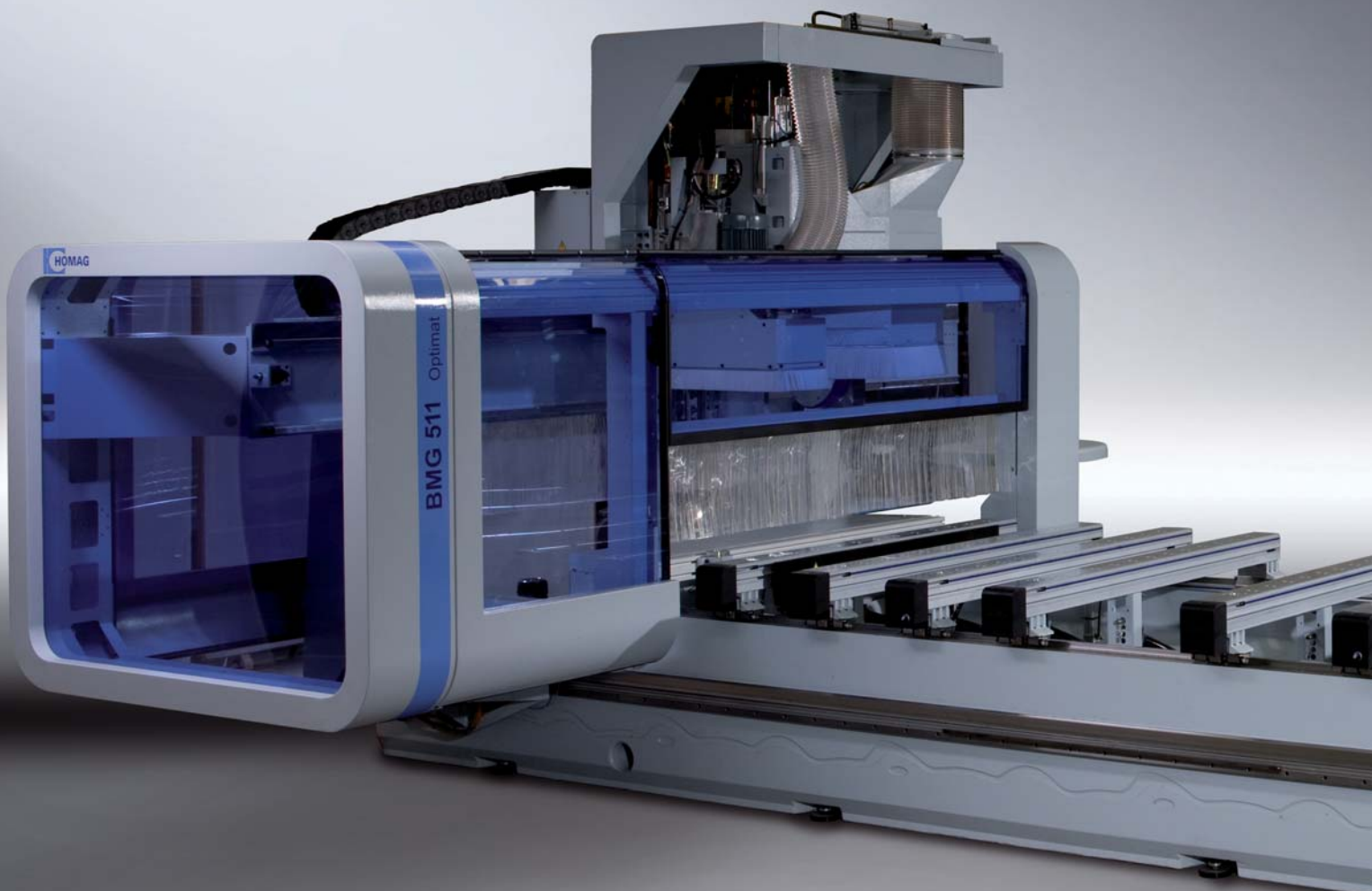



Precise shift cuts – extreme fitting accuracy from the word go, even with extreme material thicknesses

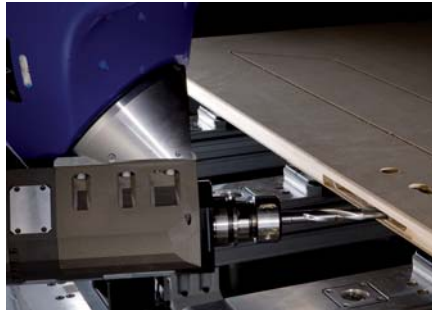

DRIVE5C+ five-axis spindle for fewer units and greater flexibility in the design of your products



Contents

| | |
|----|--|
| 06 | BMG 500 – economy from the factory floor |
| 10 | Furniture production |
| 12 | Home and vehicle interior fittings |
| 14 | Staircase production |
| 16 | Window production |
| 17 | Door production |
| 18 | Console tables |
| 20 | Automatic positioning tables |
| 22 | Matrix tables |
| 26 | Processing units |
| 30 | Software/control |
| 32 | LifeCycle cost |
| 34 | Technical data BMG 500 |

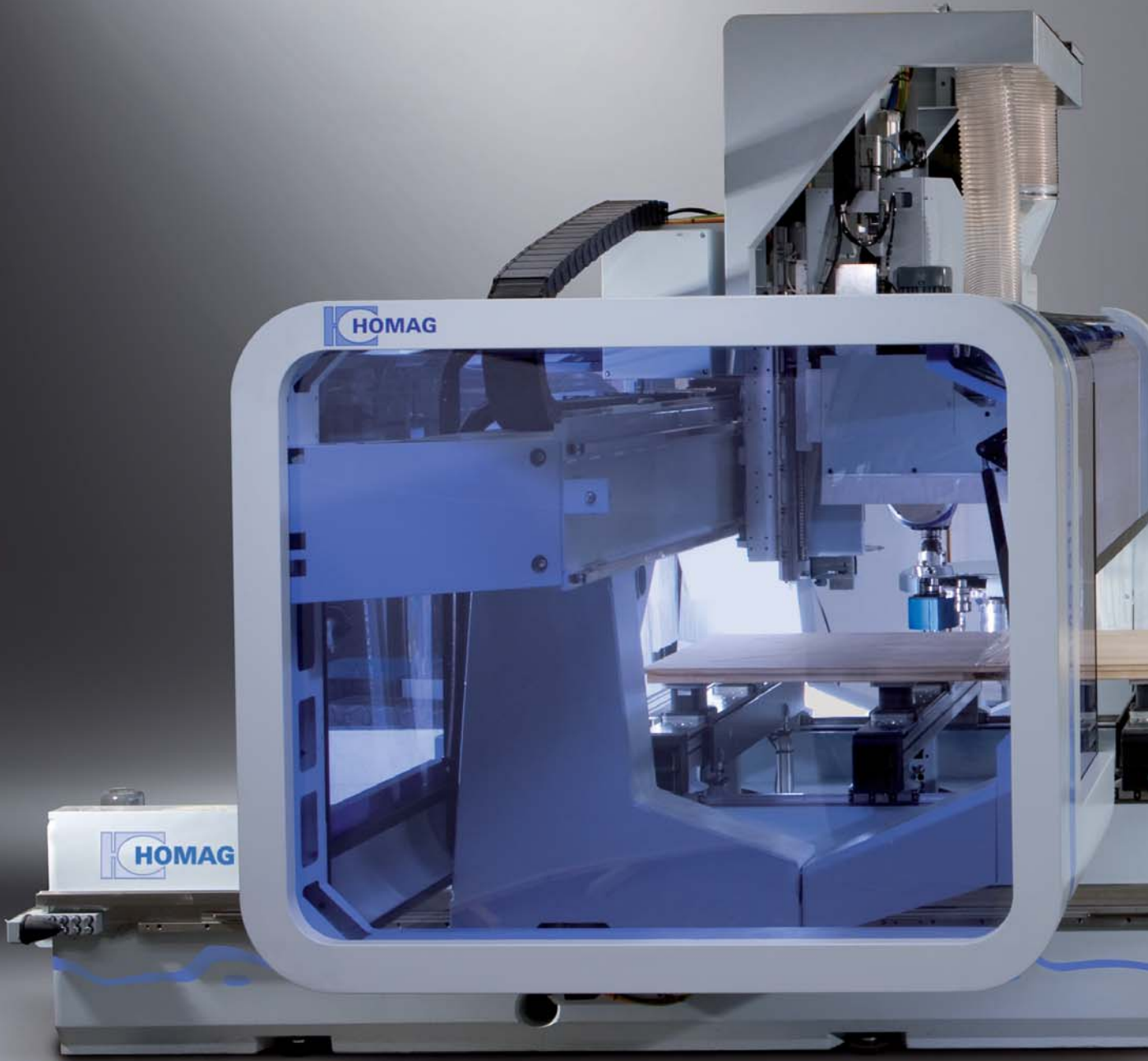

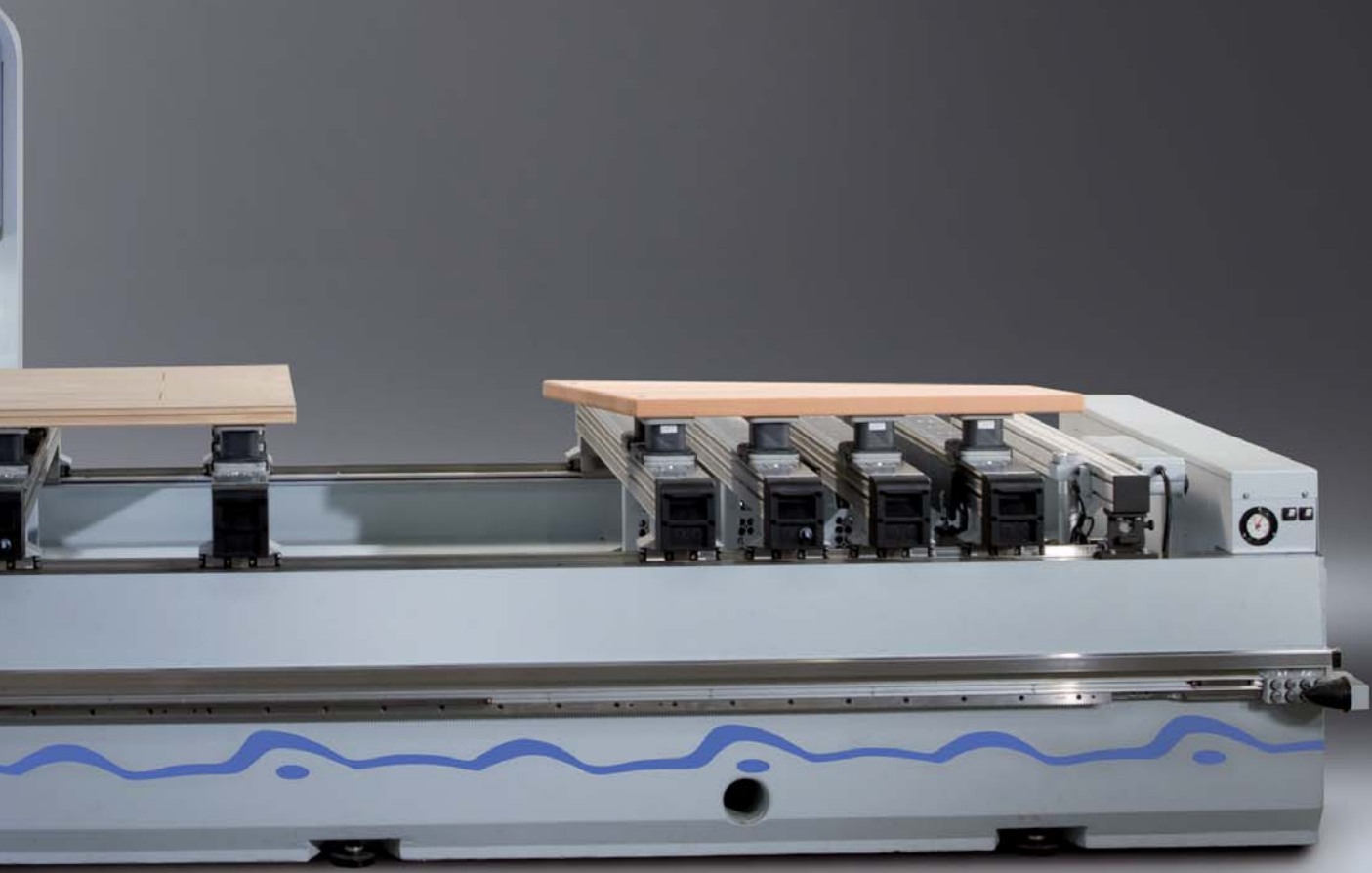

BMG 500 – Economy from the factory floor

Deciding in favour of a HOMAG machine means investing in a highly efficient processing centre with the capability to fulfil wide-ranging different manufacturing requirements. Each machine is a complete system guaranteeing maximum output and efficiency every time – no matter how individual your production requirements are.

Data link

CAD/CAM

Data transfer from CAD/CAM systems for fast program generation

ERP systems

Direct link to ERP systems for the transmission of job lists

Energy efficiency

Cost reduction by optimizing energy consumption through:

- The use of a water ring vacuum pump for spindle cooling
- Intelligent standby operation
- Efficient dust extraction flap control in conjunction with two separate Z axes per processing unit

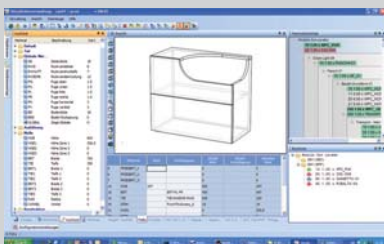
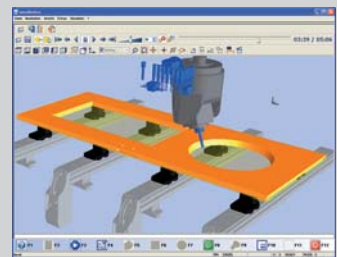

Process optimization

Monitoring

Feedback of machine and status using MDA (machine data acquisition)

Simulation

Program sequence testing for precise production time determination and production planning, including machine component and clamp collision analyses

Protecting the environment and improving economy

A heavy-duty machine bed made of the new vibration-absorbing material SORB TECH helps save around 60% primary energy and enhances processing quality.

- Optimum surface quality
- Extension of tool life by up to 20 %



Outstanding surface quality due to vibration-damping machine beds

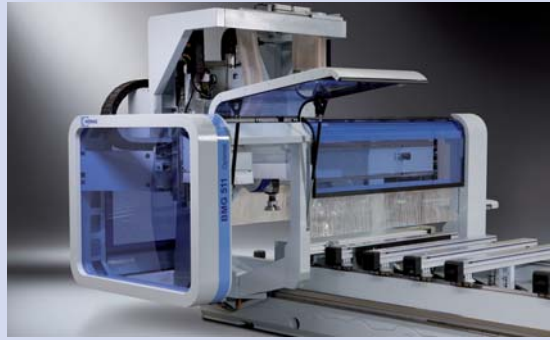

Safe and functional

The coupled-motion partial enclosure offers additional protection for machine operators while affording a clear view of processing operations. A lateral flap permits barrier-free access to the processing units.

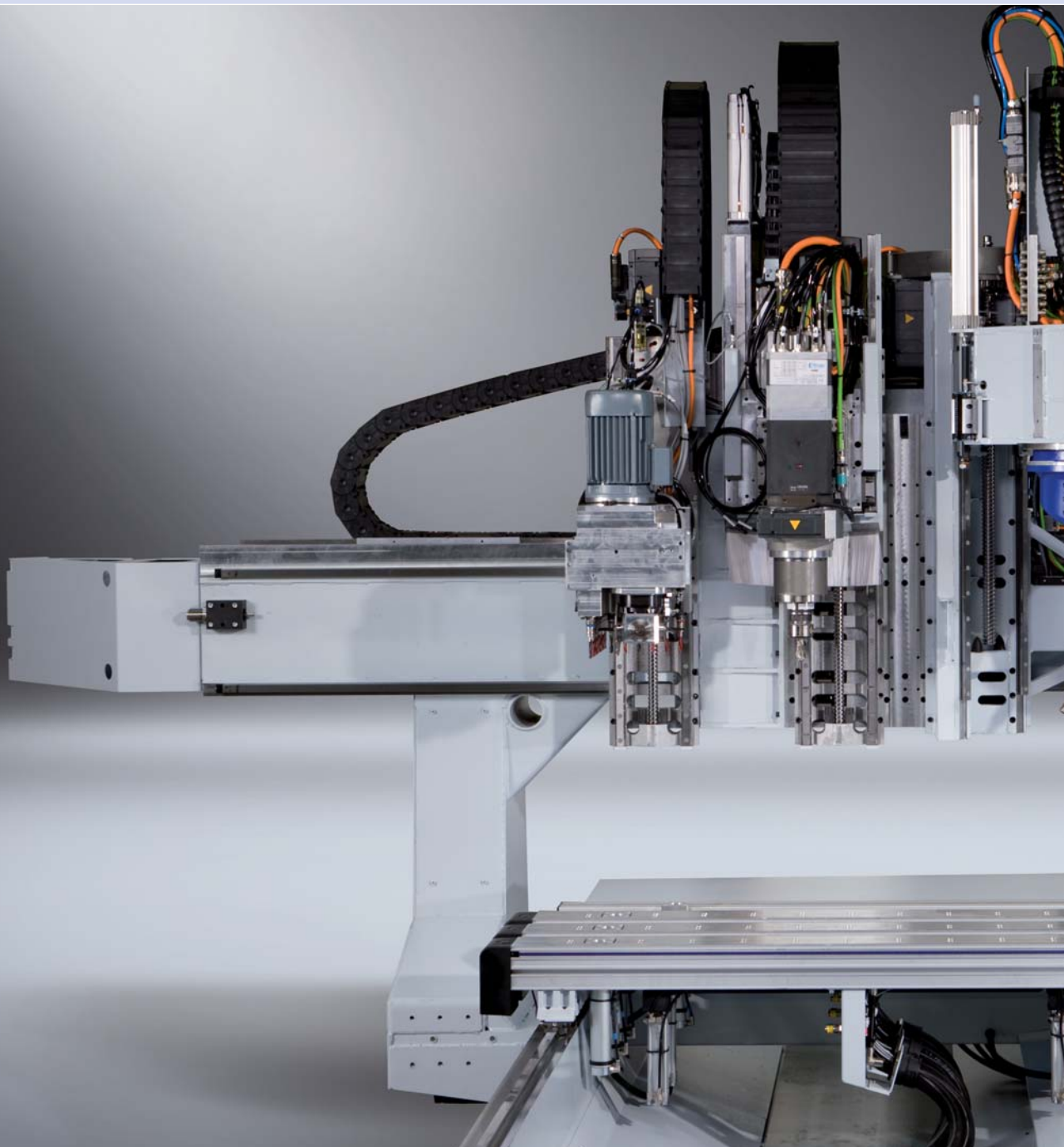

Scaleable output

Up to three processing units can be individually mounted for fast tool exchange, for instance two trimming spindles and one drilling head in conjunction with two tool changers.

LifeCycle cost

Modification

Increased machine life cycle due to capacity for retrofitting units, clamps or automatic workpiece handling for adjustment to new products

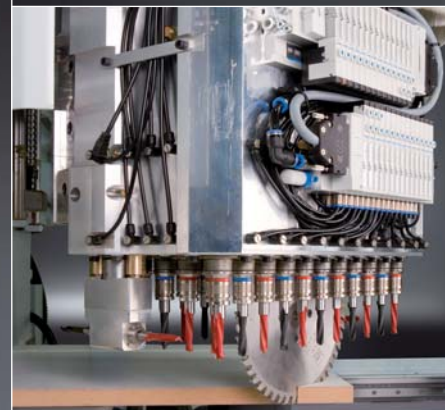
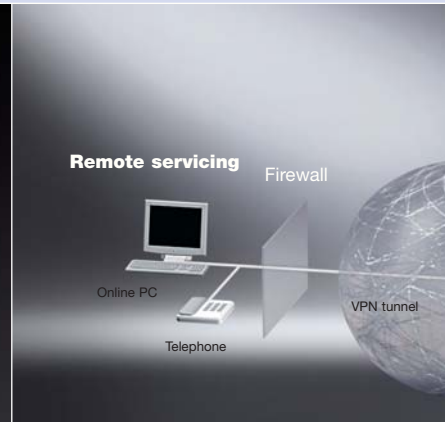
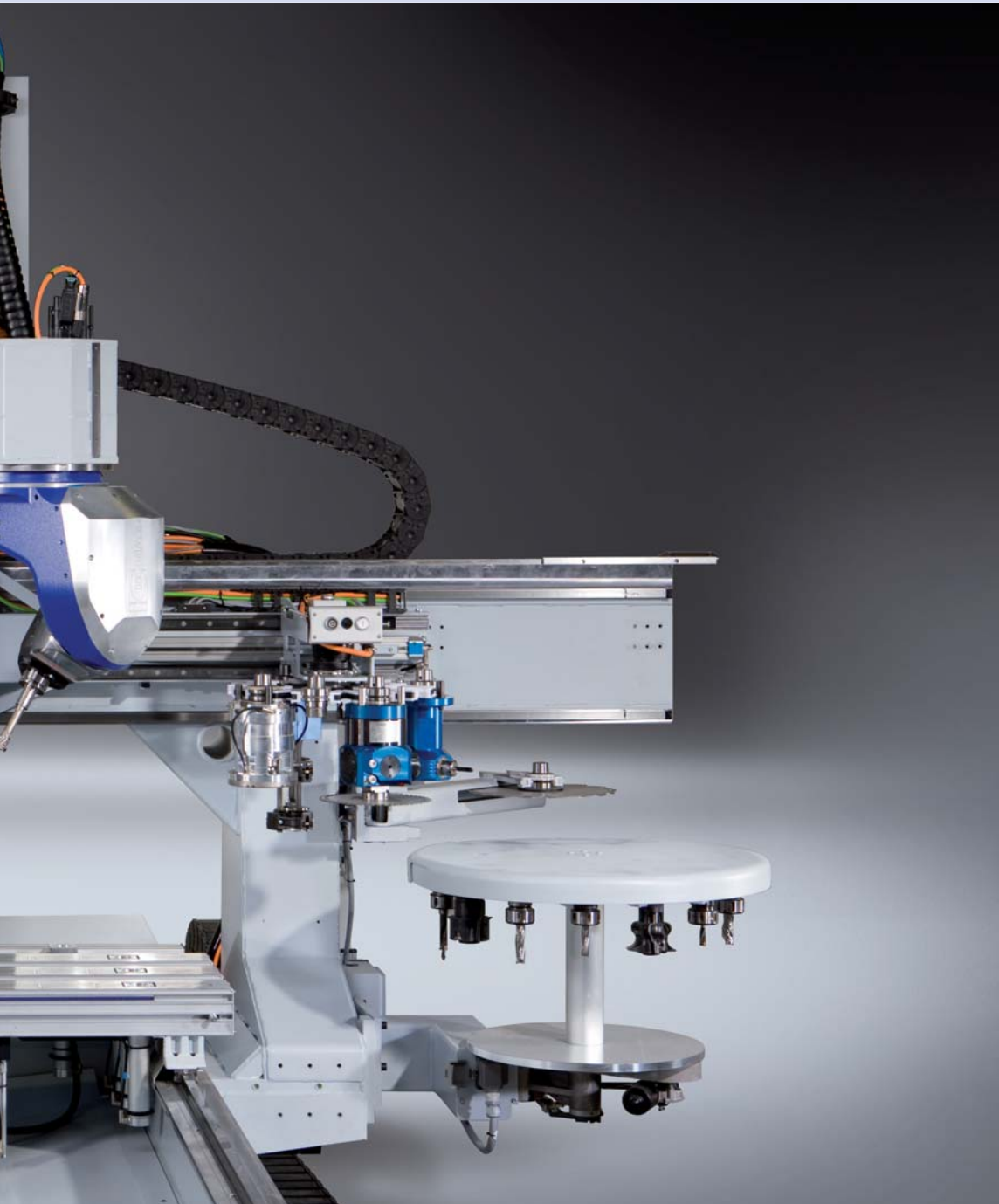

Process integration

Integrating several work processes into one eliminates handling costs and transportation damage as well as enhancing precision.

All in a single work step:

- Drilling, trimming, sawing
- High-precision electronically traced processing operations
- 5-axis shaped component processing

<Different table systems for flexible, safe fixture of different workpieces.
Depending on the workpiece geometries and surface properties, fixture is optionally possible using vacuum, pneumatic and mechanical clamps.

Workpiece fixture

TeleServiceNet

Teleservice round the clock to reduce standstill times and prevent costly service callouts

Inspection and maintenance

Preventive machine checks and exchange of wearing parts to prevent machine failure

Console tables

The console table is the flexible solution offering optimum waste piece and chip disposal

Automatic positioning console table (AP table)

The AP table is our high-end system for production cells and batch size one

Matrix table

The matrix table is the classical variant for nesting, when processing small parts or using templates

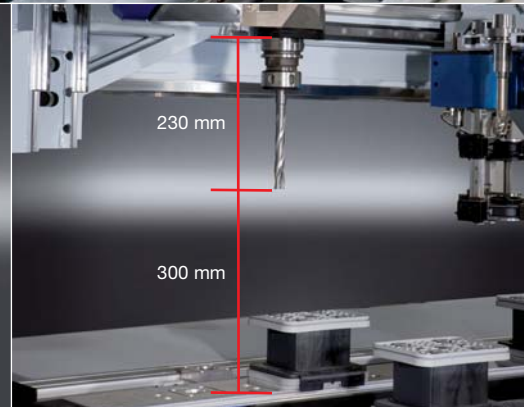
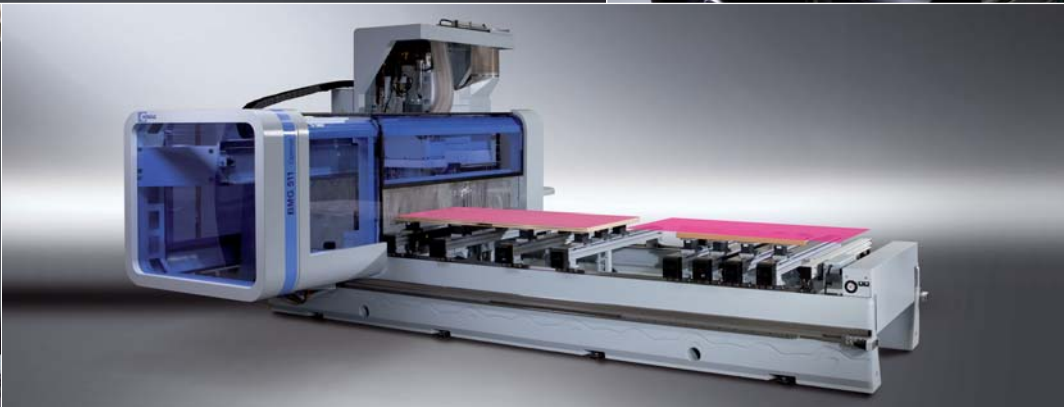
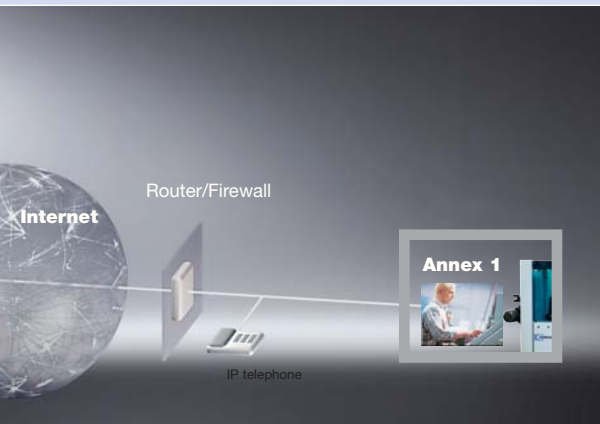

Processing dimensions

Alternating processing

Two processing fields of max. 2,375 / 1,550 mm allow resetting and loading processes to be performed simultaneously with processing operations

Block processing

Cubic workpieces of up to 300 mm in height can be processed by the large 600 mm axes, even when working with the maximum workpiece length of 230 mm (measured from the HSK support)

Furniture production

Flexibility is paramount to the economical production of furniture components. HOMAG machines are capable of performing several different furniture component processing operations and are also able to cope with wide-ranging workpiece geometries and quantities.



Traced trimming of curved furniture fronts with DRIVE5C+ five-axis spindle

Series BMG 500 processing centres provide the assurance of outstanding quality and efficiency improvements through:

- Integration of different work steps such as sizing, edging and drilling
- Automatic part handling
- Optimized process parameters per workpiece (feed rates, rotational speeds, tools etc.)
- Flexible adjustment of your products to market demand “without” machine restrictions



5-axis spindle

- Precise processing at any angle without tolerances caused by additional units
- “No” restrictions to the creativity of your product design
- Functional upgrading through scope for a large number of different units, e.g. for sanding or traced trimming operations

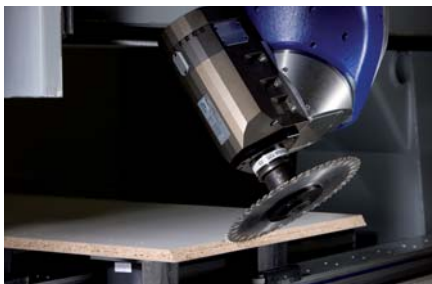

Drilling units

- Different drilling heads with variable speeds of up to 7,500 rpm and patented quick-change system for drill bit changeover without the use of tools
- The Multi Processing Unit (MPU) is capable of stepless 360° swivel action, allowing both the saw and all 20 vertical and 10 horizontal spindles to be deployed at any optional angle
- A trimming spindle attachment saves tool changes and enhances productivity

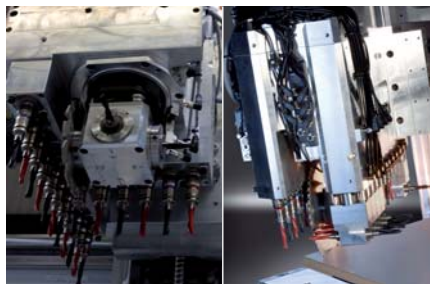

Console tables

- Console tables offer optimum facility for waste piece disposal
- Automatic console and clamp positioning (AP table) provides the ideal addition for automatic feed / small batch sizes



woodDesign

- woodDesign is a modern 3D design tool for the interactive design of carcase furniture. It allows complete workpiece programs to be generated in just seconds



sensoflex tracing system

- Perfect workpiece quality – the traced spindle compensates any unevenness and unwanted tolerances
- Complete flexibility through the use of tracing for different tools
- Functional upgrade through the use of wide-ranging different units (the tracing ring automatically travels upwards)
- Sensitive tracing pressure adjustment facility for sensitive materials

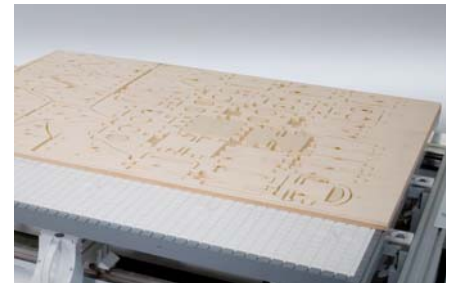

Adapter panel for small parts

- Highly flexible clamping systems offer secure fixture even when working with filigree workpieces. The matrix adapter panel even permits shaped components to be „cut to size“ with optimized cutting waste on a console table machine using the nesting process

Home and vehicle interior fittings

Individual production and precise processing of wide-ranging different materials are essential when it comes to the efficient processing of interior fittings. Not only does 5-axis technology permit a large variety of processing operations without additional units, it also opens up scope for creative product design, including features such as curved panelling.

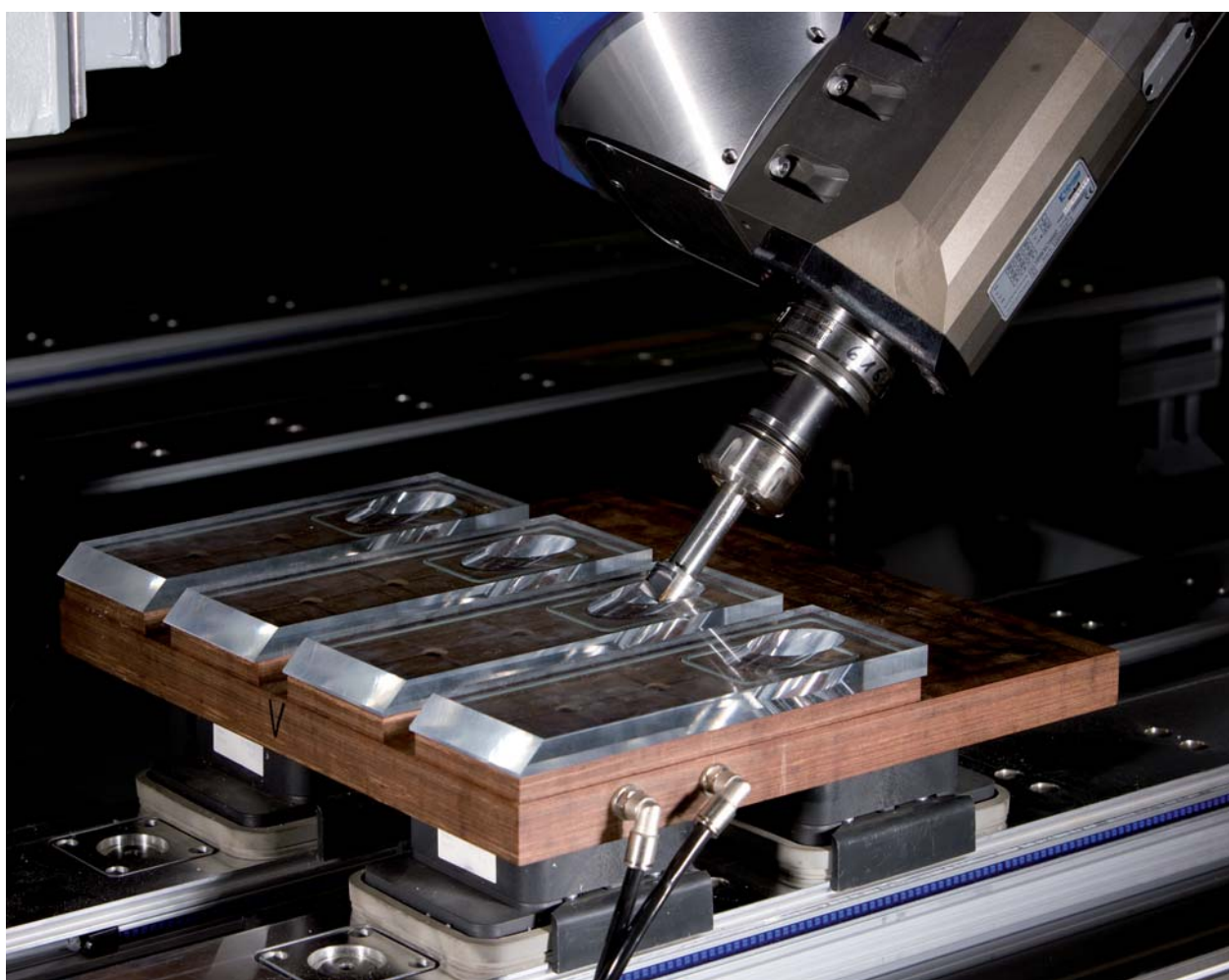

Top-quality interior fittings are characterized by individual design and an extensive choice of different materials. The resulting demands made on processing centres, such as 5-axis technology for curved fronts or trimming tool cooling systems for acrylic processing are all provided by HOMAG processing centres – effectively removing future barriers to

- the use of wide-ranging different materials
- creative design of interior fittings for your customers
- precision fitting and reproduction accuracy even for the most complex shapes
- surface designs on materials such as engraving effects, acoustic grooves or boreholes
- fast, reliable programming and production by adopting CAD/CAM data



Minimum quantity lubrication for aluminium

- The patented unit interface with facility for pneumatic and fluid transmission to exchangeable units allows cooling and lubrication as well as the reliable removal of chips



Five-axis technology

- The DRIVE5+ five-axis spindle offers whole new scope for design, and a wide range of available future-proofing options for the ultimate investment security

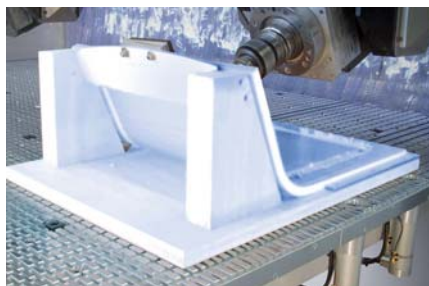

High-gloss trimming

- Using variable spindle speeds of 100 – 24,000 rpm in conjunction with monocrystalline diamond cutters and the highly rigid machine construction, high-gloss trimming operations on acrylic are possible achieving a remarkable standard of quality

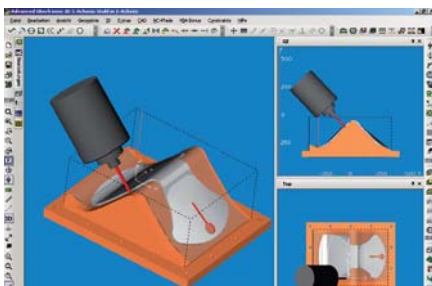

CAD/CAM systems

- Data links are available to all commonly used CAD/CAM system manufacturers, allowing “simple” program generation of even the most complex 3D shaped components with a high degree of reliability and minimal expense

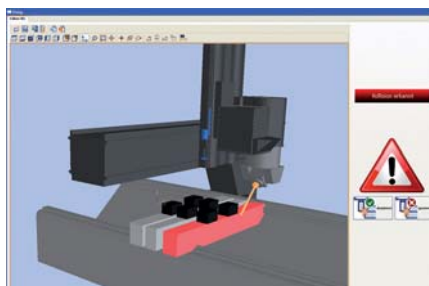

collisionControl

- With the latest control and programming generation from HOMAG, collision monitoring is now also possible during 5-axis processing, offering optimum protection for tools and workpieces, the machine and the operator

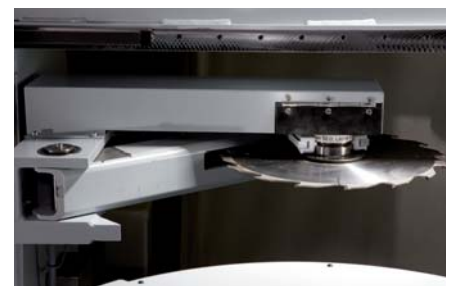

Pick-up station for large saw blades

- Large tools and units can be positioned using the standard tool changer. An additional pick-up station permits the use of a 350 mm saw blade for dividing cuts in workpieces up to 110 mm thick

Staircase production

Free design and automatic production of every conceivable type of staircase. HOMAG processing centres with 5-axis technology make for a drastic reduction of production times. Technically speaking, they offer practically unlimited scope.

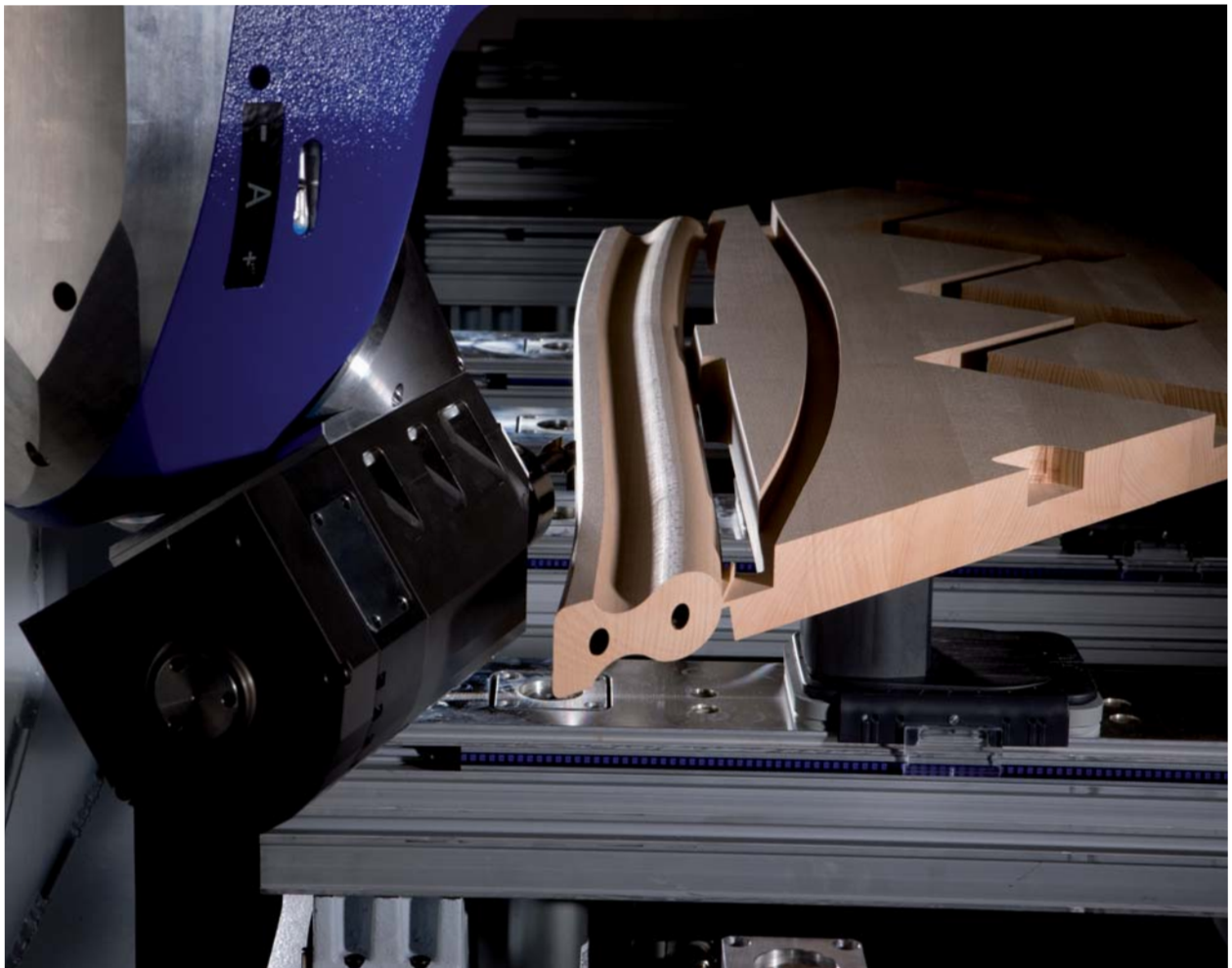

Holes for piling at narrow angles

Depending on the staircase rise, processing operations can be executed by the efficient, compact DRIVE5C+ trimming spindle at an approach angle of 20°

Your processing centre can be configured to be as individual as the solid wood types you process. Depending on your production sequence, we offer ideal solutions for:

- Staircase tread production including dividing the gluelam panels using the nesting process
- Profiling curved handrail elements using 5-axis technology
- Staircase stringer production complete with all the necessary recesses and trimming operations, even with complex geometries
- Automatic workpiece handling
- Adoption of data from all trade-specific software packages



5-axis technology

- Trimming spindles with up to 5 axes and in different performance categories offer high hogging output and outstanding processing results.

Performance pack

- The performance pack with the patented pneumatic interface permits the use of traced units, for example for precise rounding of staircase treads independently of thickness tolerances
- Spindle outputs are further increased by the addition of a cooling unit.

DRIVE5C+ trimming spindle

Compact design, high performance

- The compact design of the spindle permits workpieces to be processed from below with larger tool diameters.

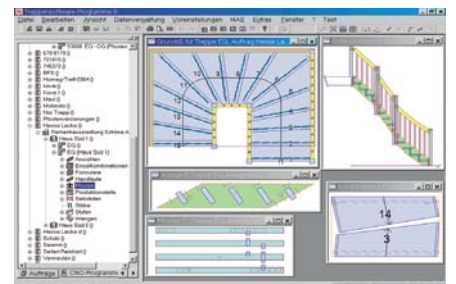
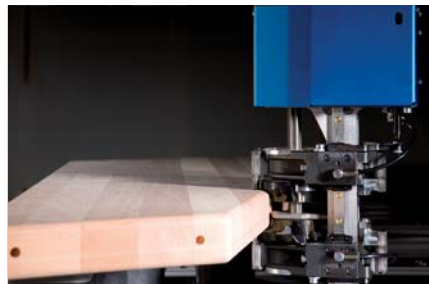

Manual and automatic positioning console tables

- Console tables with integrated vacuum and additional pneumatic systems permit optimum waste piece and chip disposal in conjunction with flexible, reliable fixture of workpieces
- The AP table for automatic positioning of clamping elements offers scope for traversing workpieces, for instance after the separation of two staircase treads, for further processing operations

Separating cuts with optimum extraction

- In conjunction with a saw blade diameter of 350 mm separating cuts are possible through workpiece thicknesses of 110 mm. The compact spindle design permits the dust extraction hood to be ideally height controlled even when performing this processing operation.

Staircase software

- Data links to all commonly used trade-specific software packages permit fast, automatic provision of machine programs

Window production

It is impossible nowadays to imagine window production without the benefits of modern CNC processing. As the market leader, HOMAG offers highly efficient complete solutions which allow up to five different work steps to be performed on a single processing centre.

Ever more stringent energy saving, noise insulation and safety requirements have culminated in a wide variety of different window systems. HOMAG offers a selection of highly flexible processing centres designed to address the demands of present and also future window design characteristics, such as:

- Greater profile depths of up to 150 mm for increased thermal insulating glass thicknesses and

- improved insulation performance
- Different materials such as insulating core panels in PU and linings made of purenit or aluminium
- Conservatory and facade constructions in multiplex or other materials
- Increasing integration of functional assemblies such as ventilators, alarm system contacts etc.



With a maximum saw blade diameter of 350 mm, even precise shift cuts for conservatory production can be executed without problems.

Door production

From the standard door to the custom-produced design, from series manufacture through to bespoke batch one production: Our machines and plants are designed to address widely differing requirements and adjust quickly and efficiently to the demands of each application.

No matter how complex the door leaf structure or rebate geometry of your top-quality door elements are: HOMAG offers its BMG 500 processing centres with several processing units for reduced tool changing and enhanced productivity. All processing steps are performed to a high degree of precision:

- Profiling and grooving, for example for door seals
- Trimming for glazing panels
- Lock and hinge processing operations
- Decorative grooves with precise surface tracing
- Frame assembly hole trimming and drilling operations

High-speed tool change

- The installation of two trimming spindles permits the reduction of chip-to-chip times and improved productivity. While one spindle is trimming, the second one is being fitted with the tool required for the next processing operation



Door leaf processing

- Both window components and door leaves can be completely processed on a processing centre



Tool change systems

- Large tool storage systems with up to 28 slots permit the production of different window systems with profile depths of up to 120 mm without manual tool changes

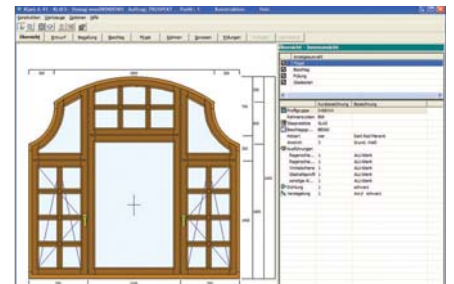
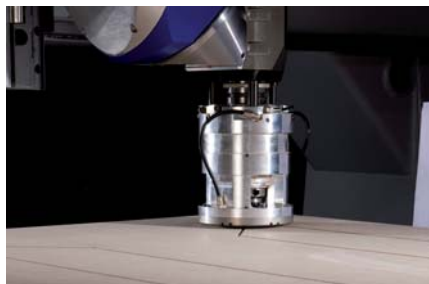

powerClamp

- Extreme hogging forces during longitudinal profiling call not only for sufficient spindle output but also clamping systems with high retaining forces. The **powerClamp** system provides a highly precise corner connection for window production, ensuring economical single part production without the need to rebate around the sash

Traced trimming operations

- Decorative grooves can be trimmed to a high standard of precision through the use of traced units, allowing compensation of workpiece thickness tolerances for top quality results.

woodWindows

- The software package for window element design inclusive of data transmission to the processing centre



The Maxi-Flex clamping system creates a cohesive platform for optional clamp positioning.

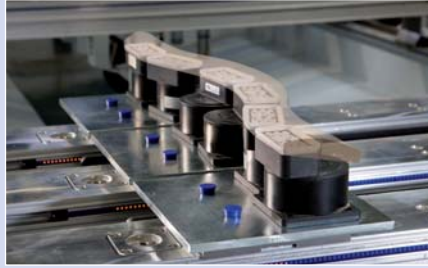

Even narrow, curved parts can be safely clamped using the Maxi-Flex clamping system



LED system – both the fastest and safest positioning system for consoles and clamping elements (patented)

Stop pin position within the machine bed, waste peaces and chips drop inside the machine bed for automatic waste disposal



The right table for every assignment

HOMAG offers a range of innovative, practically oriented table variants for wide-ranging different requirements, making the precise fixture of workpieces simplicity itself. Extreme processing precision and perfect product quality are the result.



Push-off rails with two pneumatic cylinders simplify the positioning of heavy workpieces



Manual clamping fixture **powerClamp** for straight and curved parts. Ideal for window construction



More information is provided in our processing unit and clamping element catalogue

Fast, neat and convenient - the console table

- Fast console adjustment in a single movement
- Variable number of vacuum clamps due to hoseless vacuum system
- Highly rigid consoles for precise part fixture and optimum processing precision
- No jamming when traversing consoles due to four linear guide carriages per console
- Generous clearance for waste pieces under the consoles
- Stop pin position inside the machine bed, waste pieces and chips drop inside the waste piece disposal area

Greater output with flexible clamping systems

The exclusive vacuum clamp platform with patented double sealing lip for console clamping technology:

- For stepless displacement of hoseless vacuum clamps along the console
- Independence from suction points in the console
- Dual circuit vacuum system prevents unwanted displacement of vacuum clamps when positioning parts

Saves time and enhances flexibility: The AP automatic positioning table

AP – automatic positioning – provides the key to greater convenience, faster set-up and optimized processing steps. The automatic positioning of clamps permits operations such as moving workpieces apart after a separating cut.

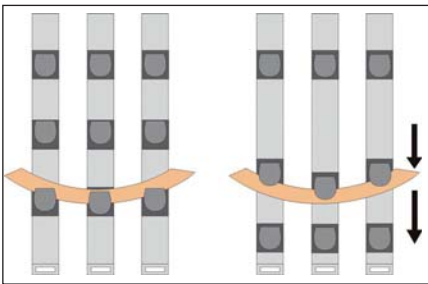

Automatic reclamping of individual parts for double-sided processing

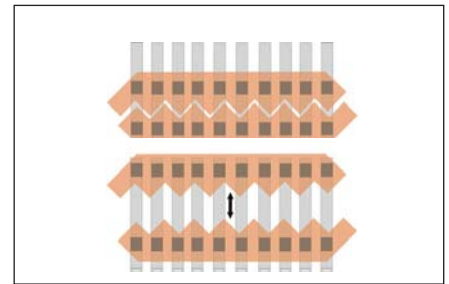
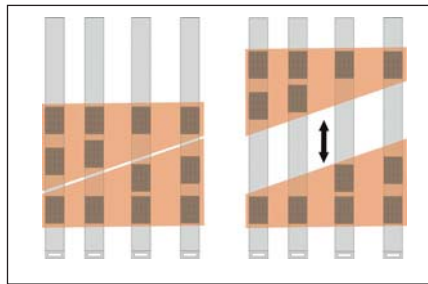

More information is provided in our processing unit and clamping element catalogue

Less setting up, more output –the AP table

- Fully automatic table set-up, including precisely positioned clamping elements
- Facility for resetting the work table during workpiece changeover
- Substantially reduced downtimes
- High output and efficiency even for batch size 1
- Facility for expansion to create a low-manned production cell
- Use of different types of vacuum clamps
- For wide-ranging workpiece geometries

The AP table offers wide-ranging scope for different applications such as staircase production, for instance for moving treads apart for complete processing following a separating cut. In the field of window construction, 5-sided processing can be performed without manual intervention by means of manual reclamping

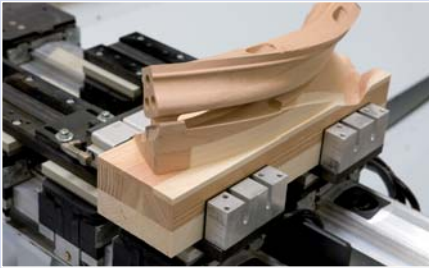

Horizontal pneumatic clamp for reliable fixture of curved handrail elements.



Different vacuum and pneumatic clamping elements guarantee precise processing of different workpieces and materials.



Automatic reclamping for 5-sided processing of window and front door staves

Automatic cutting and separation of staircase treads for all-round complete processing



Vacuum clamps and sealing cords for flexible clamping of workpieces

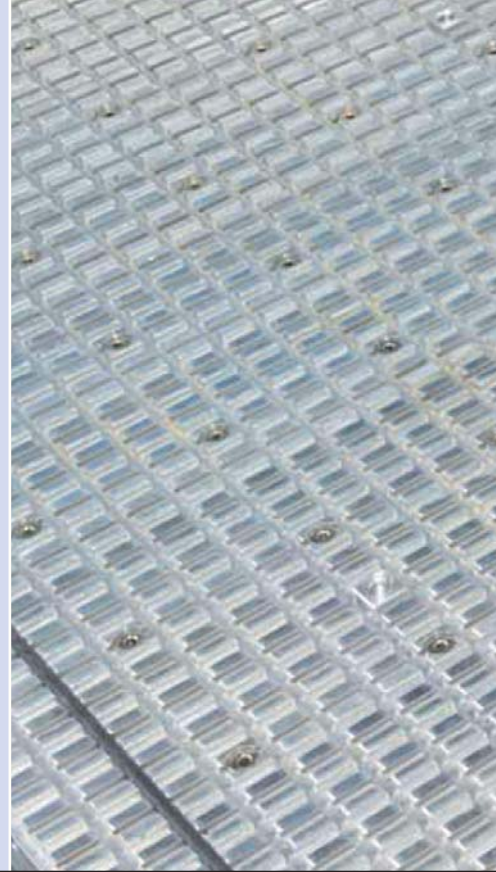

Versatile application: the matrix table

The grooved aluminium matrix table permits the positive locking of clamping elements and consequently reliable workpiece fixture even where high hogging forces are involved. The transmission of vacuum through the table construction optimizes distribution of the vacuum, reduces leaks and transmission losses and does away with the need for complex installations. Using different clamps with variable clamping heights, the matrix table is also suitable for the use of units.

More information is provided in our processing unit and clamping element catalogue



Matrix table – the universal standard solution

- Precise, flexible adjustment of the vacuum suction surface to the contours of the workpiece
- Sealing cord for insertion in the grooves ensures all-over workpiece surface contact
- Facility for narrow edge processing through the use of plug-on vacuum clamps

- Precise workpiece positioning using stop pins
- Reliable part fixture even under exposure to high hogging forces due to dovetail grooves
- Facility for workpiece clamping with spoil boards using the nesting technique

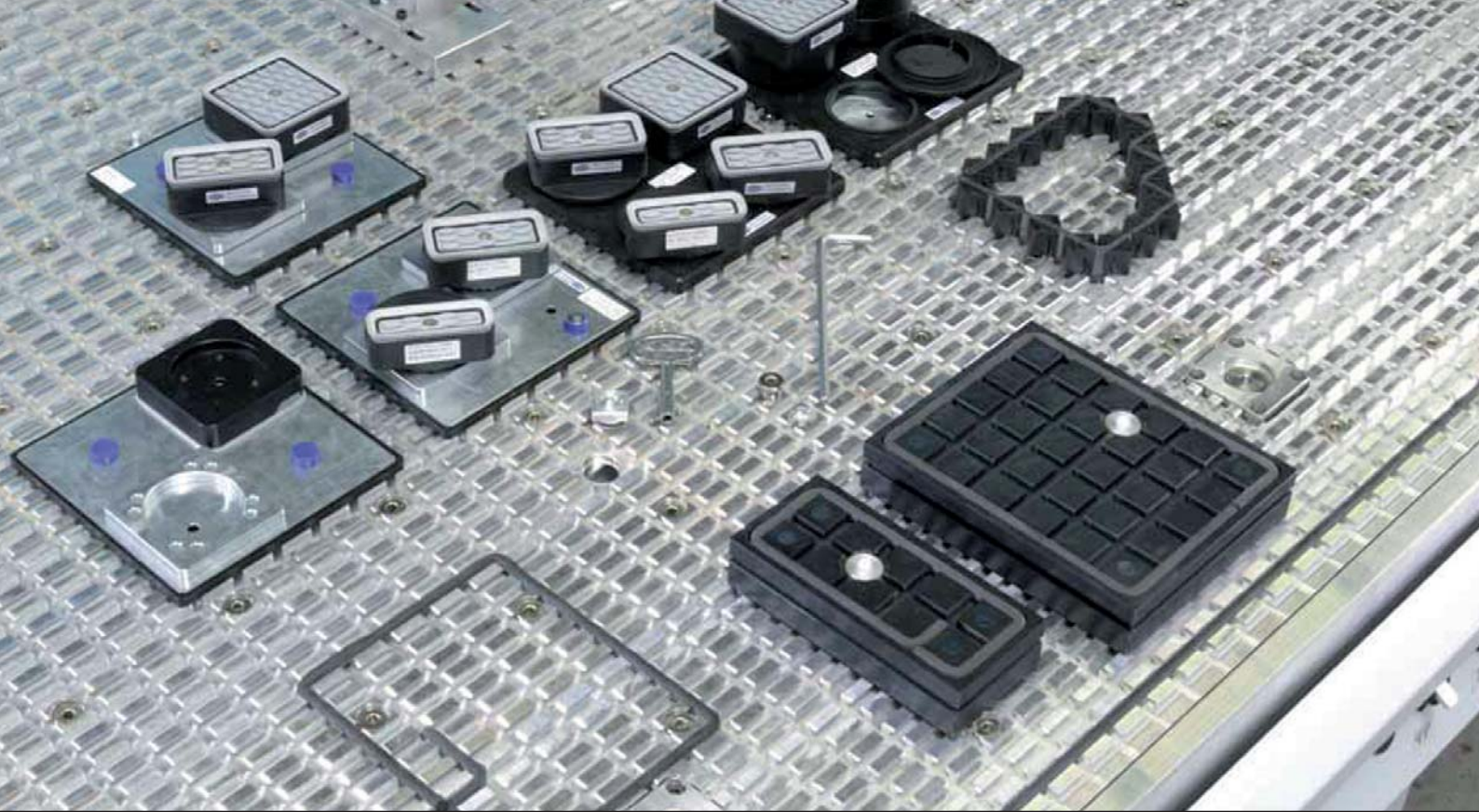

Grooved aluminium matrix table guarantees precise fixture through mechanical clamping elements in any optional location

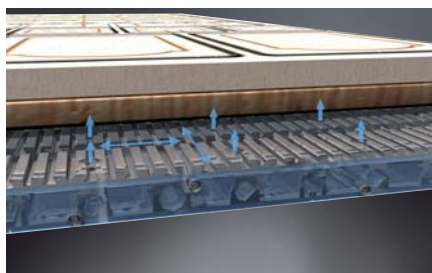

Air cushion function for easy handling of large-format workpieces



Traced trimming of furniture fronts with electronic sensoFlex tracing system



Staircase stringer processing on Flex-System

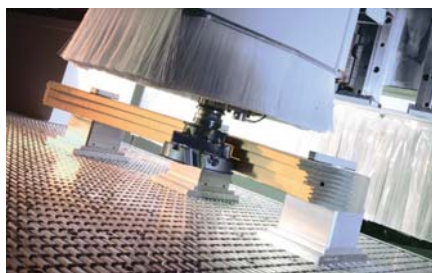

Window production with multi clamp



The Flex System also permits reliable fixture of curved workpieces such as washbasin units made of Corean

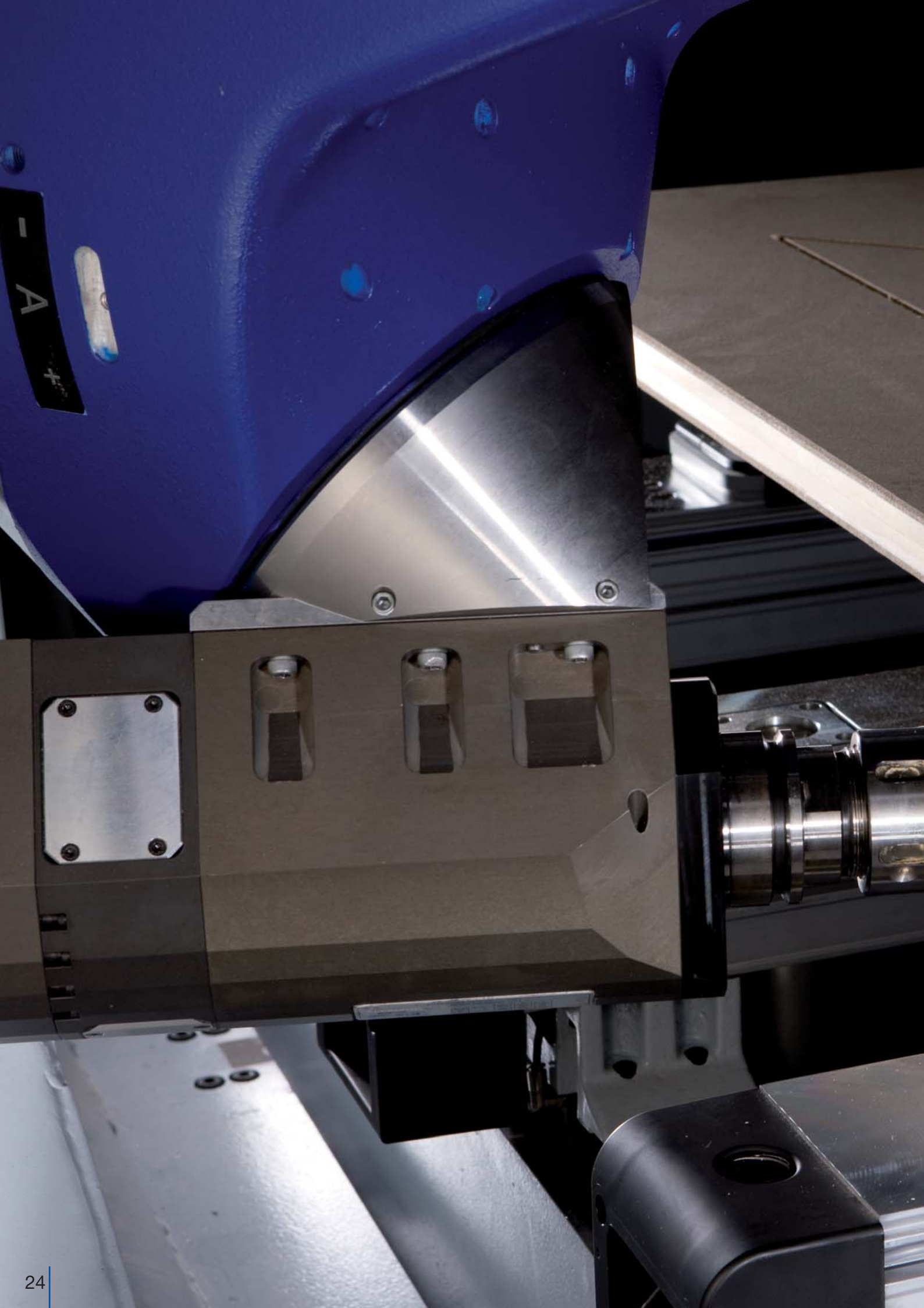

The new DRIVE5C+ five-axis trimming spindle – one for all.
Replaces the following units:



Sawing unit



Sawing/trimming/drilling unit, with swivel action



Lock case trimming unit



Horizontal planing unit



Horizontal trimming unit



Drilling/trimming unit, with swivel action



FLEX5 five-axis unit



FLEX5+ five-axis unit



More information is provided in our processing unit and clamping element catalogue

Pick-up station

An additional pick-up station for saw blades with a diameter of 350 mm saves space in the tool changer.

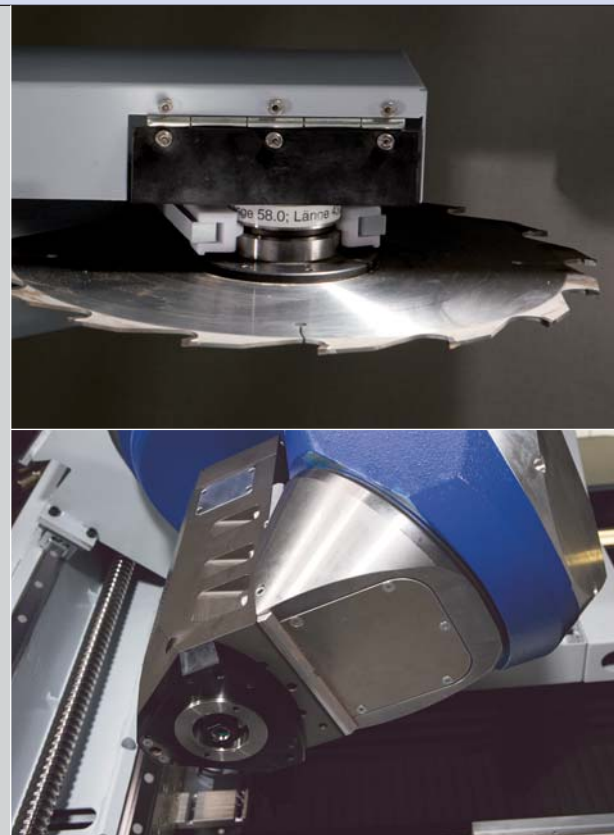

Tool changer

Tool storage facility with up to a total of 28 slots (10 plus 18 slots) offers a basis for the flexible application of different tools and units even with large diameters up to 200 mm. Even saw blades with a diameter of 350 mm for extreme cutting depths and also shift cuts can be fitted (14-slot or 18-slot changer)

Unit interface for the flexible use of different units for

- Traced trimming
- Sanding
- Corner notching



Corner notching unit
e.g. for sink cut-outs in kitchen worktops



Traced unit for radius trimming of workpiece edges

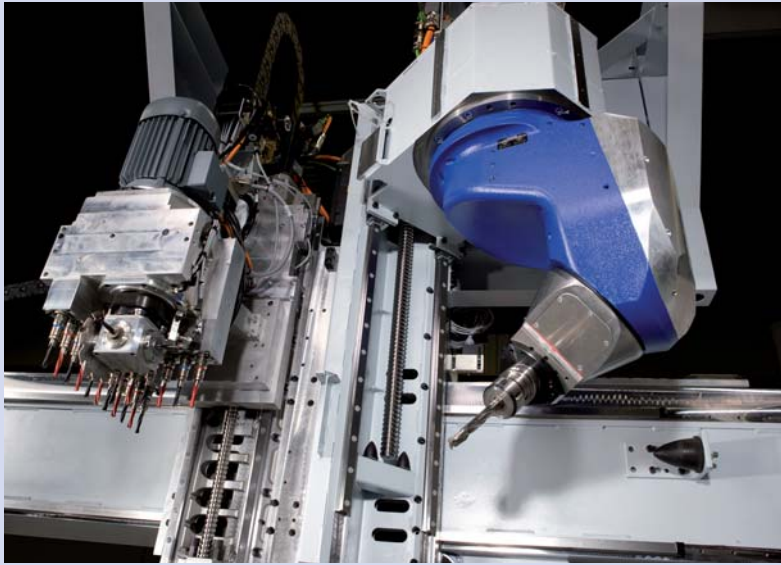

Extreme Z axis stroke permits processing heights of 300 mm

A Z axis with a traversing path of 600 mm guarantees a real processing height of 300 mm including clamping elements, even when working with large tool lengths of 230 mm and a saw blade diameter of 350 mm

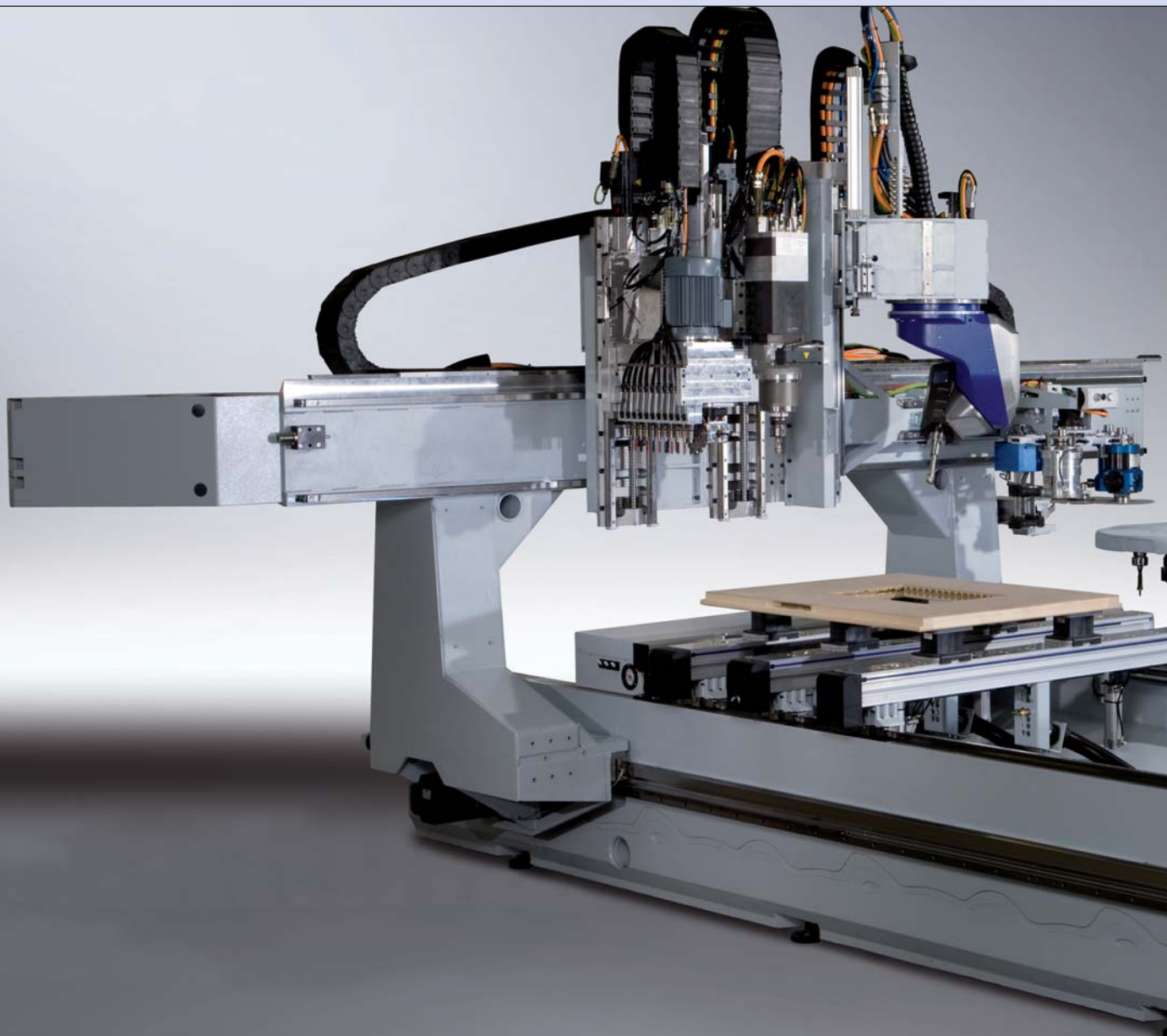

Several processing units

Our working spindle technology sets whole new standards, enhancing both the performance and flexibility of our machines. For instance the enormous benefit of a controlled working spindle with electronic speed monitoring. Other highlights include the vibration sensors for preventing damage to the trimming spindles, the sensoFlex tracing system and 5-axis technology. Select your spindle to suit the needs of your present and future product spectrum.

Double spindle technology

The highly rigid gantry beam with two dynamic drives in the X direction, in conjunction with up to three Z axes forms the basis for mounting two trimming spindles and one drilling head. While one of the trimming spindles or the drilling head is in use, a tool change can be performed at the same time.



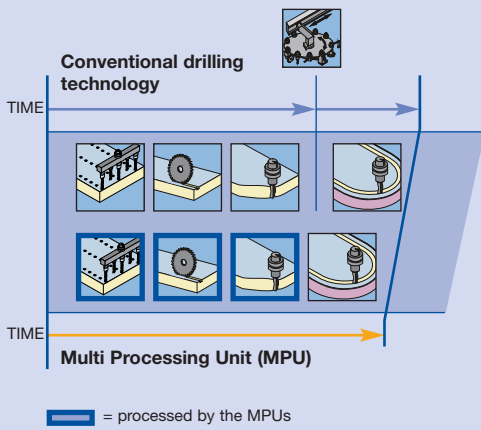

The multifunction capability of the Multi Processing Unit permits sizing, sawing and drilling without tool changes. As the MPU affords 360° swivel capability, these processing operations can even be performed at “any” angle. While the MPU is operational, tools can be exchanged into the working spindle, drastically reducing downtimes in favour of higher productivity and lower piece costs. An additional add-on spindle with an output of 6 kW offers additional scope for processing without the need for tool changes.

High-Speed drilling technology

High-speed drilling heads with 13, 21 or 30 spindles including sawing reduce the number of drilling cycles or alternatively provide drill bits with different diameters without the need for resetting. A patented quick-change system permits fast drill changeover without the need for tools, and mechanical spindle clamping guarantees that drilling depths are reached even when working with hard materials.

Automatic central lubrication

An automatic central lubrication system reduces the amount of work required for maintenance and ensures a long service life even in industrial multiple-shift operation.

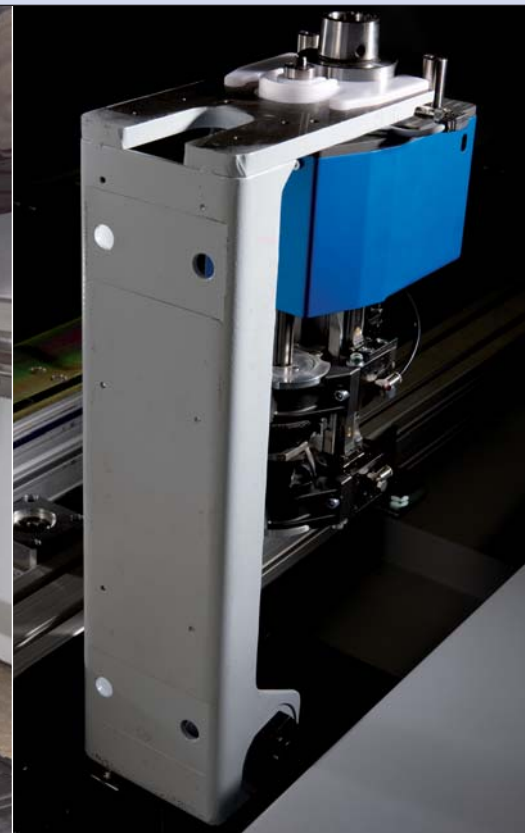

sensoFlex tracing system

Benefits of the **sensoFlex** tracing system include:

- Perfect workpiece quality – the traced spindle compensates for unevenness and unwanted tolerances
- Tracing facility for different tools ensures complete flexibility
- Functional upgrading through the facility to use wide-ranging different units

Enclosed trailing cables and linear guides

The enclosed arrangement of trailing cables and covered linear guides provides optimum protection from dust and waste pieces, and increases service life over years

Tool transfer station

A tool transfer station increases operating convenience and helps prevent errors in the equipment of tool changer slots for improved safety

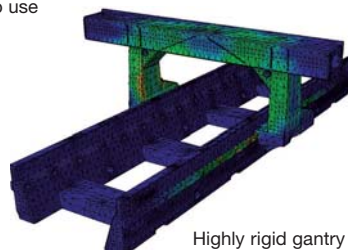

Highly rigid gantry construction by means of finite element calculation optimized for a high standard of workpiece quality

Programming software and machine control

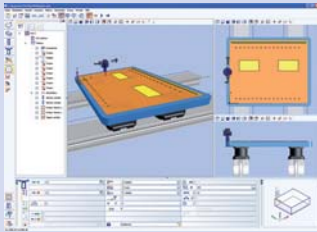

woodWOP – streamlined operations through fast programming

- Greater programming reliability using 3D graphic displays of workpiece processing operations and clamping elements
- Faster data input through simple, direct navigation
- Higher operating convenience through a redesigned user interface featuring freely adjustable windows, multiscreen capability, language-neutral input masks, graphic help functions and much more.
- Biggest forum for CNC programming in the Internet: www.woodWOP-Forum.de



Visualization of working spindle vibration data

- For detection of critical vibrations during processing
- Display of a warning and cut-off limit
- Permits monitoring of tool / balancing quality
- Tracing of chatter marks
- Reduced servicing costs
- Increased operating safety

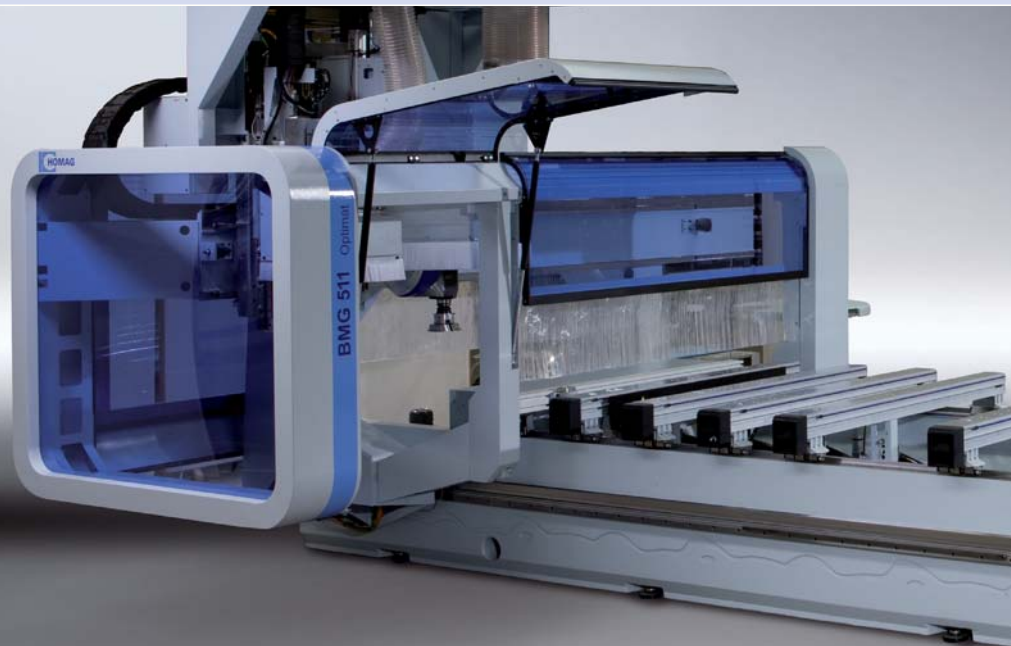

woodWOP production engineering station – programming from the comfort of the office

- Programming while ready generated programs are running on the machine
- Data transmission via standard USB port at the machine or over a network connection directly from the office

woodWOP DXF-import – the CAD interface

- For transfer of workpiece geometries and defined processing operations
- Data transfer from CAD systems in international DXF format

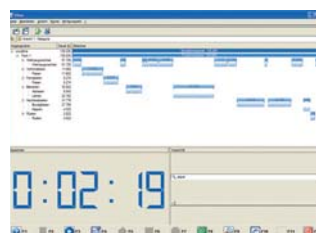

woodTime – simulation in a class of its own

- Simulation based on a virtual machine with real CNC core controlled by data from the relevant customer machine. This allows real CNC machine behaviour to be simulated with almost 100% accuracy in production engineering
- Simulation of all machine processing operations at the workpiece including stock removal
- Simulation of 5-axis processing operations in woodWOP format and from external DIN codes
- Storage and transfer of simulation runs

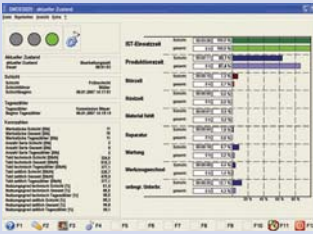

Machine data acquisition MDA – for a productive environment

- Registration of piece numbers and ACTUAL operating times at the machine
- Integrated maintenance indication for optimum planning and execution of necessary maintenance work
- Optional professional version permits detailed breakdown and logging of registered data

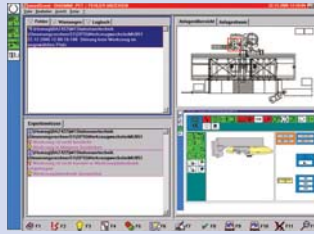

woodScout – help in your own language

- Optional high-performance diagnostic system
- Graphic display of the fault location at the machine
- Easily understandable plain text error messages in different languages
- Learning capability through the assignment of root causes and remedial actions (expert knowledge)



Tool service life determination – for a complete overview

- Module for monitoring and documentation of tool service life
- Machine availability and workpiece quality are enhanced by the timely exchange of tools
- Cost reduction through optimum planning of tool deployment and comparative analysis of tool life

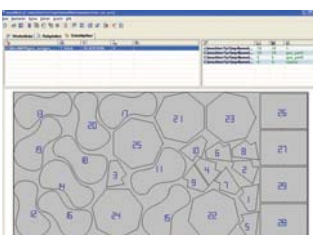

woodNest – reduction of cutting waste

- Nesting software for automatic interleaving of workpieces on a raw panel
- The nesting technique combines cutting and finish processing
- Reduced material costs and overall processing times

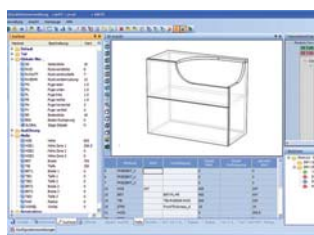

Interface to trade-specific software

- For trouble free linkup of trade-specific software packages
- For transfer of already existing data from production engineering
- Countless links to all reputable room planning systems, window trade-specific software, staircase software, CAD/CAM systems and ERP/MRP systems

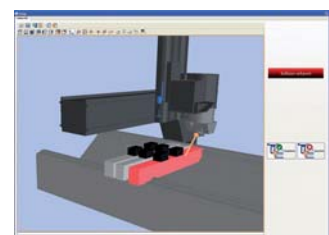

collisionControl – permanent safety for your machine

- Monitors possible collisions between machine components and clamps at the machine during processing
- Automatic machine stop in the event of an impending crash situation
- Display of the crash situation in the form of a snapshot with collision bodies shown up in colour
- Depiction of the machine as a moving 3D model in live operation



LifeCycleCost reduces unit costs

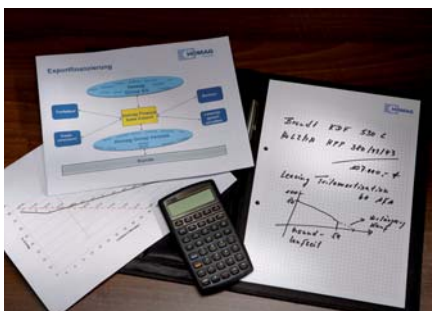

Unit cost reduction through

Optimum financing

- HOMAG Finance offers optimized financing concepts based on individual business administration requirements
- The outstanding value stability of HOMAG processing centres offers benefits in terms of leasing and subsequent replacement investment

High level of processing quality “without” finish processing

- A highly rigid solid machine construction made of innovative SORB TECH material reduces vibrations and increases tool life by up to 20 %
- Vibration sensors in the working spindles automatically reduce feed rates under high levels of stress (such as knots in solid wood) or in case of unbalanced tools
- Tool life determination software optimizes tooling costs and optimum workpiece quality

Reduction of labour costs

- Automatic part handling with robot systems or linear feeders
- Fast, simple operating capability of machines

High degree of machine availability

- World-wide round-the-world service reduces machine downtimes
- TeleServiceNet – our “eye” into the machine eliminates the need for costly service callouts
- woodScout diagnostic software – intelligent self-help for all machine operators

Low energy costs

- Intelligent stand-by operation reduces energy costs during break times or in case of partial capacity utilization by up to 10 %, saving up to 8,000 kwh of power per year*
- A flap control system switches the volumetric flow of the extraction system to the processing units in use, reducing extraction costs by up to 20 %, corresponding to energy savings of up to 12, 000 kwh per year*
- Cooling of the working spindle by means of water ring vacuum pumps saves an additional 2,000 kwh per year*



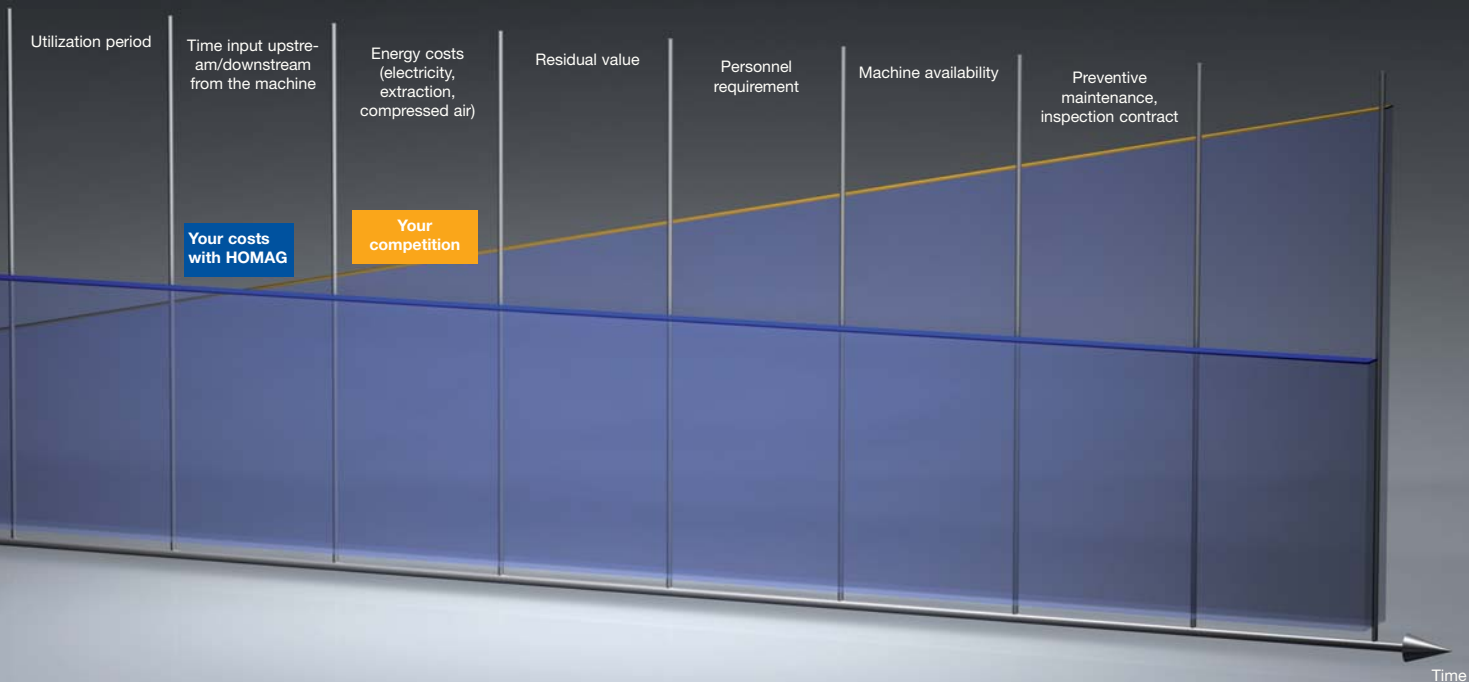

Machine utilization period

- Facility for continuous upgrading of processing centre functionality using standardized interfaces ensures compliance with future production requirements
- The HOMAG modification department offers solutions to address major retrofitting requirements, ensuring a high degree of investment security over years

Effective production engineering

- Links to trade-specific software packages and CAD/CAM systems reduce program generation times and make use of already existing data
- woodMotion determines processing times for optimum capacity planning and maximum machine time utilization
- Collision monitoring prevents faults by advance testing of programs under “real conditions”

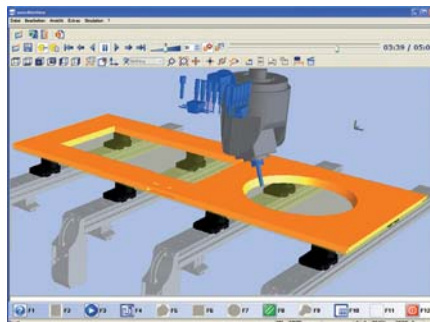

Preventive maintenance

- Regular inspections and preventive maintenance help avoid machine faults and extend service life
- MDA software informs the machine operator about scheduled maintenance requirements and provides cost transparency for calculation

* Based on one BMG 512 in single shift operation

Highlights to get you ahead

Technical data BMG 500

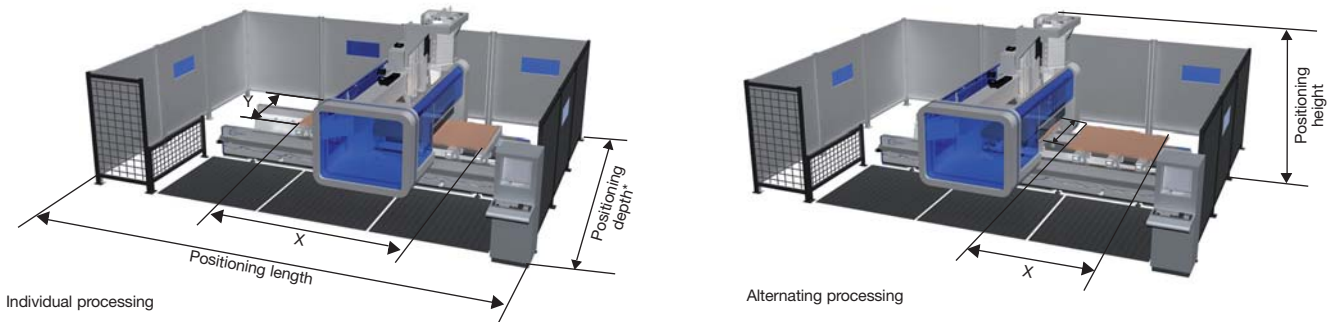







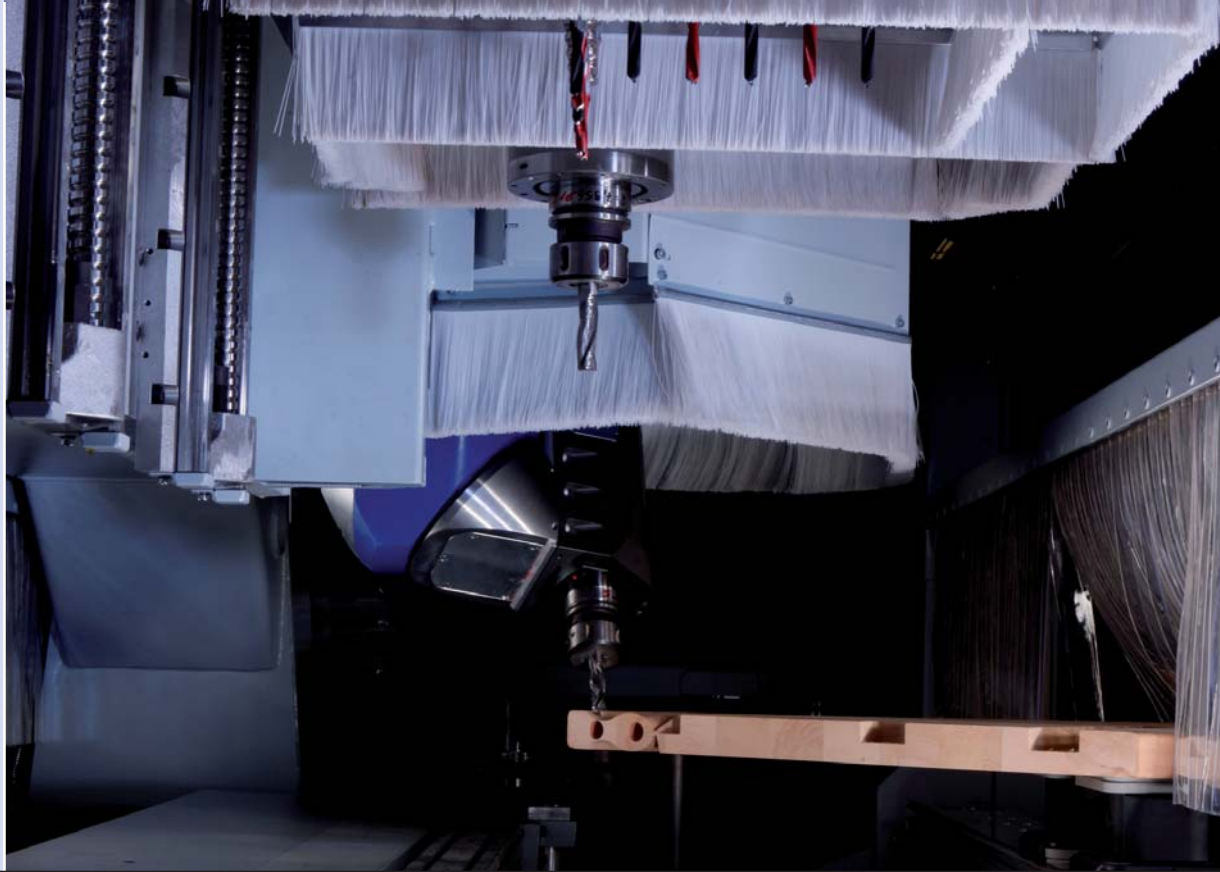

| Machine type | Table variants | X = Workpiece length [mm] | | | | | | Y = Workpiece width [mm] | | | | Workpiece thickness [mm] |
|---------------|----------------|---------------------------|--------|--------|-----------------------|-------|-------|-----------------------------------|-----------------------------|-----------|--|----------------------------|
| | | All units | | | | | | All units 4-axis Front stop | with tool diameter 25 mm | | 5-axis A = 90° with tool diameter 230 mm | with tool length 230 mm |
| | | Individual processing | | | Altern. processing CE | | | | Front stop | Rear stop | | |
| | | 33 | 40 | 60 | 33 | 40 | 60 | | | | | |
| BMG xxx/xx/12 | K, AP, R | 3.300 | 4.000 | 6.000 | 1.025 | 1.375 | 2.375 | 1.100 | 1.325 | 1.550 | 1.100 | 300 |
| | | 129,9" | 157,5" | 236,2" | 40,4" | 54,1" | 93,5" | 43,3" | 52,2" | 61,0" | 43,3" | 11,8" |







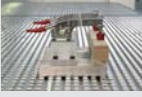

| Machine type | Table variants | Positioning length [mm] | | | Positioning depth [mm] | Positioning height [mm] |
|---------------|----------------|-------------------------|----------|--------|------------------------|-------------------------|
| | | 33 | 40 | 60 | | |
| | | BMG 511/xx/12 | K, AP, R | 7,100 | | |
| | | 279,5" | 307,1" | 385,8" | 204,7" | 118,1" |
| BMG 512/xx/12 | K, AP, R | 7,100 | 7,800 | 9,800 | 5,600 | 3,000 |
| | | 279,5" | 307,1" | 385,8" | 220,5" | 118,1" |

Technical data and photos are not binding in every detail. We reserve the express right to make changes in the interests of further development.

* Depending on the machine configuration

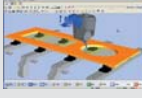

| | |
|---|--|
| Basic machine | |
|  | Solid heavy-duty basic machine made of vibration absorbing material SORB TECH |
|  | Highly rigid gantry design with two dynamic drive systems in the X direction for high productivity and precision |
|  | Large viewing window at the front / side for an optimum view of processing operations |
| K-table | |
|  | Set-up system with LED chains for rapid, safe positioning of consoles and clamping elements (option) |
| AP-table | |
|  | Fast table positioning to reduce set-up times (appr. 35 secs.) |
| R-table | |
|  | Aluminium matrix table with dovetail grooves for mechanical fastening of clamping elements |
| Drilling head | |
|  | Mechanical drilling spindle locking mechanism for "guaranteed" drilling depth when working with "hard" materials and high feed rates |
|  | Multi Processing Unit with supplementary spindle for fewer tool changes and to reduce the number of units (option) |

| | |
|--|--|
| 5-axis working spindle | |
|  | DRIVE5C+ performance pack with pneumatic transmission for processing operations such as traced trimming (option) |
|  | Pre-tensioned, backlash-free cross roller bearings for a high level of rigidity and interpolating processing |
| Additional 4-axis working spindle | |
|  | Electronic tracing system sensoFlex for use with different tools |
| Tool changer 1 | |
|  | Maximum saw blade diameter in tool changer 350 mm |
| Tool changer 2 | |
|  | 10 slots for tools and units |
| Additional tool slots | |
|  | Pick-up station for saw blade diameter 350 mm with coupled motion in the X axis and also for use with alternating operation (option) |
| Software | |
|  | woodMotion processing simulation at the workpiece based on the CNC core for reliable programming of complex workpieces (option) |
|  | collisionControl analyses based on the CNC core for the prevention of machine damage due to collision (option) |



A member of the HOMAG Group



HOMAG Holzbearbeitungssysteme AG

Homagstraße 3-5

72296 SCHOPFLOCH

GERMANY

Tel. +49 7443 13-0

Fax +49 7443 13-2300

info@homag.de

www.homag.com