

CNC Gantry-Processing Centers Vantage 200

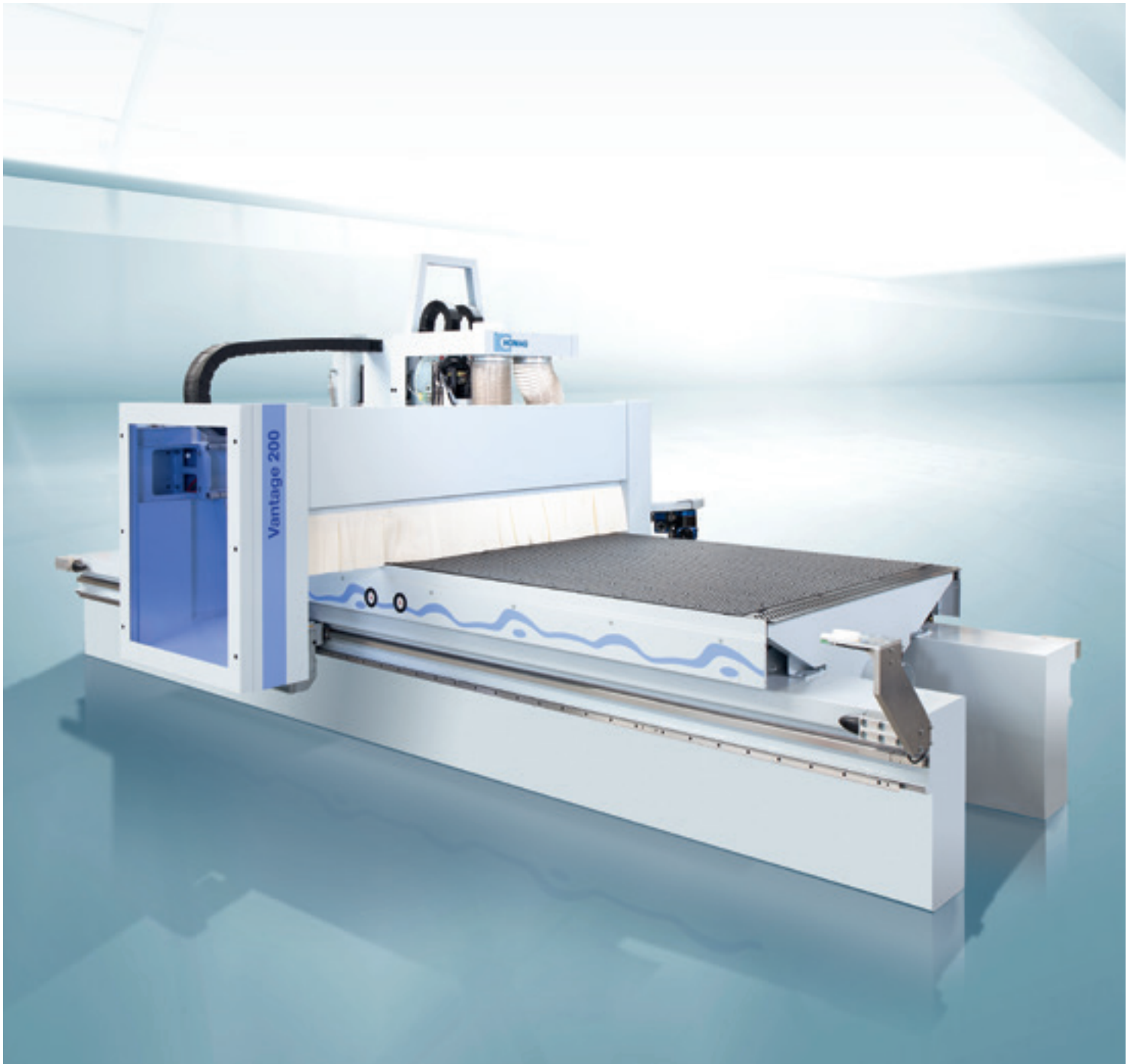





Vantage 200 – The power pack among our nesting solutions The Result: **YOUR SOLUTION**

Our CNC processing centers today already offer technology of the future. Why? – Tradition. »Made in Germany« is our motivation and our commitment. Customers around the world have come to expect the highest standards from this quality label. And we meet those expectations. Here you will find more: www.homag.com

Contents

- 04 Vantage 200 | Highlights
- 06 Options
- 08 Nesting areas
- 10 Software | Machine
- 11 Process optimization
- 12 Units
- 14 Nesting solutions
- 15 Technical data

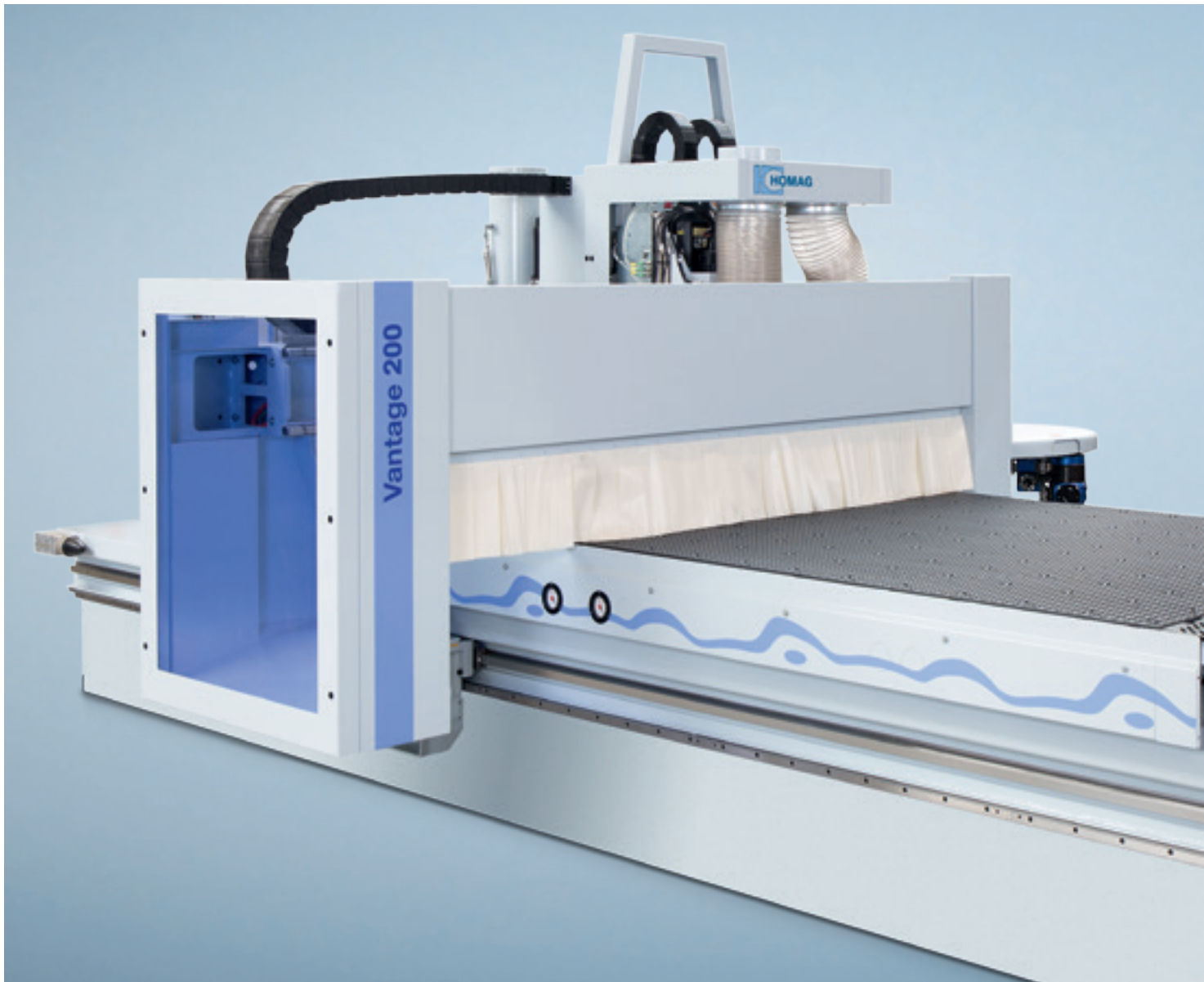

Configuration

- Standard:
13,4 HP (10 kW) HSK routing spindle
- Optional:
17,7 HP (13,2 kW) HSK routing spindle



Tool changing system

- 14-fold tool changer moving in X-direction
- Tool pick-up station



MATRIX table PRO

- High flexibility
- Individual division into various vacuum areas by manually placing plugs

Vantage 200

THE POWER PACK AMONG OUR NESTING SOLUTIONS

Our nesting machines enable cutting-optimized processing and dividing of plateshaped materials. We divide the typical nesting areas into four areas.

The typical application areas of nesting:

- Creating components for carcass furniture
- Dividing and refining of furniture fronts
- Processing of frame furniture
- Creating components for the caravan sector and structural-facings sector

Various possibilities for the automation of the material handling ensure a high time saving and an even more effective work.

Highlights:

- Gantry style – for highest precision over the total working width
- Sealed »long-life« linear guiding system
- High acceleration
- Vector speed X/Y 130 m/min
- The whole working field is reachable with all processing tools
- Electronic surveillance of all stops
- Efficient use of energy through high vacuum performances and simultaneously minor power consumption
- Optimization software
- Remaining parts handling



2 CNC-controlled Z-axes in combination with drilling block

- Optimal dust extraction and bigger operative range for processing units
- Weight distribution of the mass (processing units) to the two Z-axes = more stability, higher processing quality

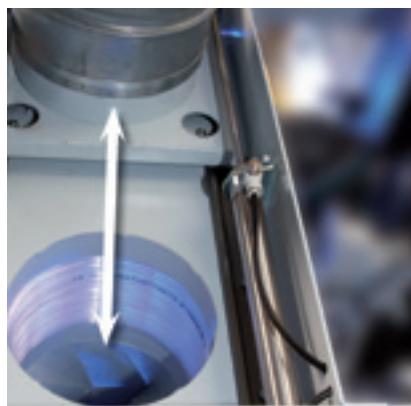

Program-controlled extraction connection

- For an optimum extraction behavior and economic use of extraction energy (ecoPlus)

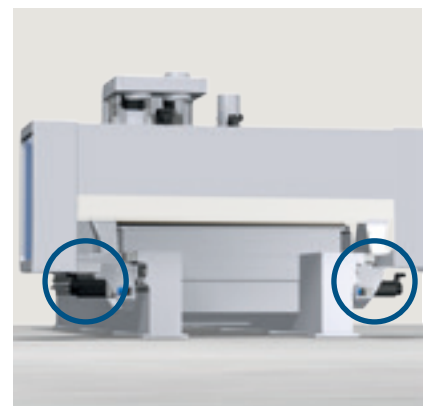

Synchronous drive

- 2 synchronised digital servo-drives in X-direction guarantee highest processing quality

Options

WOULD YOU LIKE SOMETHING EXTRA? Our options provide all opportunities for a perfect adjustment of your nesting machine to your requirements.

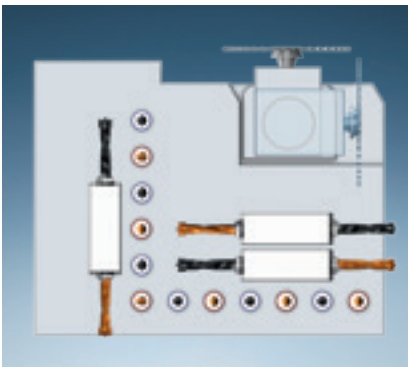

High-Speed 7500 Drilling block | 12 spindles

- 12 vertical drilling spindles
- 4 horizontal drilling spindles in X
- 2 horizontal drilling spindles in Y
- 1 grooving saw \varnothing 125 mm (0° / 90°)



High-Speed 7500 Drilling block | 21 spindles

- 21 vertical drilling spindles
- 6 horizontal drilling spindles in X
- 2 horizontal drilling spindles in Y
- 1 grooving saw \varnothing 125 mm (0° / 90°)

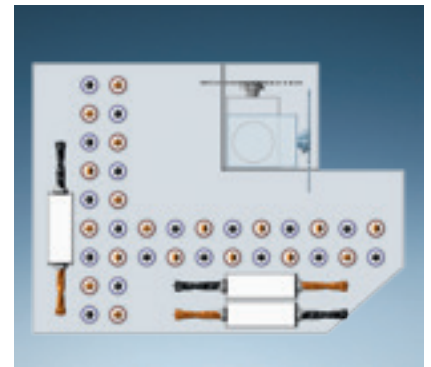

High-Speed 7500 Drilling block | 36 spindles

- 36 vertical drilling spindles
- 4 horizontal drilling spindles in X
- 2 horizontal drilling spindles in Y
- 1 grooving saw \varnothing 125 mm (0° / 90°)



High-Speed 7500

- Spindles with 1500 - 7500 RPM incl. the patented quick change system

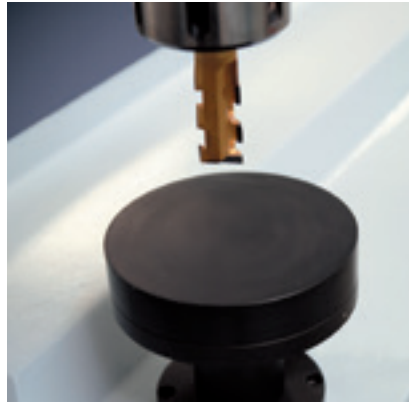

Tool length control

- Following the tool change a tool length control is carried out and compared with the integrated tool data file



Tool box »STARTER KIT«

- Top equipment – from the very start



Tool changer

- Tool changing system, fixed behind the machine, 28, 42 or 56 places



Clamping elements

- Different clamping elements available as option



Vacuum lever for raw panel positioning

- For automatic positioning of the raw panels against the fence guide.



Barcode connection

- Barcodescanner / -software
- Supported barcodes:
1D – Barcode
2D – Data Matrix Code
- Every workpiece is exactly identified for the further workpiece flow

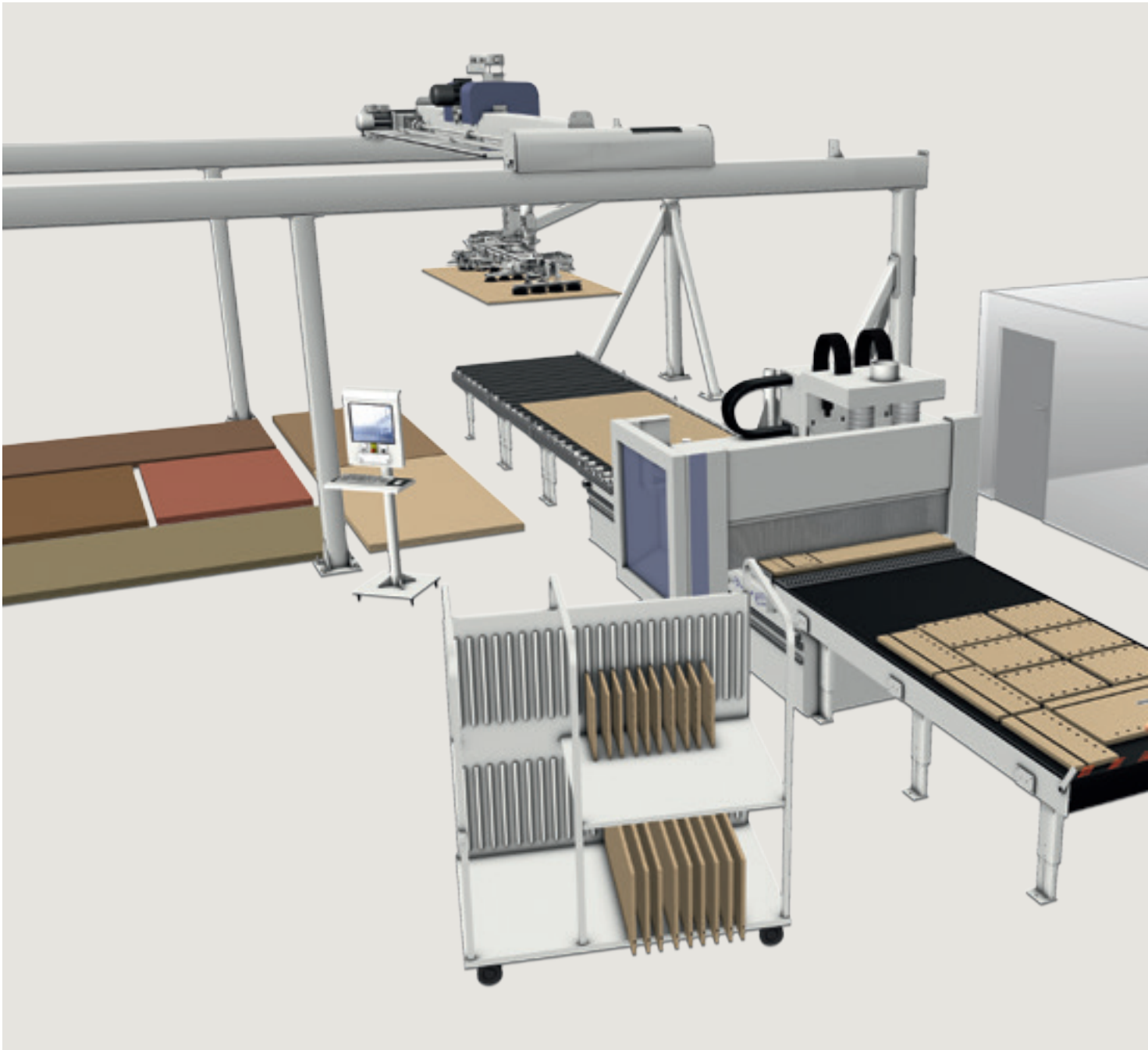

Nesting: one procedure – many possibilities...

THE TYPICAL APPLICATIONS OF NESTING are creation of furniture, as well as creating components for the caravan sector and structural-facings sector. Different materials can be processed and finished, e.g. plexiglass, plastic sheets, foam, carpet, veneer or wood-based materials.



FURNITURE MANUFACTURING

- Routing of all components required for a carcass
- Drilling, grooving in just one cycle
- Clamping elements also provide horizontal drilling
- Fast dividing and refining of furniture fronts from one workpiece – everything in one cycle!

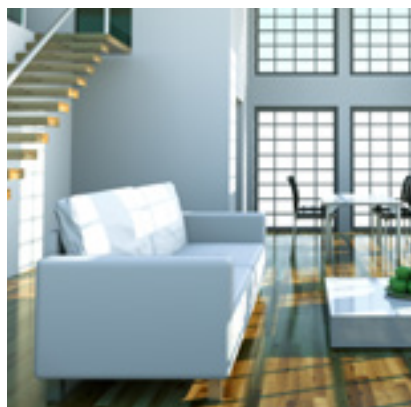

FRAME FURNITURE

- High degree of utilization due to easy handling of “free” formed parts
- High flexibility in the further processing by the use of units

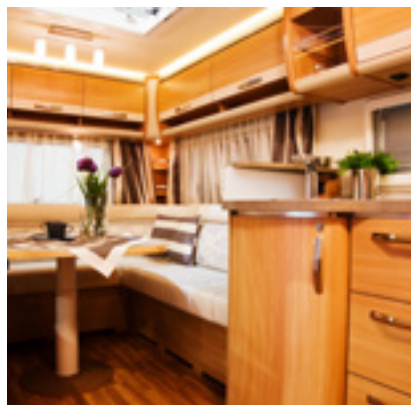

CARAVAN CONSTRUCTION

- Proper cutting of e.g. foam material, carpets or veneer
- Processing of plastics and honeycomb panels



STRUCTURAL-FACINGS SECTOR

- High flexibility of processing possibilities of e.g. block elements, plexiglass or acryl glass
- High gloss polishing routing

powerControl with powerTouch

- 21,5" Full-HD multitouch display with wide screen 16:9
- Provision of teleservice capability
- USB frontside bus
- Ethernet connection 10/100 Mbit
- Ergonomic hand terminal
- Position of switch cabinet freely selectable (right/left)

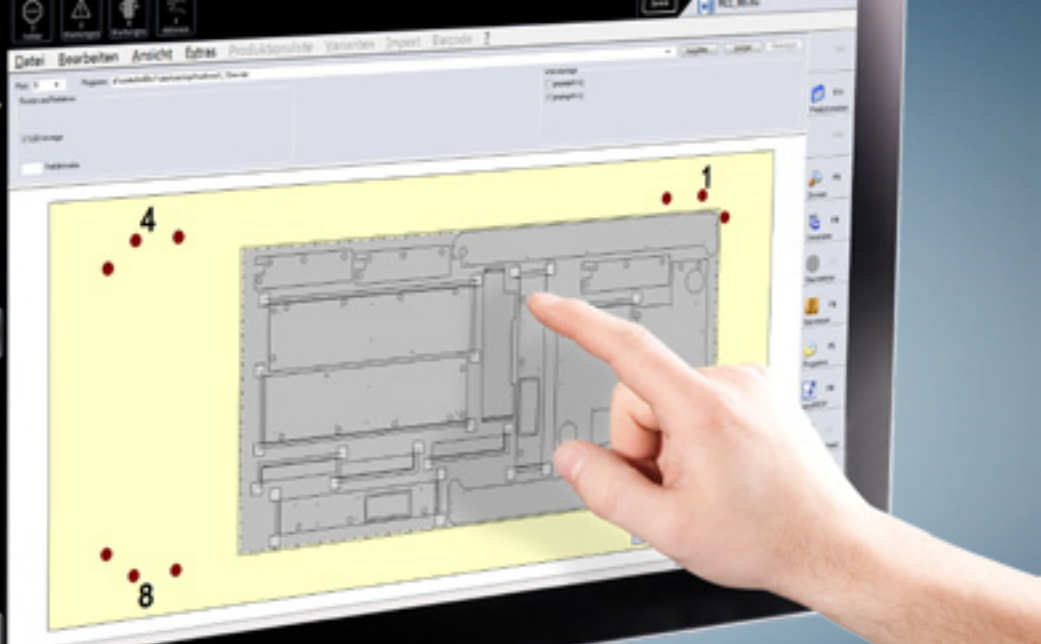

Software | Machine

Our machines are equipped with everything needed for productive use as standard. In addition, a wide range of software modules can be supplemented to create the optimum configuration.

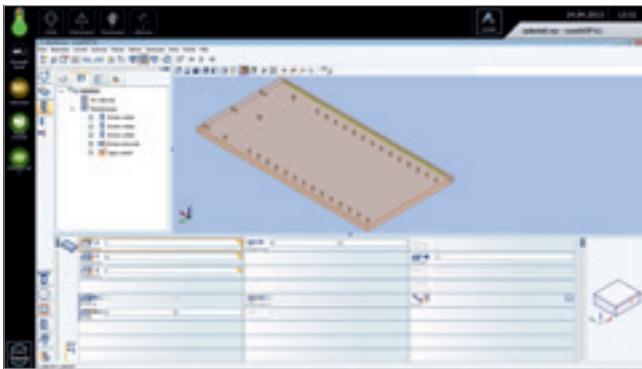

woodWOP

- Modern software based on Windows®
- Import of CAD files in DXF format
- More than 30.000 installations worldwide
- Worldwide largest forum for woodWOP



Production list software

- For management and creation of product lists for individual manufacturing



MCC

- Simple control of main machine functions through soft keys
- Graphical loading

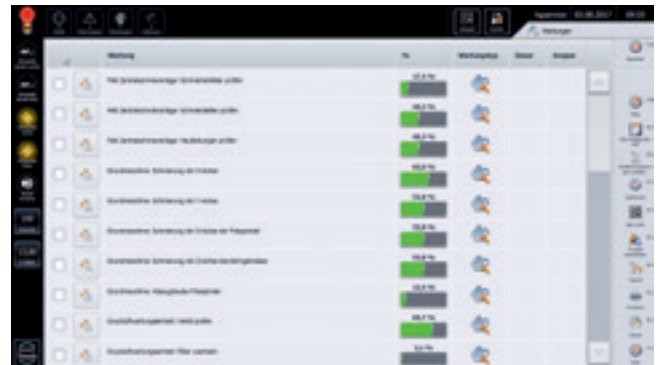

MMR Basic

- Machine Data Recording – collecting and evaluating machine states via time meter and event meter
- Display and logging of maintenance measures

Process optimization

CUT RITE, THE OPTIMIZATION SOFTWARE OF THE HOMAG, is used for cutting boards on sawing machines as well as nesting machines. The modular structure of the software allows users already controlling their sawing machine via Cut Rite to integrate the nesting module without problems. Plus, customer processes can be made even more efficient by woodCAD|CAM and residual parts management.

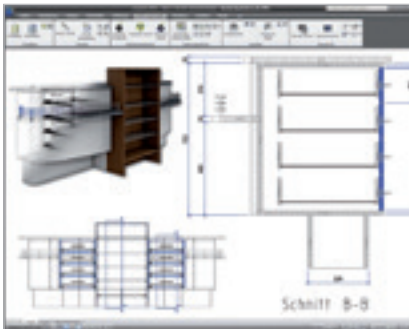

woodCAD|CAM

- Parametric design in 3D
- Seamless data flow in operation
- Bill of materials, cutting to size and cost estimation
- CNC data for HOMAG Group machines
- Bar code generation
- Photorealism for sales negotiations



Residual parts management | Basic

- Labels for residual parts from Cut Rite
- Manual management

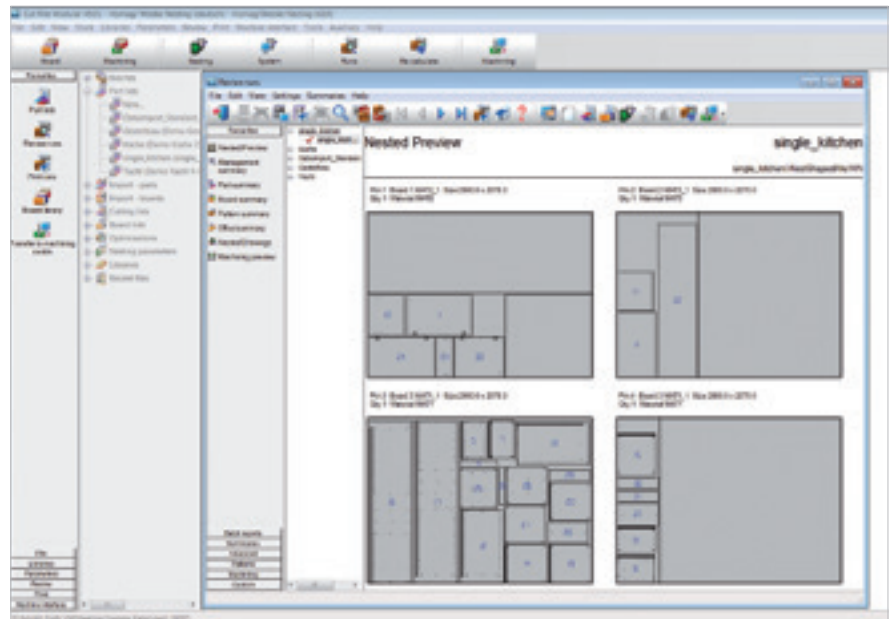

Optimization software: woodNest Basic and Cut Rite Nesting

- Optimization and generation of cutting plans for rectangular and free-formed workpieces (woodNest Basic: manually | Cut Rite: automatically)
- Functions with Cut Rite:
 - Import of parts lists, e.g. from Excel, or direct import of woodWOP programs
 - Additional milling strategies “bars”, “common line” and “stay down”
 - Includes material management, parts sorting by material type, and label printing in the office
 - Manual editing of cutting plans



Residual parts management | Advanced

- Automatic management within the storage database
- Manual positioning in automatic mode
- Labels for residual parts can be produced on the machine itself

Residual parts management | Professional

- Automatic residual parts handling for nesting concepts in conjunction with storage solutions from HOMAG Automation
- Only in combination with residual parts management | Advanced



Units

INNOVATION. PRECISION PASSION. Over 20 years of experience in the development of units are reflected in the advanced stage of today's unit engineering. The HOMAG units are distinguished by their extreme rigidity, outstanding precision and stability.



C-axis (0-360°) for the use of units



Extension to FLEX5 consisting of FLEX5 interface and FLEX5 unit

HIGH PERFORMANCE UNITS ensure optimum lubrication of gear components for prolonged operations.

FLEX5



HIGH PERFORMANCE
Drilling/Sawing/Routing



HIGH PERFORMANCE
Sawing Ø 220 mm



HIGH PERFORMANCE
Planing unit | Tool diameter max. 120 mm



Drilling/Routing/Sawing
2 spindles
(also available as HIGH PERFORMANCE unit)



Drilling/Sawing
swivelling (0° - 90°), Ø 180 mm
(also available as HIGH PERFORMANCE unit)

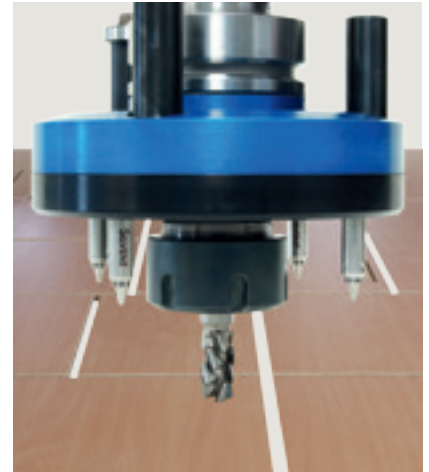

Routing
with 4-fold blowing nozzle



Tracing routing unit with tracing ring
Ø 70 mm | Ø 130 mm



Cutting unit
1 cutting blade | 10 mm cutting surface

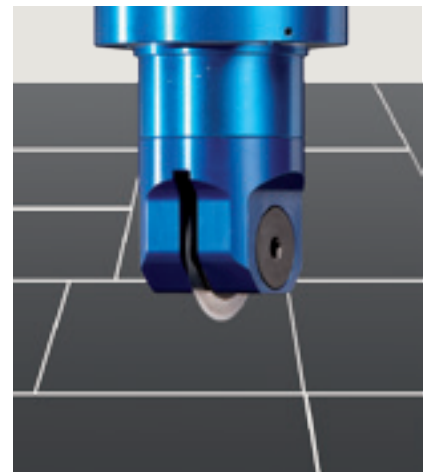

Foil cutting unit
1 cutting wheel | Ø 75 mm



Drilling/Routing
swivelling cranked (0° - 90°),

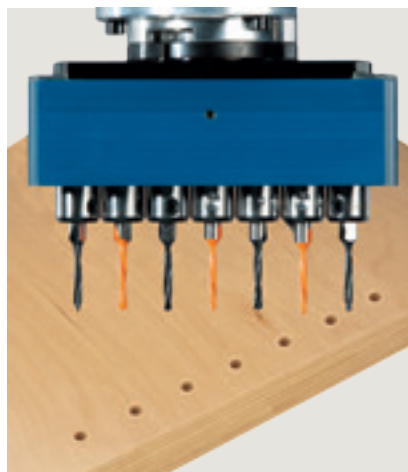

Drilling
7 spindles, 25 mm raster

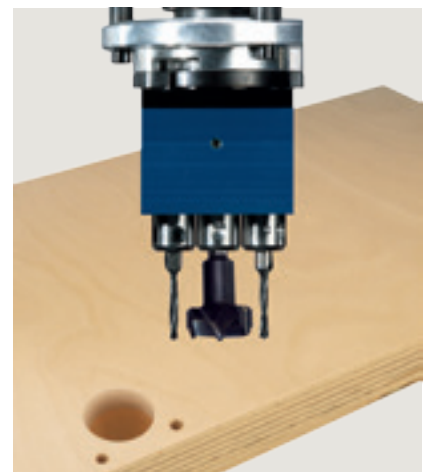

Fitting drilling head
3 spindles

Discover the possibilities...

WITH THE NESTING SOLUTIONS you are always well-advised. Whether manual feeding of the workpieces, by lifting carriage or by storage – we have always the proper concept for your application. You wish to identify, for example, the workpiece flow exactly by barcode? No problem!



Nesting „Start-up“



Nesting concept 1

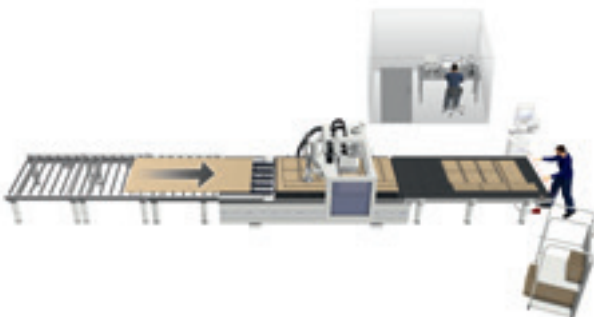

Nesting concept 1R



Nesting concept 2

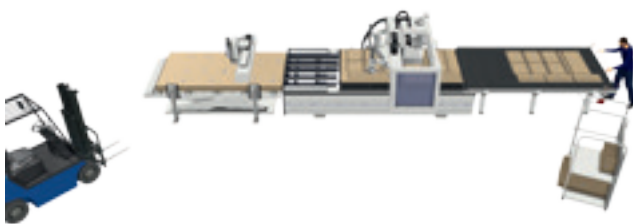

Nesting concept 3



Nesting concept 3R

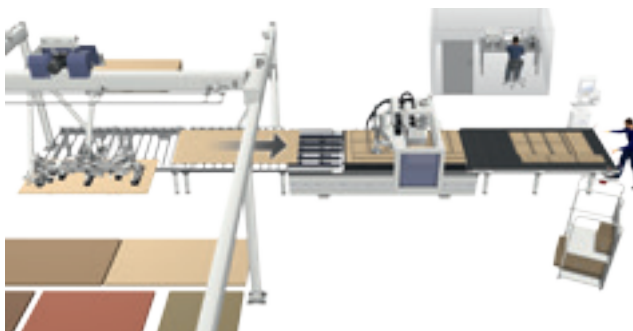

Nesting concept 1R with storage



Nesting concept 3R with storage

Technical data

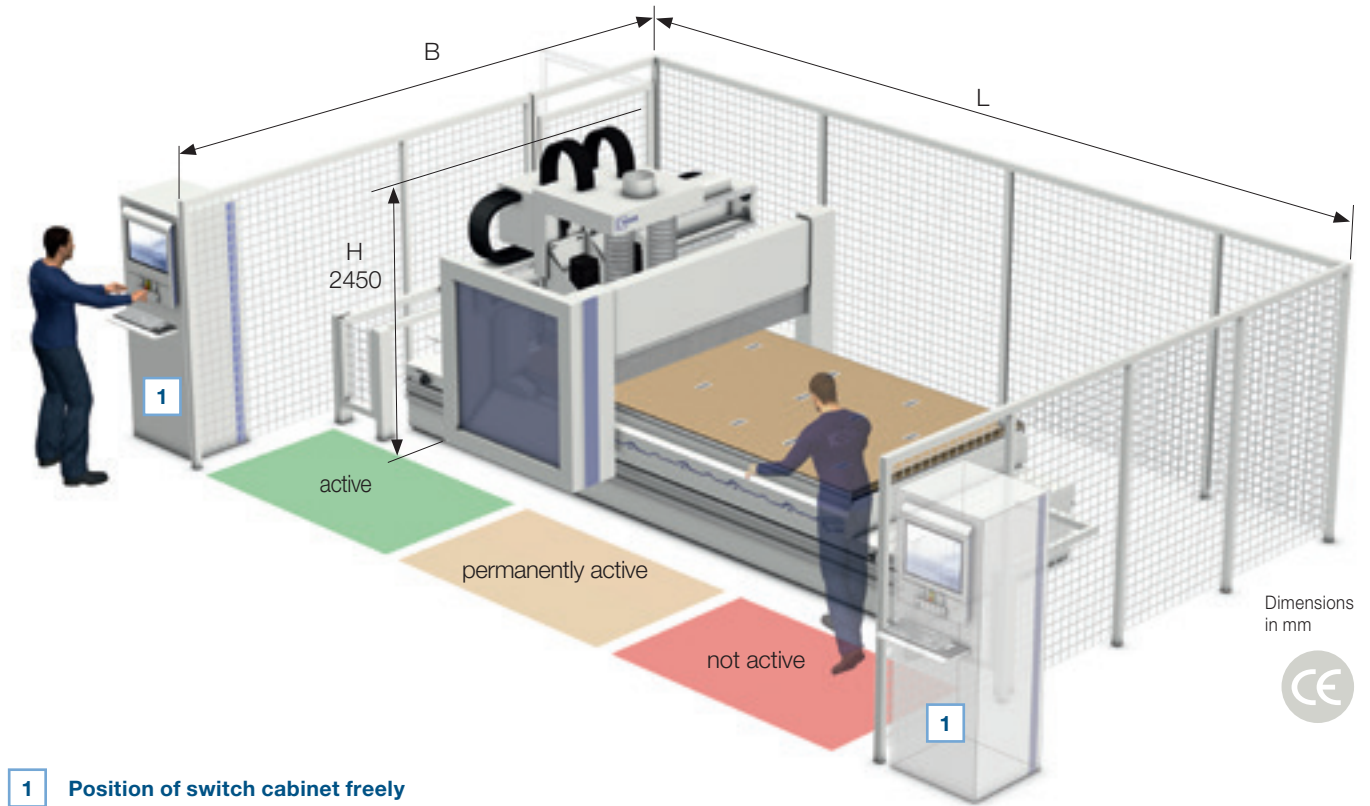

Dimensions in mm



1 Position of switch cabinet freely selectable

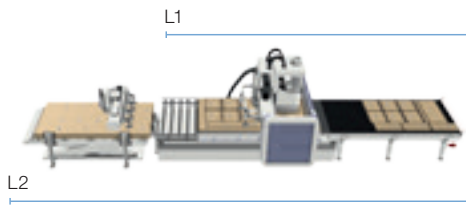

	L	B	L1	L2
Vantage 200/510	7080	5070	9400	14300
512	7480	5070	9800	15600
610	7080	5350	9400	14300
612	7480	5350	9800	15600
710	7080	5780	9400	14300
714	8230	5780	11500	17780

L (with transport belt)
L2 (Concept 3 with lifting table and belt)

Vector speed	m/min	(X - Y) 130 - (Z) 20
Compressed air connection	inch	R ½
Compressed air required	bar	7
Dust extraction port	mm	Ø 200
Dust extraction volume	m ³ /h	min. 3170
Total machine weight 510-714	kg	appr. 5100 - 7300
Electrical power – total connection load	kW	26,5 - 38
Switch cabinet	mm	1000/800 x 800 x 1970

VANTAGE 200 SERIES – WORKING FIELDS							
	Width (mm)	Length (mm)	Thickness (mm)	Width (ft)	Length (ft)	Thickness (inch)	Vacuum capacity
Vantage 200/ 510	1550	3130	100	5	10	3,94	580/690 m ³ /h 50/60 Hz
512	1550	3700	100	5	12	3,94	580/690 m ³ /h 50/60 Hz
610	1880	3130	100	6	10	3,94	580/690 m ³ /h 50/60 Hz
612	1880	3700	100	6	12	3,94	580/690 m ³ /h 50/60 Hz
710	2250	3130	100	7	10	3,94	870/1035 m ³ /h 50/60 Hz
714	2250	4300	100	7	14	3,94	870/1035 m ³ /h 50/60 Hz

HOMAG Bohrsysteme GmbH

Benzstrasse 10-16
33442 Herzebrock-Clarholz
Germany
Tel. +49 5245 445-0
info-herzebrock@homag.com
www.homag.com



BLUECOMPETENCE

Alliance Member

Partner of the Engineering Industry
Sustainability Initiative



**Choose the Original
Choose Success!**

For the Success of Original
Technology. A campaign of
the VDMA