

**Flexible.  
Precise.  
Unique.**

**HC HOMAG**

**Our edge banding machines**  
EDGETEQ S-300

**YOUR SOLUTION**





## Perfect edges for discerning customers manufactured with flexible machines

Individual customer needs and preferences, sophisticated products and a wide range of materials – all factors which play a major role in today's woodworking industry. Here, production flexibility and efficiency are key – particularly for woodworking shops and medium-sized enterprises.

HOMAG offers unbeatable benefits and has a presence on the ground with international production plants and sales and service companies with around 6,600 staff members in over 100 countries around the world. Work with HOMAG to create a sharp competitive edge and security for your business in the long term.

We are:

### YOUR SOLUTION

[MORE: HOMAG.COM](https://www.homag.com)



## Content

- 04 All inclusive as standard
- 06 Edge parameters
- 08 Models 1400 airTec, Highflex
- 12 powerTouch control system
- 13 Our unit modules
- 28 Technical data
- 32 LOOPTEQ return conveyor
- 34 Life Cycle Services

## All inclusive as standard

**THE MOST IMPORTANT FEATURES OF THE 8 MODELS.** These series are characterized by its comprehensive equipment standard: Belt-type top pressure for precision workpiece guidance, optimized trimming tools for optimum chip disposal and perfect processing quality. Variable feed speed in various performance categories for high productivity. All machines can also be extended. HOMAG machines EDGETEQ S-300 are energy-saving and environmentally friendly.

- **High-grade furniture with high edge quality**
- **More output through high availability**
- **Low energy requirement**
- **Outstanding economy**
- **Optimum cost-to-performance ratio**



### **Gluing units – safe hot-melt glue application**

HOMAG gluing units are qualified for quick, friction-locked gluing. The heated glue roller provides an optimum glue temperature.

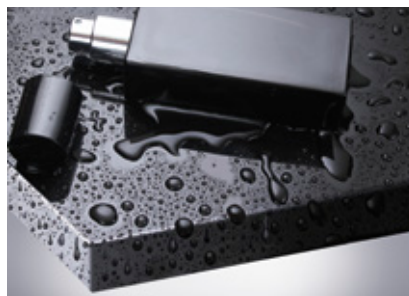

### **Edge banding with PUR**

PUR adhesives are used by HOMAG on the same machines and with the same application units as EVA hot melt adhesives.

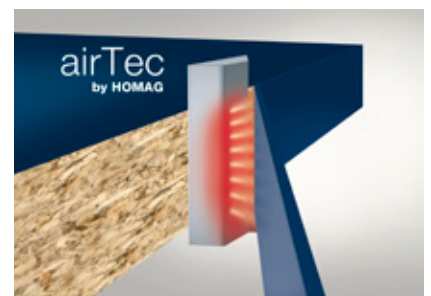

### **Zero joint technology with HOMAG airTec**

The units are now equipped with a rotary air heater which makes the process significantly more efficient and quieter as well as saving resources.



**Intuitive operation with powerTouch control system**

Using the widescreen format multitouch monitor, you control machine functions by direct touch contact. The ergonomically optimized design and an array of help and assistant functions substantially simplify operation.



**Multi-stage technology**

For easy profile change by push button. Saves time and improves quality.

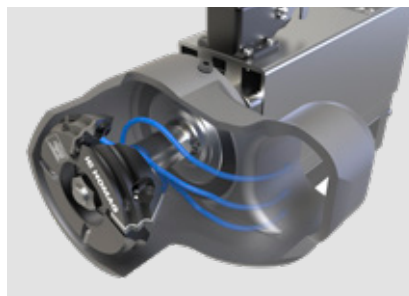

**Controlled chip capture**

The chips are extracted already in the interior and selectively directed to the extraction hood. Greater economy and a longer service life due to reduced wear and lower service costs. Reduced extraction speed drives down energy consumption and costs.

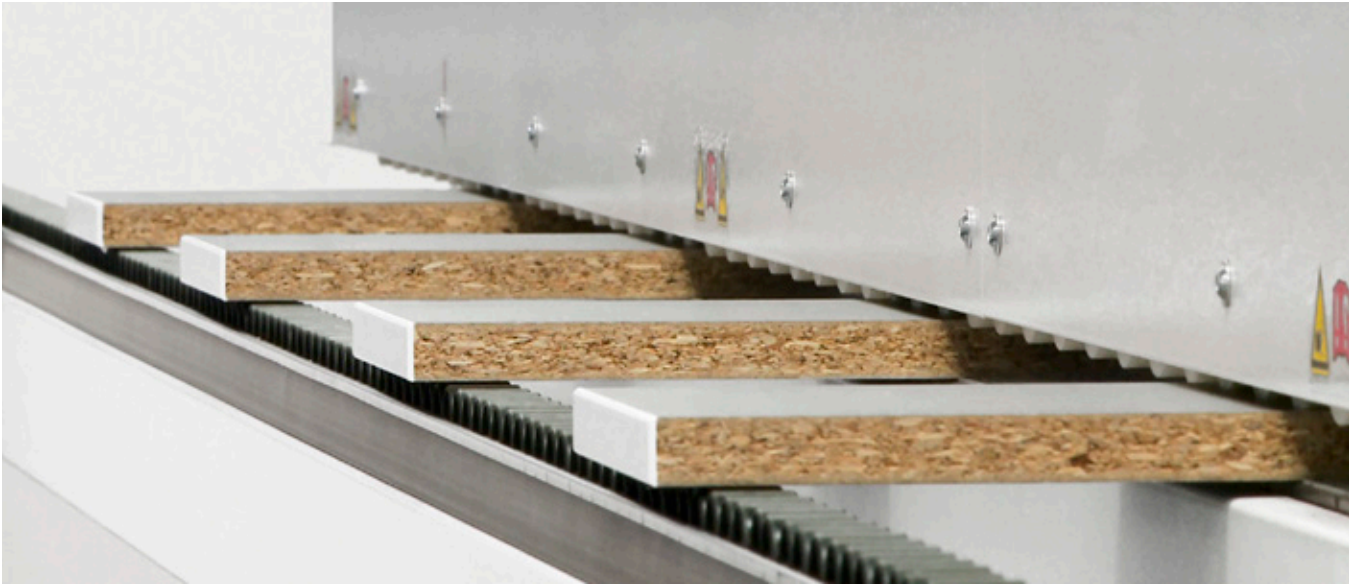

## Material types | Edge parameters

High flexibility is achieved by processing all edge materials: 0.3 mm melamine, 2 mm PVC, 8 mm solid strips and veneer. For perfect high-gloss parts, important components such as the motor-driven top pressure and the automatic adjustment of the glue joint scrapers are used. Special tracing elements are ideal for machining of acute-angled or obtuse-angled parts or parts with hinge holes.

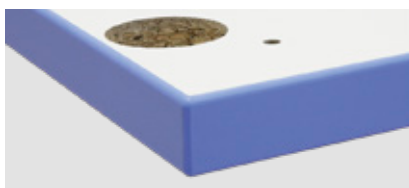

|  |                       |  |                    | a      | b         | c       | d       | e |
|--|-----------------------|--|--------------------|--------|-----------|---------|---------|---|
|  | <b>SOLID</b><br>(mm)  |  |                    |        |           | 0,4 – 8 |         |   |
|  | <b>COILS</b><br>(mm)  |  | with = 22: min. 70 | 8 – 60 | 0,3 – 3,0 | 65      | max. 30 |   |
|  | <b>STRIPS</b><br>(mm) |  |                    |        | 0,4 – 3,0 |         |         |   |

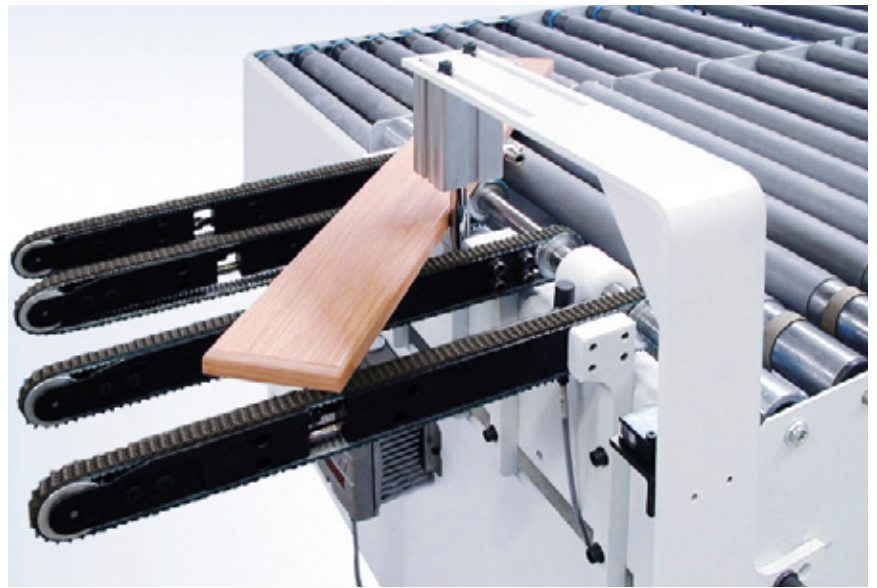

## Higher output for your edge banding machine

Workpiece return conveyors of the LOOPTEQ series are the ideal addition to the machines of the EDGETEQ series. The LOOPTEQ O-300 is ideal for small, narrow and medium-sized workpieces.



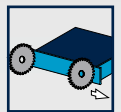

## EDGETEQ S-300 – Model 1440 FC

For woodworking shops and small or medium-sized enterprises, the Model 1440 FC of the EDGETEQ S-300 series secures competitive benefits in the long term. In the basic version, the machine is equipped with a joint trimming unit, a precise gluing unit, a 2-motor snipping unit, a trimming unit, a radius scraper, glue joint scraper and a

buffing unit. Depending on the requirements, the machine can be equipped with a quickmelt gluing unit for even more effective EVA production or a PUR pre-melter. The optionally available machine automation packages reduce set-up times and offer a high level of operating convenience.



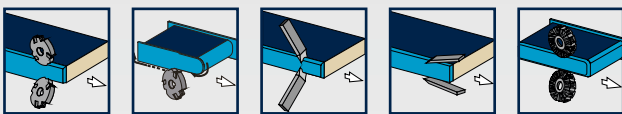
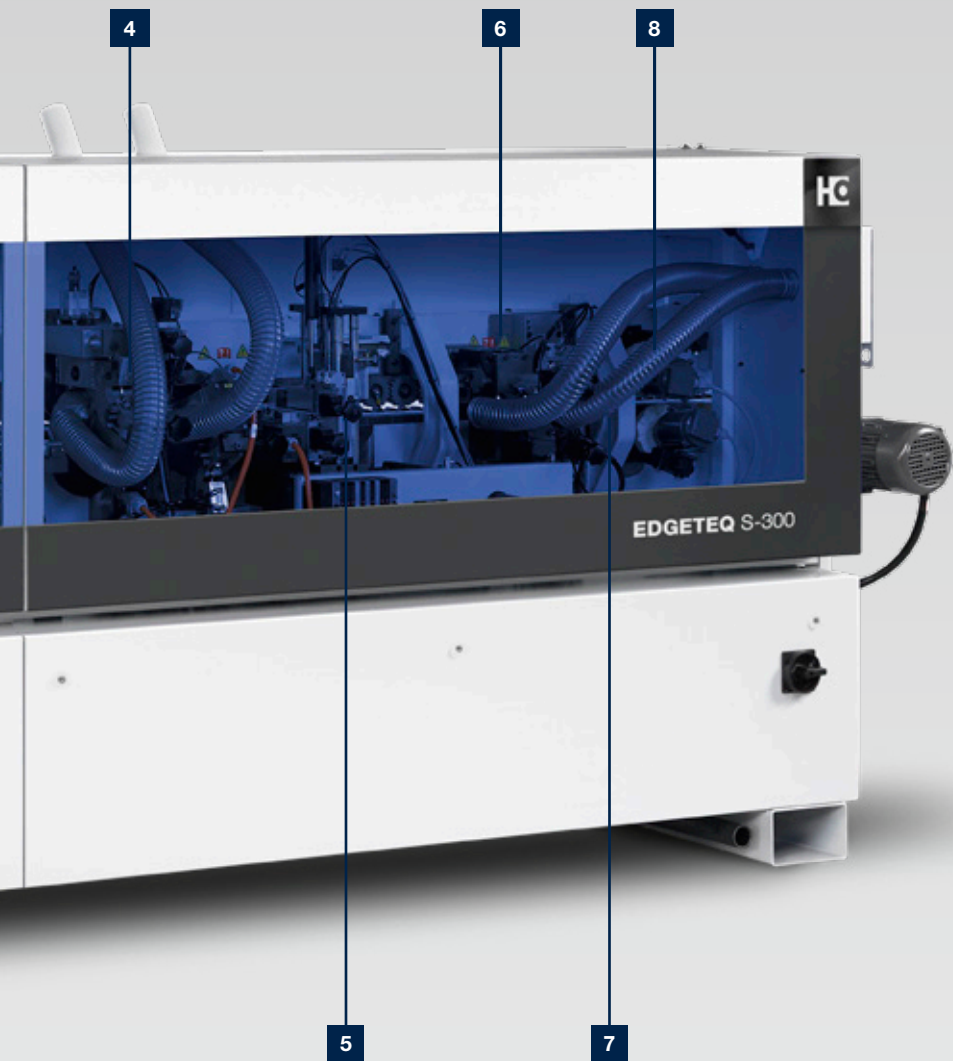

**1** Joint trimming unit

**2** Gluing unit with PUR pre-melter

**3** Snipping unit

**4** Trimming unit

**5** Profile trimming unit

**6** Profile scraper

**7** Glue joint scraper

**8** Buffing unit

## EDGETEQ S-300 – Model 1450 FC

To offer an optimal solution, the basic machine of the 1450 FC model is fitted with a joint trimming unit, a precise gluing station, a dual-motor snipping unit, a trimmer, and a dual-motor profile trimming unit. A profile scraper with quick-change heads, a glue joint scraper, and a buffing unit provide the perfect finish.

If required and on request, the machine can be converted ex factory into an Edition model offering full automation. In

addition to automating the entire machine, the focus here is on postprocessing. The multi-stage technology is used on the trimmer unit and scraper. The radii can be changed easily at the press of a button as the units are fitted with NC axes. This means that the entire machine is equipped with multi-stage technology and the customer is free to change radii in line with the requirements. Full flexibility is guaranteed, and all individual customer requests can be taken into account.



## Model 1430 HF

This machine is equipped with a precise Quickmelt gluing unit, a tiltable two-motor snipping unit for straight and chamfer snipping, as well as a trimming unit. For complete processing, a joint trimming unit, a profile trimming unit, a radius scraper, a glue joint scraper and a buffing unit are available for the perfect finish. The Highflex machines of the EDGETEQ S-300 series are characterized by its high level of automation and a comprehensive range of processing units. The high degree of flexibility enables adjustment to your specific needs and guarantees optimum edges.



## Model 1440 AT

For joiners with high-end requirements, the EDGETEQ S-300 airTec model is the ideal machine. Whether for production of the perfect zero-joint or for other edge processings, the machine always provides the perfect solution.

The nerve center of the machine is the gluing unit, which alongside the airTec activation unit also acts as a dual solution, guaranteeing outstanding flexibility. Alongside the magazine, the machine is equipped with a joint trimming unit, a two-motor snipping unit, a trimming unit and a profile trimming unit. A radius scraper, glue joint scraper and a buffing unit ensure a perfect finish. The airTec models are characterized by their high level of automation and a comprehensive range of processing units.





## powerTouch – The new dimension of machine control units

powerTouch represents the operating philosophy of HOMAG: standardized, easy, ergonomic, and evolutionary. The innovative

touchscreen operating concept combines design and function in a completely new generation of control systems.

At the heart of the concept is a large, widescreen multitouch monitor that allows machine functions to be controlled directly by touch. The entire programming interface is optimized for powerTouch operation and offers numerous new help and assistant functions that make working processes substantially easier. Standardized operating elements and software modules ensure that all HOMAG edge banding machines from EDGETEQ S-300 can be operated in the same way using this new concept. They differ only in a few machines-specific details. This not only simplifies operating different machines, but also makes for greater efficiency by significantly reducing the time spent on training and service.



### Teleservice reduces on-site service visits

- Reduction in service costs
- Avoids unplanned machine downtimes
- Targeted planning for service visits and spare parts delivery
- Support for maintenance and operating personnel

### Your benefits

- **15,6" monitor with full HD resolution**
- **Fast overview of machine status**
- **Easy, user-oriented navigation**
- **Guided path to production readiness through traffic light indicator**
- **New ergonomic design of the operating panel**
- **Intuitive, natural touch operation on the machine**
- **Use of gestures, e.g. scrolling, swiping**

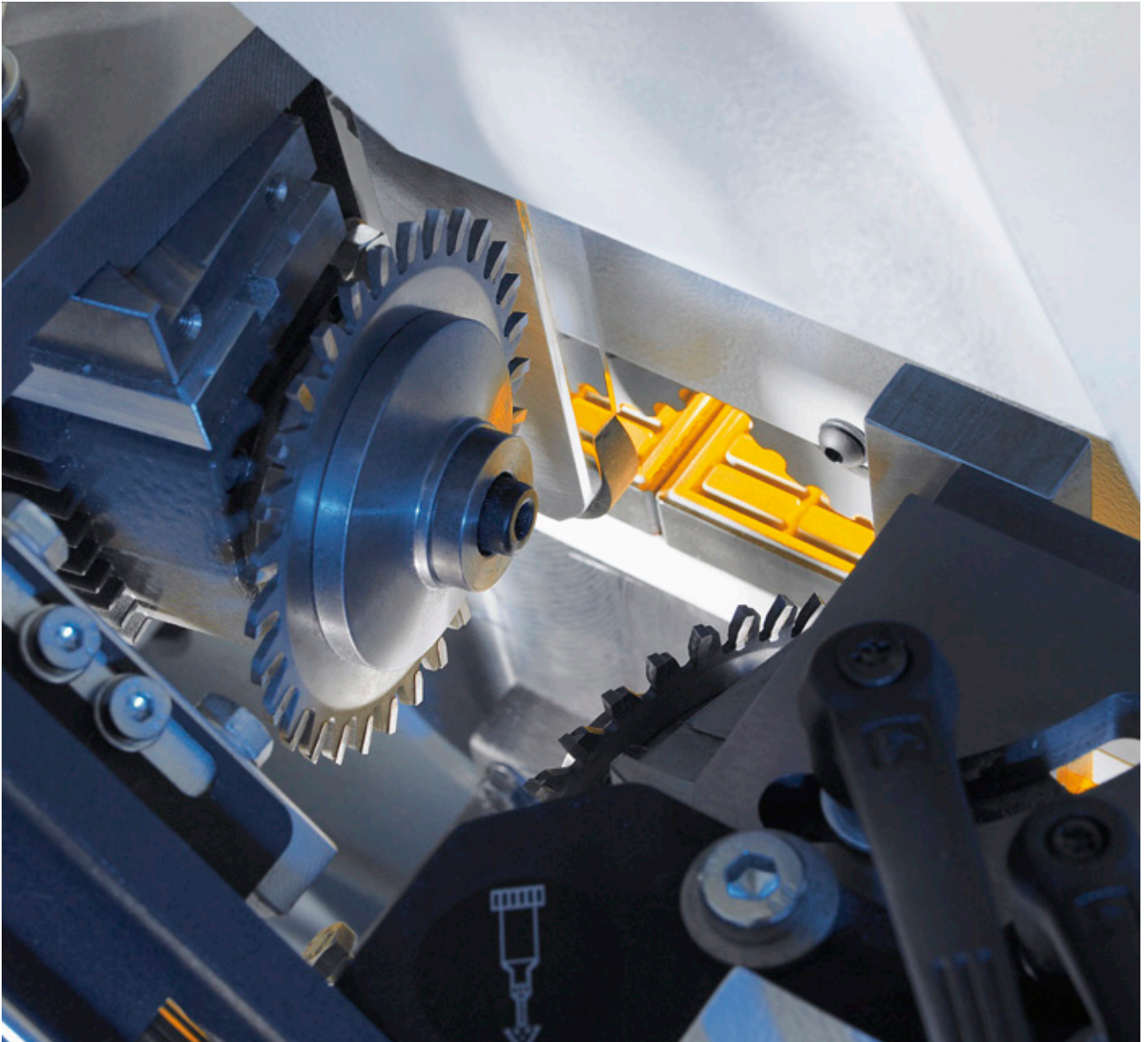

## Our range of modular units: The right solution no matter what the requirement

For wide-ranging different processing tasks, we use units from our tried and tested modular range. By continuously extending the offered functions, we ensure that you have the right solution available to cope with changing trends.

Presenting a range of units for joint trimming, gluing, snipping, profile trimming, grooving and finish processing. Their extreme precision and state-of-the-art technology will boost the flexibility and efficiency of your production.

## Workpiece feeding

Precise workpiece feeding is a pre-condition to achieve perfect edge quality. Our solutions are your benefit: infeed

guide, infeed stop, sliding carriage or workpiece support.

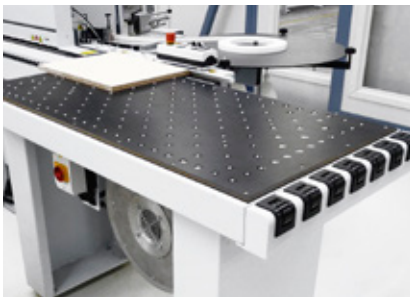

**Air cushion table**  
For easy workpiece feeding.



**Automatic infeed guide adjustment**  
Precise, repeatable program-controlled infeed guide adjustment by means of servo axis.



**Sliding carriage**  
Robust linear guiding system to secure right-angled workpiece feeding.



**Infeed stop**  
For minimum workpiece spacing and safe operation.



**Insertion device**  
Automatic edge infeed for quick edge changes between different rolls of material.



**Belt-type top pressure**  
Belt-type top pressure available as an option instead of the standard roller pressure system

## Spraying units

Spraying units help to improve edge quality throughout the complete processing. Separating agent avoids that hot melt glue residuals adhere to the workpiece and antistatic agent avoids that plastic chips adhere to the workpiece.

Cleaning agent helps to easily remove glue residuals. Lubricant is applied to protect sensitive surfaces before trimming and to prevent gloss marks on the workpieces.

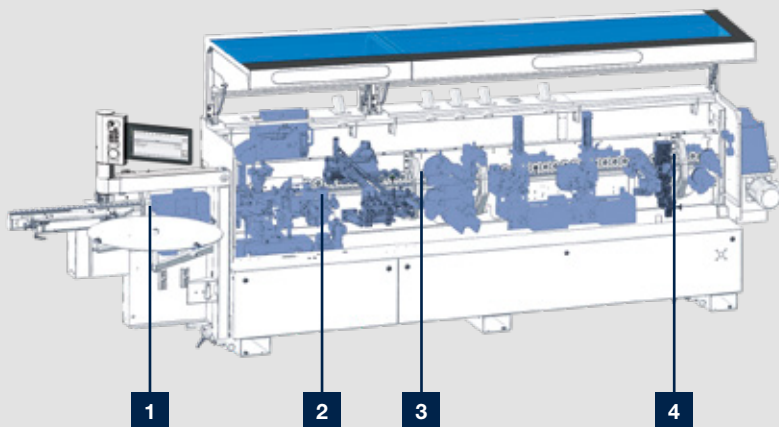

- 1** Separating agent
- 2** Lubricant
- 3** Antistatic agent
- 4** Cleaning agent

## Joint trimming unit

The HOMAG joint trimming units provide the perfect basis for splinter-free workpiece edges and glue joints with a consistently high standard of product quality.

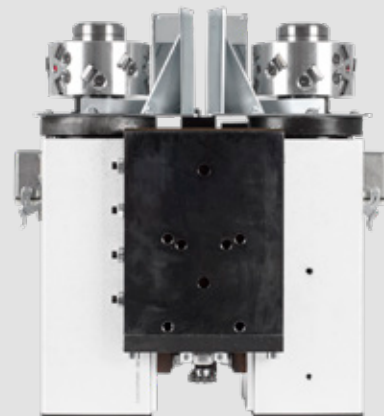

### Joint trimming unit

Perfect cut and long service life due to diamond tipped tools for optimum edge joint quality. The diameter is 100 mm.



## Gluing units – reliable hot melt glue application

HOMAG gluing units are ideal for a fast, positive-locking glue bond. The heated glue roller ensures an optimum gluing temperature. On request, the gluing unit can also be

individually equipped with a PUR pre-melting unit – allowing rapid changeover between two different colors or PUR.

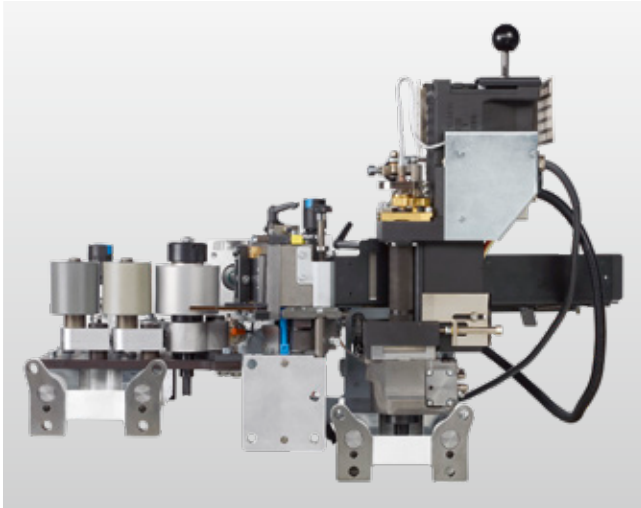

### QA65N glue application system – gravity fed

The application unit can be easily removed by means of a quick-change device with pneumatic interface.

### Your benefits at a glance - QA65N

- Short heating-up time by sensed level control (2 levels selectable)
- The application unit can be easily removed by means of a quick-release lock for melting hot-melt glue either automatically or manually
- Glue roller with integrated heating guarantees constant temperature and viscosity for all workpiece thicknesses
- Electropneumatic glue roller and tank clamping prevents glue soiling on the trailing edge of the workpiece
- Tracing pad prevents wear of the application roller and ensures a consistent glue film thickness
- Glue roller lift-off on feed stop

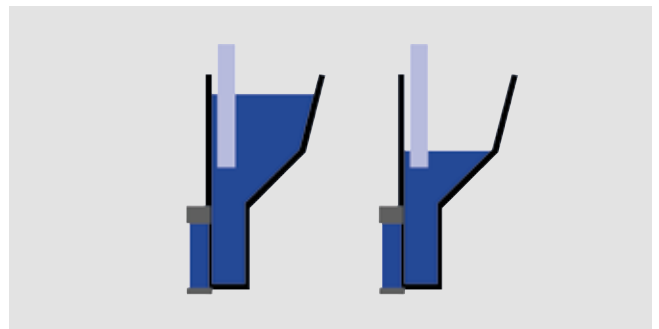
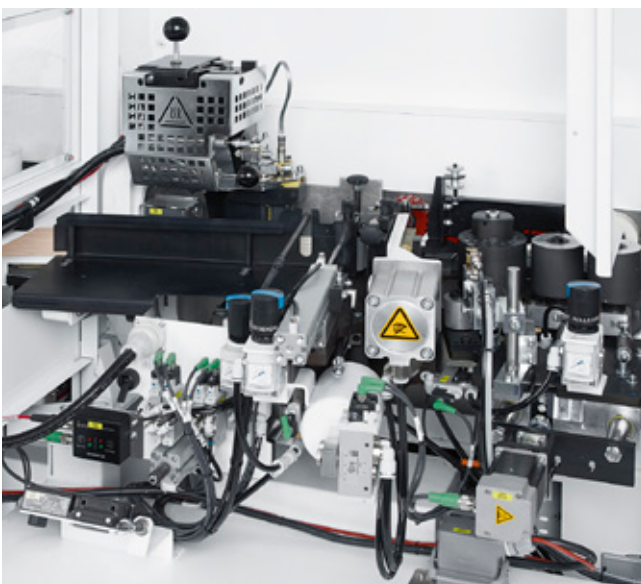

### Sensor for checking the fill level of the application unit

Switching to a lower glue level guarantees a fast heat-up time for processing small batch sizes.





## Systematic gluing

Achieving perfect gluing results depends on the optimum interaction of entirely different factors. The workpiece pre-heating, the application unit, quick clamping system, melting

unit, magazine and pressure zone from HOMAG are all designed for optimum coordination.



### Workpiece pre-heating with heaters

High-strength gluing due to optimum workpiece pre-heating.

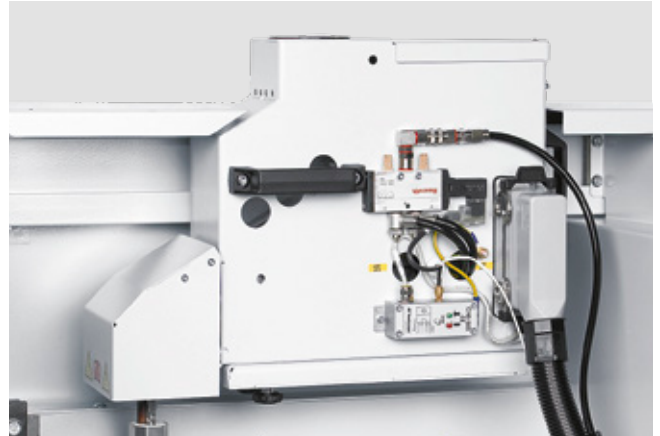

### Pre-melting unit (optional)

High degree of availability and optimum gluing quality thanks to the quick-melt gluing station.



### Pressure zone

Heavy pressure zone up to an edge thickness of 8 mm and a panel height of 60 mm for optimum glue joint quality.



### Roller counter pressure

Roller counter pressure for sensitive edge material.

## PUR glue and HOMAG – a strong alliance

The moisture and heat resistance of furniture is increased by the use of polyurethane (PUR) hot melt glue. Its use is ideal for furniture in damp areas such as bathrooms, kitchens and labs.



### **YOUR HOMAG PUR BENEFITS AT A GLANCE**

- One application unit for all glue types
- No additional application unit needed
- Quick, friction-locked thin film application by glue roll with integrated heater
- Can be used by the entry-level model to highend machine as standard



**PUR pre-melting unit**

- Melting output 2.5 kg/h
- Temperature control to prevent overheating



**Vacuum tank**

- Compact, mobile tank for storing the PUR application unit
- No vacuum pump and no nitrogen required



**Service station**

- Pre-heating and cleaning station for the application unit QA65N with a storage area
- High flexibility through the use of 2 vacuum containers, each for one QA65N application unit or a PUR pre-melting unit 2.5 kg/h
- No vacuum pump and no nitrogen required

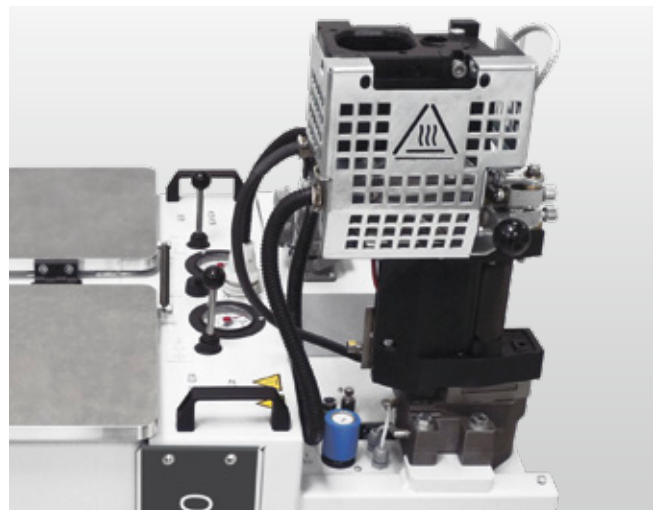

**Service station**

- Picture shows application unit in holding device for preheating

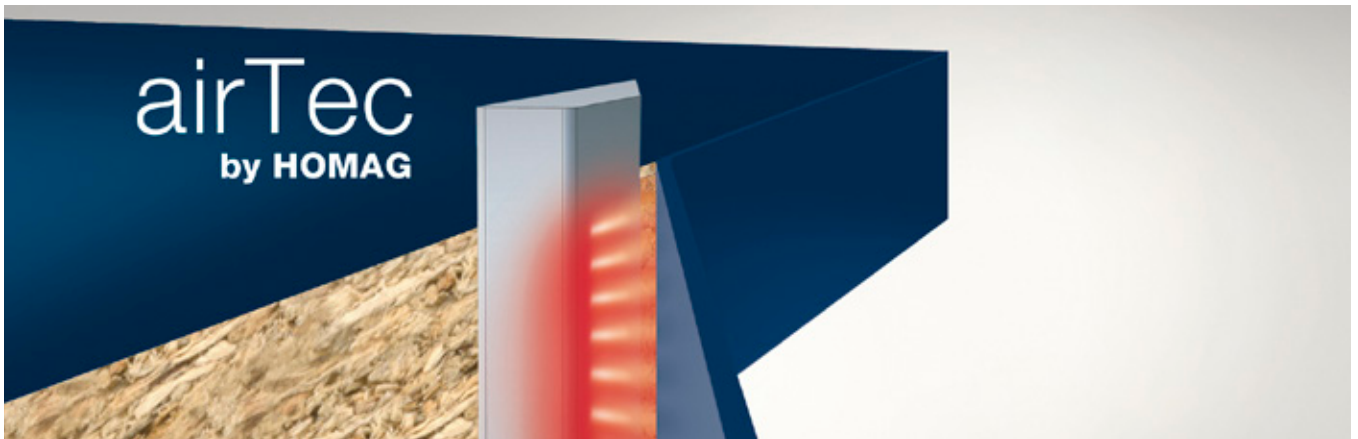

## airTec – the ideal entry into zero joint technology

The airTec process has become an established zero joint solution in woodworking shops and SMEs. HOMAG's answer to the growing demand is an innovative, more efficient and resource-saving airTec solution. The nerve center of the airTec unit is a rotation air heater which not only enhances

efficiency but also operates with significantly lower noise emissions. airTec can be used to process all types of currently popular, laser-suitable edging types. This means great flexibility for all materials and colors.



### Edge banding “without joints”

The airTec method bonds the edging to the panel using hot air. This requires the use of special edges. These comprise a decor layer and a function layer. The HOMAG airTec unit melts the function layer at an even temperature and flow rate and bonds it perfectly to the narrow surface.

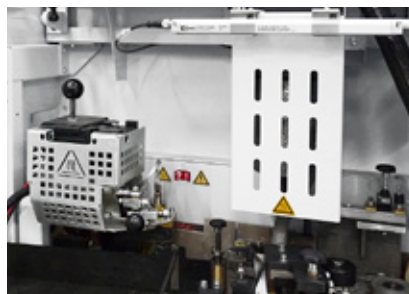

### Easy integration

The airTech reactivation unit is installed in such a way that it is possible to work with either the standard application unit or the airTech system.

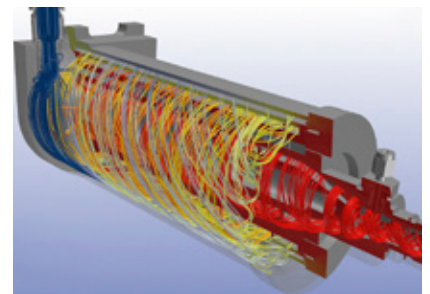

### Innovative rotation air heater

The source of energy heats the air while at the same time acting as a heat store for subsequent repeated air heating. In addition, less air is required and the heating effect on the surrounding area is minimized. Any noise is almost exclusively produced during the activation process and is below the noise level of other processing units.

## Snipping units for cutting the face side overhang

The snipping units prepare the workpieces perfectly for subsequent trimming operation. The face side can be

snipped either straight or with chamfer.

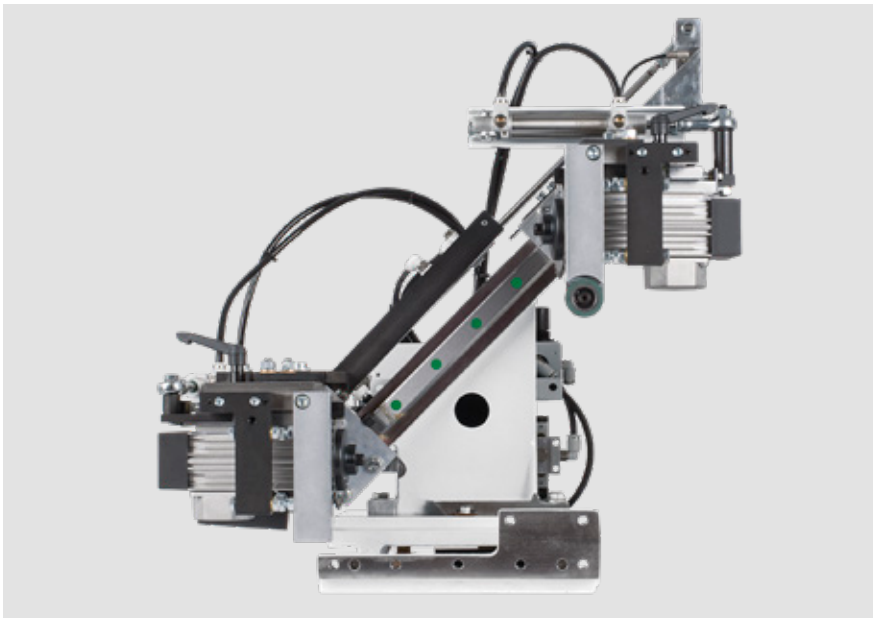

### Snipping unit

Exact snipping cut using a robust snipping unit with a highly precise linear guide. Swivels to easily adjust for chamfer or straight snipping (optional: adjustment using pneumatics).

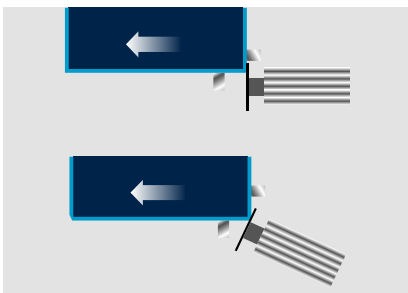
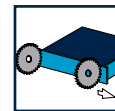

### Automation as standard

Programmable chamfer/straight snipping motor adjustment for fast changeover between straight snipping and snipping with chamfer.

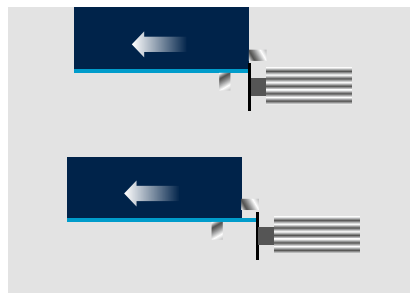

### Automation to suit every need

For fast changeover between flush snipping (e.g. of solid strips or inlay shelves) and snipping with overhang (e.g. for finish trimming with profile trimming unit).

## Trimming units for flush trimming

The rough trimming and fine trimming units offer the perfect solutions for processing edge overhangs.

The trimming units are equipped exclusively with tools capable of controlled chip capture.

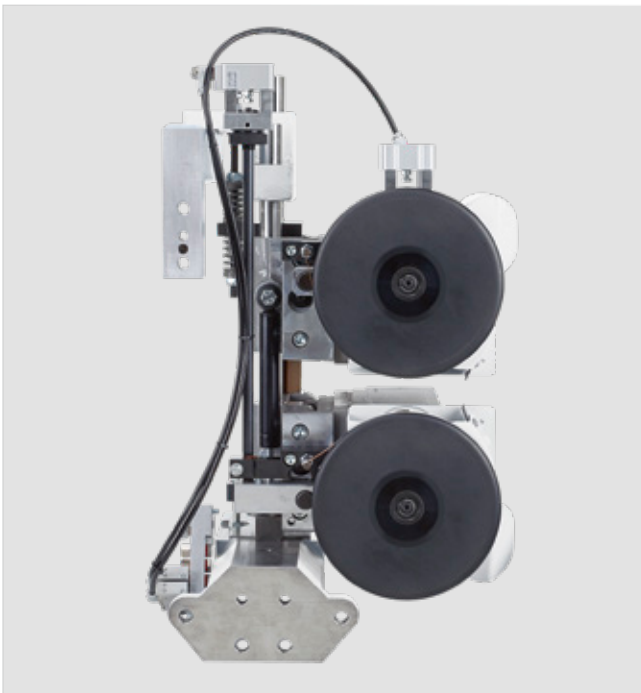

### Rough trimming unit

For rough trimming of all common edge banding materials.



### Trimming unit

Flexibility for different edge thicknesses and profiles thanks to NC axes.

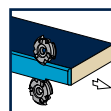
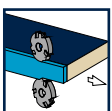

## Trimming with multi-stage technology

The range of edges and panel materials is continually growing and so is the demand for flexibility. It is immaterial if edges are made from plastic, solid wood or veneer, or if workpieces have high-gloss surfaces.

The multi-stage trimming unit always offers the optimum radius for frequently changing applications, and therefore the best results.



### Multi-stage trimming unit MS40/45

Fully automatic changeover to three different profiles using servo motors\*.

Image shows nesting package.\*

\* Servo motors: Servo drives consist of motors with a stepless adjustment. They impress thanks to a high positioning accuracy and are particularly suitable for small positioning distances.

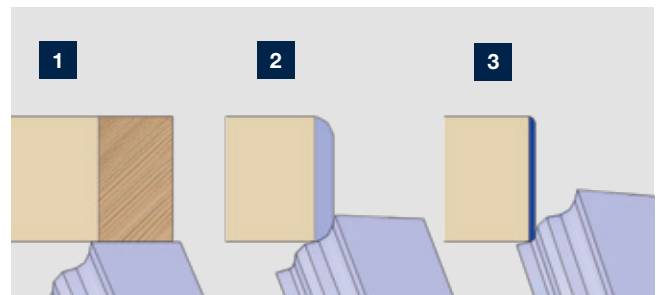

**1** Plan (MS 40/45)

**2** Profil 1

**3** Profil 2

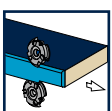

# Profile trimming units

The profile trimming units are universal. The user has the choice to adjust the units manually or to control them via program.

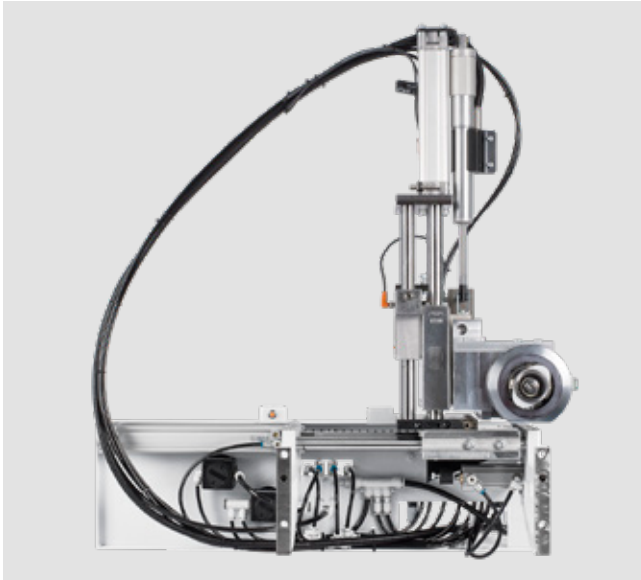

### Profile trimming unit FF10

Optimum profile trimming without making adjustments thanks to linked DIA tool and tracing roller. Equipped with an automatic adjustment to switch between thin and thick edges. Workpiece thickness up to 60 mm.

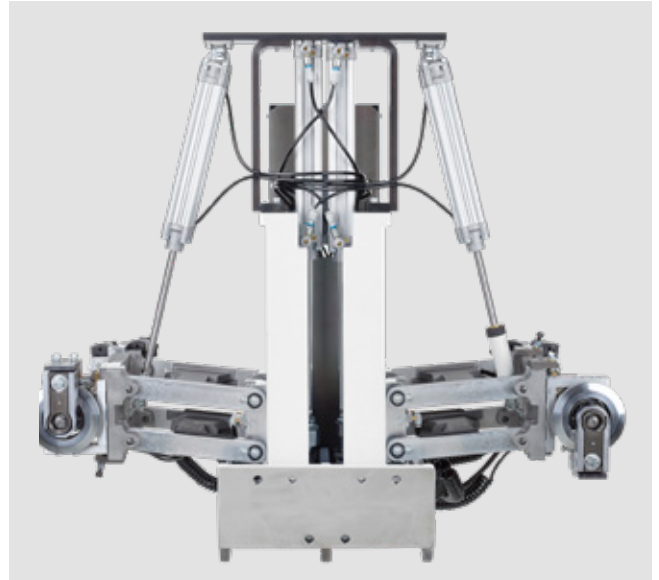
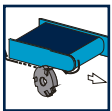

### Profile trimming unit FF20

For rounding corners on thick PVC edges, as well as top edges on post-forming and soft-forming parts. Equipped with an automatic adjustment to switch between thin and thick edges. Workpiece thickness up to 60 mm.

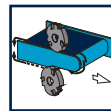

### Multifunctional trimming unit MF50

Trimming of the top and bottom edge overhang as well as corner copying on the front and rear edges. Equipped with an automatic adjustment to switch between thin and thick edges. Workpiece thickness up to 60 mm.

### Automation to suit every need

Automatic adjustment between two different radii is possible.

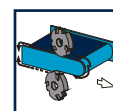





## Grooving unit

A swiveling grooving unit is available for grooving. If required, the workpiece underside and the front side can be grooved.

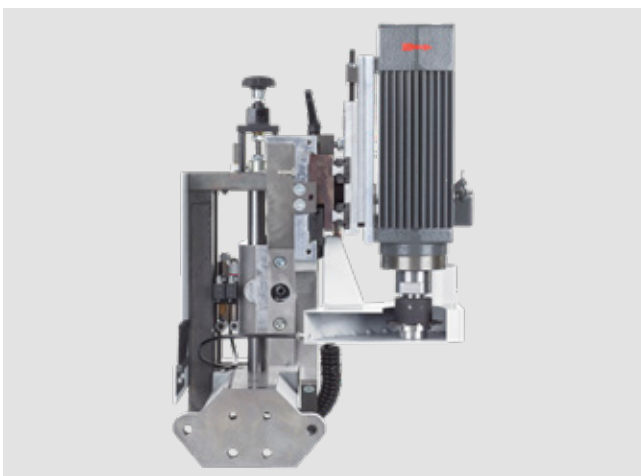

### Grooving unit

A swiveling grooving unit is available for grooving. If required, the workpiece underside and the front side can be grooved with EDGETEQ S-300 Model 1440 FGC.



### Safety device

for grooving solid strips in synchronous rotation.

## Finishing units

HOMAG ensures the optimum quality of your products with a range of ideally coordinated finishing units.



### Profile scraper

Unit to smooth radii or chamfers, equipped with quick change heads for fast profile change.

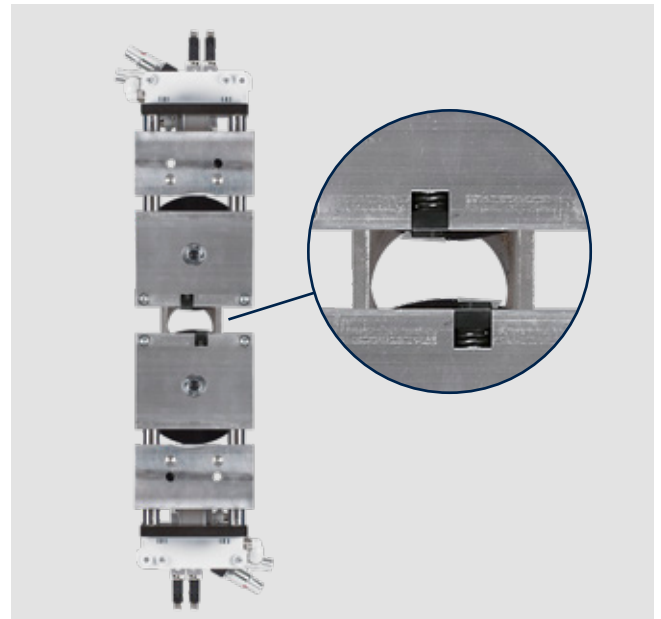
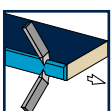

### Glue joint scraper

For the perfect finish.

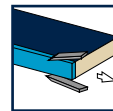

### Buffing unit

To polish edges and maintain their natural color.

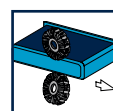

## Finish with multi-stage technology

The range of edges and panel materials is continually growing and so is the demand for flexibility. It is immaterial if edges are made from plastic, solid wood or veneer, or if workpieces have high-gloss surfaces.

The multi-stage scraper always offers the optimum radius for frequently changing applications, and therefore the best results.

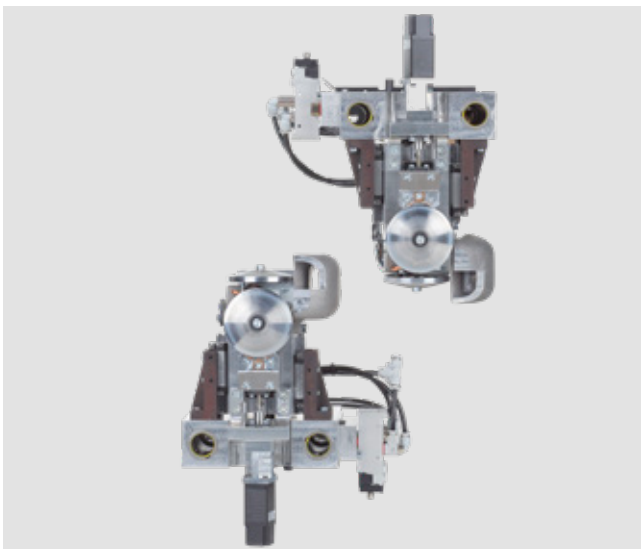

### Multi-stage scraper MZ40

Fully automatic changeover to two different profiles using servo motors\*.

\* Servo motors: Servo drives consist of motors with a stepless adjustment. They impress thanks to a high positioning accuracy and are particularly suitable for small positioning distances.

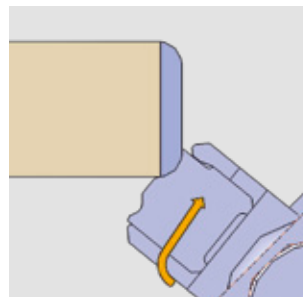

Profile 1

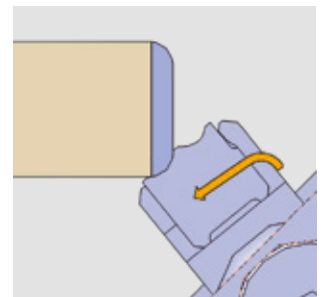

Profile 2

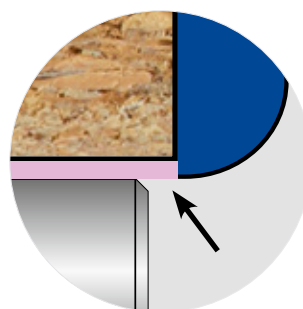

Optimum compensation for protective films

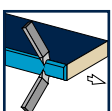

**TECHNICAL DATA FOR EDGETEQ S-300 SERIES**

|   | Model 1430 FC | Model 1440 FC | Model 1440 FGC | Model 1450 FC | Model 1450 FCG |
|---|---------------|---------------|----------------|---------------|----------------|
| <b>Overall length (mm)</b>                        | 4,773         | 5,273         | 5,273          | 5,773         | 5,773          |
| <b>Feed speed (m/min)</b>                         | 8 – 14        | 8 – 14        | 8 – 14         | 8 – 14        | 8 – 14         |
| <b>WORKING DIMENSIONS</b>                         |               |               |                |               |                |
| <b>Workpiece width (mm)*</b>                      |               |               |                |               |                |
| with workpiece thickness 8 – 22 mm                | 70            | 70            | 70             | 70            | 70             |
| <b>Workpiece thickness (mm)</b>                   | 8 – 60        | 8 – 60        | 8 – 60         | 8 – 60        | 8 – 60         |
| <b>Edge thickness, coils (mm)</b>                 | 0.3 – 3       | 0.3 – 3       | 0.3 – 3        | 0.3 – 3       | 0.3 – 3        |
| <b>Edge thickness, strips / solid strips (mm)</b> | 0.4 – 8       | 0.4 – 8       | 0.4 – 8        | 0.4 – 8       | 0.4 – 8        |

\* dependent on the workpiece thickness

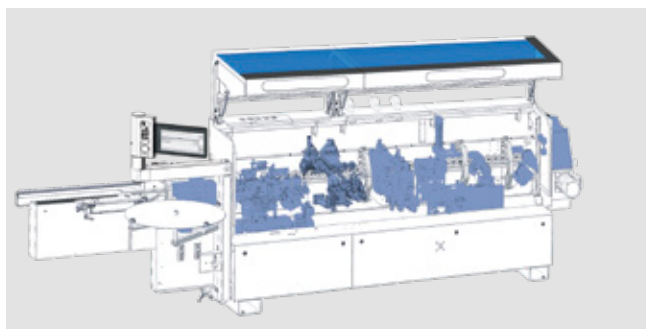

**Model 1430 FC**

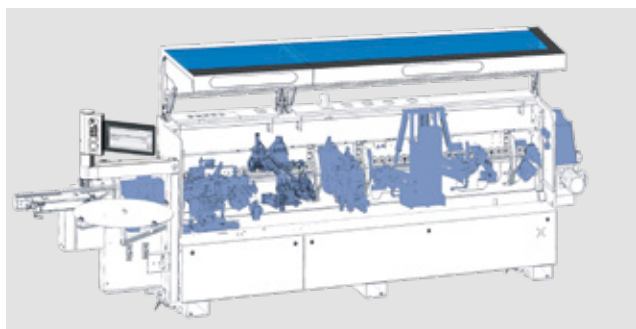

**Model 1440 FC**

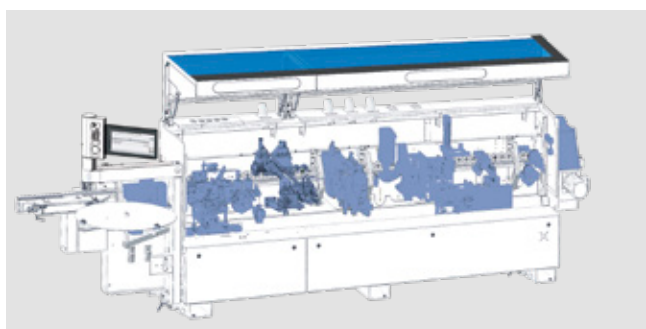

**Model 1440 FGC**

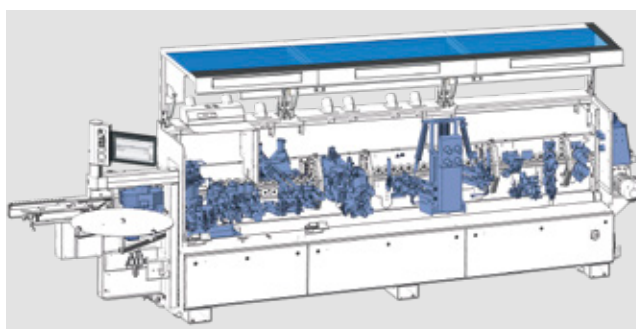

**Model 1450 FC**

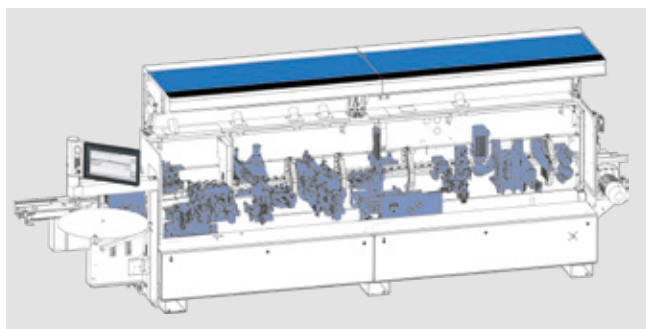

**Model 1450 FGC**

**TECHNICAL DATA FOR EDGETEQ S-300 SERIES**

|   | Model 1430 HF | Model 1440 HF | Model 1440 E | Model 1440 AT |
|---|---------------|---------------|--------------|---------------|
| <b>Overall length (mm)</b>                        | 4,773         | 5,273         | 5,573        | 5,573         |
| <b>Feed speed (m/min)</b>                         | 8 – 14        | 8 – 14        | 8 – 14       | 8 – 14        |
| <b>WORKING DIMENSIONS</b>                         |               |               |              |               |
| <b>Workpiece width (mm)*</b>                      |               |               |              |               |
| with workpiece thickness 8 – 22 mm                | 70            | 70            | 70           | 70            |
| <b>Workpiece thickness (mm)</b>                   | 8 – 60        | 8 – 60        | 8 – 60       | 8 – 60        |
| <b>Edge thickness, coils (mm)</b>                 | 0.3 – 3       | 0.3 – 3       | 0.3 – 3      | 0.3 – 3       |
| <b>Edge thickness, strips / solid strips (mm)</b> | 0.4 – 8       | 0.4 – 8       | 0.4 – 8      | 0.4 – 8       |

\* dependent on the workpiece thickness

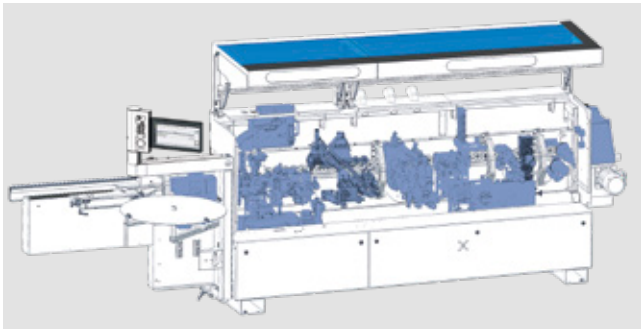

**Model 1430 HF**

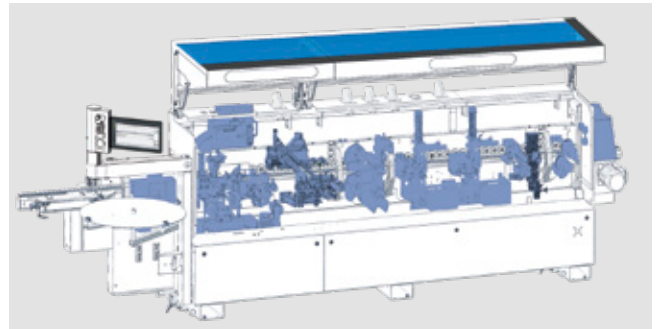

**Model 1440 HF**

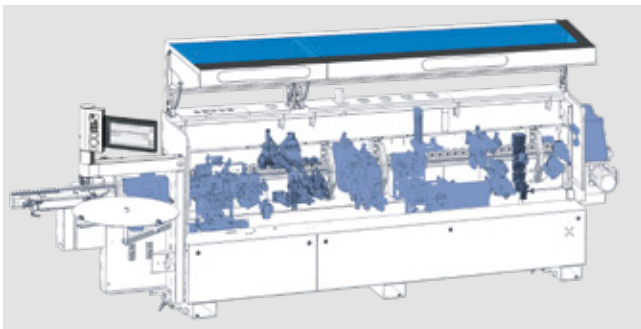

**Model 1440 E**

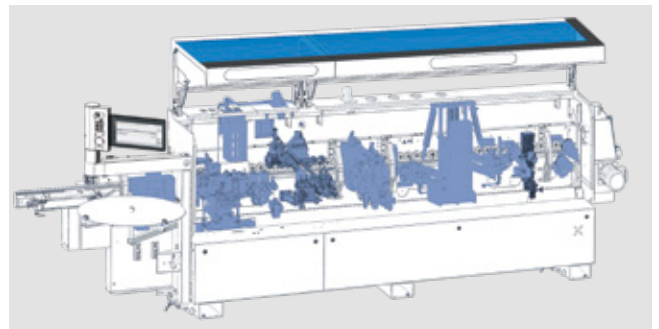

**Model 1440 AT**



# The right machine for your requirements

The machines from the EDGETEQ S-300 series offer comprehensive solutions for the flexible and economical manufacture of your products. Whether living room, bedroom and kitchen furniture, functional office furniture, superior shopfitting solutions or batch size 1 production for

individual requirements — HOMAG offers a well designed product range to meet any requirement. Using these machines can also make current trends easily achievable for you and your employees.





## LOOPTEQ O-200 return conveyor: Higher productivity for your HOMAG edge bander

As an indispensable assistant the return system renders your HOMAG EDGETEQ even more economic. With the one-man-operation you optimize the workpiece return and allow a lean and efficient production process. Any combination of your

HOMAG machine of the EDGETEQ S-300 series with this return system is provided. Ideally suited for customers with small, narrow, and medium-sized workpieces.

### LOOPTEQ O-200

The entry to a comfortable material flow.

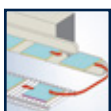

### YOUR BENEFITS AT A GLANCE

- **Fast amortization – pays off from 9 hours working time per week**
- **Flexible operator organization – thanks to economic one-man operation**
- **Ergonomic working – manual parts handling is reduced to a minimum**
- **Improved quality control – rapid response to material adjustments**



| TECHNICAL DATA                            |               |
|---|---------------|
| LOOPTEQ O-200                             |               |
| Workpiece length (mm)                     | 300 – 2,500   |
| Workpiece width (mm)                      | 50 – 1,450    |
| Workpiece thickness (mm)                  | 8 – 60        |
| <b>4-SIDED PROCESSING*</b>                |               |
| min. workpiece length (mm)                | 300 x 300     |
| max. workpiece length (mm)                | 1,450 x 1,450 |
| <b>MISCELLANEOUS</b>                      |               |
| Workpiece weight (kg)                     |               |
| Feed speed (m/min.)                       | max. 30       |
| at length > 700 mm                        | max. 50       |
| Feed speed (m/min)                        | 8 - 25        |
| Mass per unit area (kg / m <sup>2</sup> ) | 25            |

\*Larger workpieces can be returned or fed out at 4-sided processing with manual assistance during crosswise offset and turning.

## By the way

The return conveyor already pays off within one year, in fact starting from an operation of 9 hours per week!



### Sensor-controlled pivot pins (option)

For easier rotation of short and narrow workpieces.

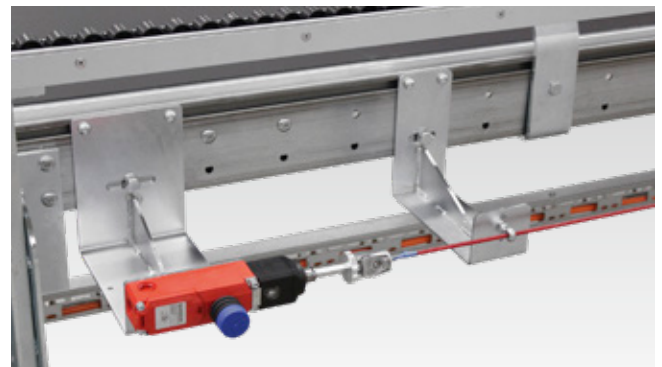

### CE Package

Safety engineering equipment. For the protection of the employees.

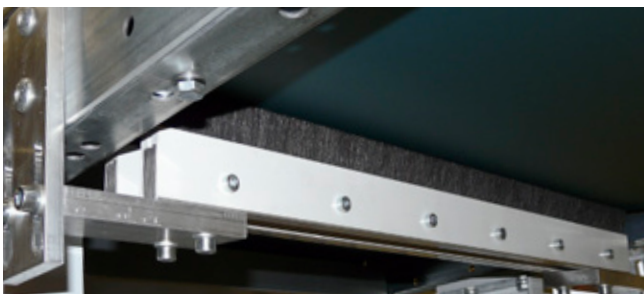

### Belt cleaning

For optimal protection against dust and chips.



### Remote control

Separate control panel at the infeed of the edge-banding machine.

# HC LIFE CYCLE SERVICES

Optimal service and individual consultations are included in the purchase of our machines. We support you with service innovations and products which are especially tailored to your requirements. With short response times and fast

customer solutions we guarantee consistently high availability and economical production – over the entire life cycle of your machine.



## REMOTE SERVICE

- Hotline support via remote diagnosis by our trained experts regarding control, mechanics and process technology. Thus, more than 92% less on-site service required and consequently a faster solution for you!
- The ServiceBoard App helps to solve tasks in a fast, simple and concrete way. This is achieved by mobile live video diagnosis, automatic sending of service requests or the online spare parts catalog eParts.



## SPARE PARTS SERVICE

- High spare parts availability and fast delivery.
- Ensuring quality by predefined spare parts and wear parts kits, comprising original spare parts.
- Identify and inquire for spare parts online under [www.eParts.de](http://www.eParts.de) 24/7, or buy even faster and more comfortably in the new HOMAG eShop ([shop.homag.com](http://shop.homag.com)).



## MODERNIZATION

- Keep your machinery up to date and increase your productivity as well as your product quality. This is how you can meet tomorrow's requirements today!
- We support you with upgrades, modernization as well as individual consultancy and developments.



## DIGITAL SERVICES

- serviceRemote – the new remote service solution of the future! Fast restart of production because the remote service employee has extensive access to relevant physical data.
- serviceAssist – provides help for self-help. The preventive solutions proposed in the new App are the combination of our experiences and existing machine data.



## SOFTWARE

- Telephone support and consultancy through software support.
- Digitalization of your spare parts via 3D scanning saves time and money compared to new programming.
- Subsequent networking of your machinery with intelligent software solutions ranging from construction to production.



## FIELD SERVICE

- Increased machine availability and product quality by certified service staff.
- Regular checks through maintenance / inspection guarantee the highest quality of your products.
- We offer you the highest availability of technicians in order to reduce downtimes in case of unpredictable troubles.

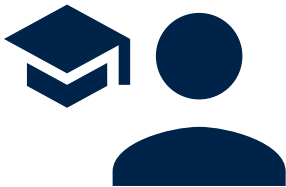

#### TRAINING

- Thanks to training perfectly suited to your requirements, your machine operators can optimally operate and maintain the HOMAG machines.
- The training also includes customer-specific training documents with exercises proven in practice.
- Online training and webinars. Learn without traveling, meet your trainer in the digital classroom.

For you more than...

**1,350**

service employees worldwide

**92%**

less on-site service thanks to successful remote diagnosis

**5,000**

customers in trainings / year

**150,000**

machines, all electronically documented in 28 different languages – in eParts

## **HOMAG Group AG**

info@homag.com

www.homag.com



## **YOUR SOLUTION**