

Panel Saw Series



Designed with heavy-duty performance, advanced concepts, precision and reliability in mind, the sliding panel saw series from HOLYTEK, will provide extraordinary benefits. Each machine is ruggedly constructed to ensure maximum rigidity and stability. Also, the advanced design of the carriage guarantees the best dimensional accuracy and finish.

P-3200TA

HOLYTEK

P-3200TA 3X

Heavy-duty, Reliable and with Maximum Rigidity



Safety Bar
The optional safety bar prevents operator injuries if the rip fence and sliding table are performing abnormally.



Auto. Rip Fence
It features motor drive for fast and smooth movement as well as highly accurate positioning utilizing a CNC controller.



Sliding Table
The multi-chamber sliding table is manufactured by a highly reputed European aluminum company. It also features a built-in wheel-type sliding mechanism. The rail is manufactured from high-tensile steel, heat treated and the surface is chrome plated for lifetime straightness.

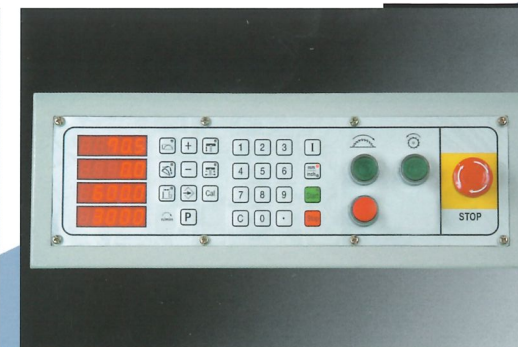
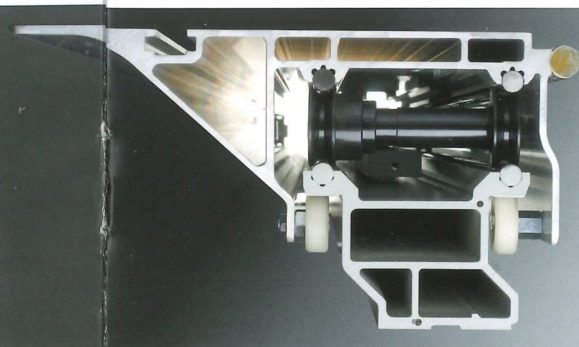

CNC Control Panel
The standard fixed or optional hanging-type controls can be used for setting the saw blade up or down, tilting and cutting width dimensions. Also, there is a 30-set of program memory capacity.



P-3200TA

Advanced Concepts, Stability and High Performance.

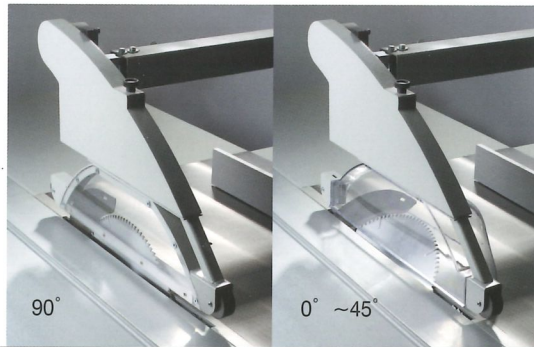

Saw Guards

There are two saw guards - 0° ~ 45° and 90° which feature easy replacement. Up and down adjustment is achieved by simply raising or pressing down - without the need for any tools. (For CE standard only)

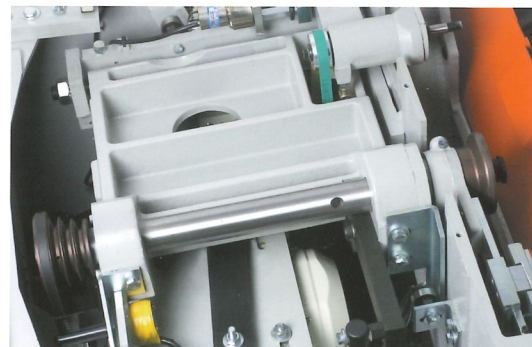

Main Blade Saw

The main saw spindle is a major axes type with every axis having been tested for perfect balance. The rotational speed can be: 3,000 / 4,000 / 5,000 or 6,000 RPM.



Cross Cut Digital Display Stop (optional)

The cutting size can be read directly on the digital display which features micro measurement for accurate positioning. Maximum cutting length of 3,000 mm is available.

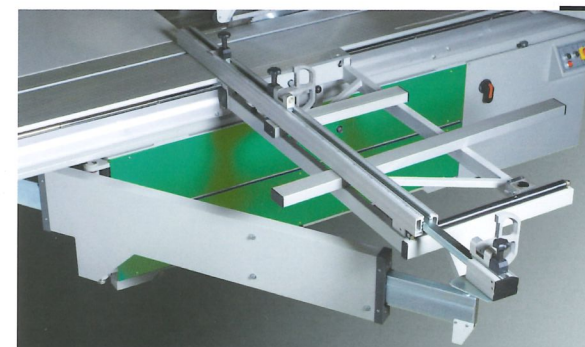

Rigid Cross Cut Table

The rigid steel structure of the cross cut table can be quickly locked to any section of the sliding table.

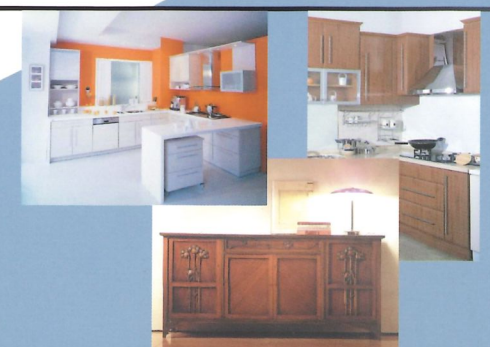

P-3200TM

Precision, Rugged Construction and Perfect Dimensional Accuracy



Digital Readout Display

Saw blade tilt angle as well as RPM are displayed on the panel.



Hand Wheel Adjustment

The main blade up, down and tilting adjustment is accomplished by the cast-iron hand wheels which are conveniently located at the front of the machine. The optional digital display of the angle can be applied for greater accuracy.

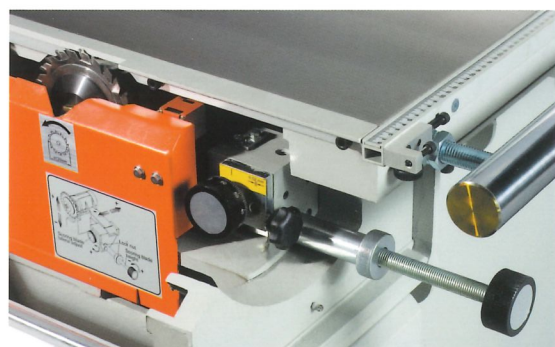

Scoring Saw Adjustment Unit

This is located at the right side of the machine. The movement of the sliding table can be adjusted from the front of the machine without the need of additional tools.



Miter Fence

It features reference positioning at $0^\circ \sim \pm 45^\circ$ scale for accurate degree reading as well as angular cutting.



Digital Display Rip Fence

The cutting width can be read directly on the digital display which features micro measurement for accurate positioning. (Optional)



Rapid Clamp and Clamping Shoe

(Optional)

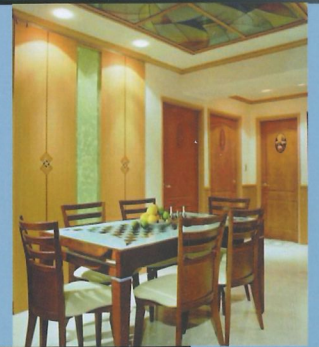

Specifications

Unit: mm

ITEM	MODEL	P-2500/2800/3200/3800 TA3X	P-2500/2800/3200/3800 TA	P-2500/2800/3200/3800 TM
Rectified cast iron fixed table dimensions		620 x 1,000	620 x 1,000	620 x 1,000
Sliding table dimensions		380 x 2,500 / 2,800 / 3,200 / 3,800	380 x 2,500 / 2,800 / 3,200 / 3,800	380 x 2,500 / 2,800 / 3,200 / 3,800
Main saw blade ϕ 305 (12")		●	●	●
Main saw blade ϕ 355 (14")		✓	✓	✓
Main saw bore		ϕ 30 mm (ϕ 25.4")	ϕ 30 mm (ϕ 25.4")	ϕ 30 mm (ϕ 25.4")
Max. cutting height with blade at 90°		100	100	100
Max. cutting height with blade at 45°		70	70	70
Main motor power 7.5 HP (5.5 kW)		●	●	●
Main motor power 10 HP (7.5 kW)		✓	✓	✓
Main blade speed		3,000 / 4,000 / 5,000 / 6,000 rpm	3,000 / 4,000 / 5,000 / 6,000 rpm	3,000 / 4,000 / 5,000 / 6,000 rpm
Scoring saw blade ϕ 120		●	●	●
Scoring saw blade bore		ϕ 22	ϕ 22	ϕ 22
Scoring motor power 1 HP (0.75 kW)		●	●	●
Scoring blade speed 8,000 rpm		●	●	●
Cutting width 1,000 mm		●	●	●
Cutting width 1,300 mm		✓	✓	✓
Cutting width 1,500 mm		✓	✓	✓
Cutting width adjustment		CNC controlled	Manual	Manual
Saw table extension 400 mm		●	●	●
Saw table extension 800 mm (CE)		✓	✓	✓
Mitre fence		●	●	●
Blade tilting adjustment		CNC controlled (0° ~ 45°)	Digital controlled (0° ~ 45°)	Manual (0° ~ 45°)
Main saw height adjustment		CNC controlled	Motorized	Manual
Scoring saw height adjustment		Motorized	Motorized	Manual
Scoring saw \pm direction adjustment		Motorized	Motorized	Manual
Blade tilting angle display		Digital display	Digital display	Simple / Digital display
Main blade speed display		Digital display	Digital display	Simple / Digital display
Overhead saw guard		Simple / Luxurious / CE	Simple / Luxurious / CE	Simple / Luxurious / CE
Blade tilting angle digital display		●	●	✓
Main blade speed digital display		●	●	✓
Crosscut fence digital display		✓	✓	✓
Rip fence digital display		-	✓	✓
Safety bar		✓	-	-
Hanging type control panel		✓	✓	-
Rapid clamp		✓	✓	✓
Tool frame		✓	✓	✓
Dust collection system		Main channel 5", Simple guard 2", Luxurious / CE guard 3"		

● = Standard ✓ = Optional

Technical Specifications

Sliding Table Cutting Lengths

Sliding table lengths	With or without scoring saw blade
2500 mm (98.43")	2400 mm (94.49")
2800 mm (110.24")	2700 mm (106.3")
3200 mm (128")	3100 mm (122.05")
3800 mm (149.61")	3700 mm (145.67")

Cutting Depths

Saw blade diameter	ϕ 255 (10")	ϕ 305 (12")	ϕ 355 (14")
Cutting depths at 90°	0~50 mm (0~2")	0~75 mm (0~2.95")	0~100 mm (0~4")
Cutting depths at 45°	0~35 mm (0~1.38")	0~53 mm (0~2.09")	0~70 mm (0~2.76")

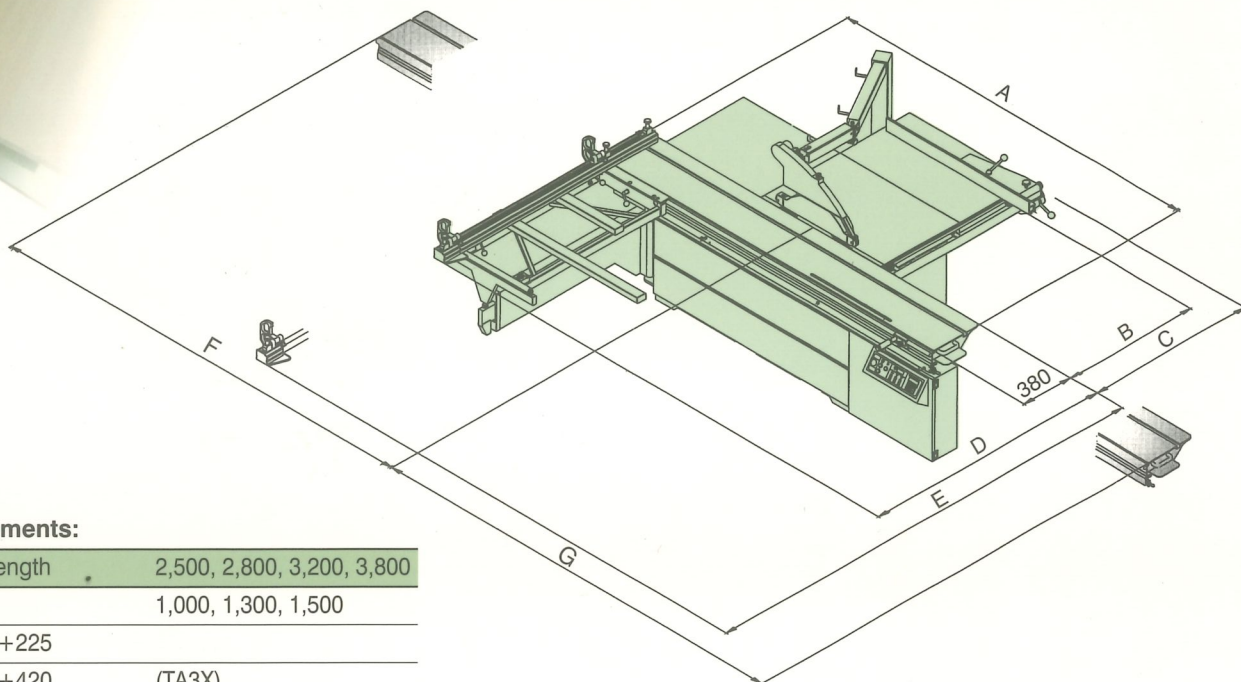

Space Requirements:

A: Sliding table length	2,500, 2,800, 3,200, 3,800
B: Cutting width	1,000, 1,300, 1,500
C: Cutting width +225	
Cutting width +420	(TA3X)
D: Crosscut fence	1,800
E: Crosscut fence	max. 3,215
F: Sliding table length +340	
G: Sliding table length +260	

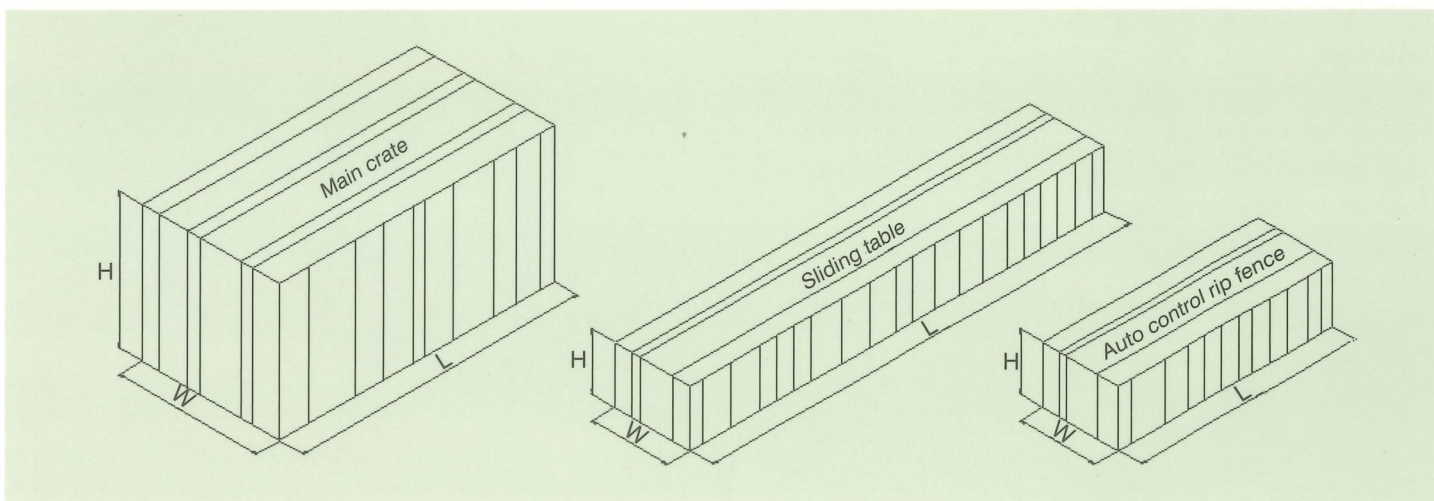

Crate Measurements:

	L x W x H
Main crate (Cutting width 1,000 & 1,300)	2,270 x 1,300 x 1,010 mm
Main crate (Cutting width 1,500 & TA3X)	2,270 x 1,300 x 1,070 mm
Sliding table length 2,500	2,600 x 470 x 360 mm
Sliding table length 2,800	2,900 x 470 x 360 mm
Sliding table length 3,200	3,290 x 470 x 360 mm
Sliding table length 3,800	3,900 x 470 x 390 mm
Auto. control rip fence 1,300	2,000 x 390 x 360 mm
Auto. control rip fence 1,500	2,210 x 390 x 360 mm

Machine Weights:

	N.W. / G.W.
Main crate TM (Cutting width 1,000)	800 / 980 kgs
Main crate TM (Cutting width 1,300)	820 / 1,000 kgs
Main crate TM (Cutting width 1,500)	840 / 1,020 kgs
Main crate TA (Cutting width 1,000)	858 / 1,030 kgs
Main crate TA (Cutting width 1,300)	878 / 1,050 kgs
Main crate TA (Cutting width 1,500)	898 / 1,070 kgs
Sliding table length 2,500	147 / 207 kgs
Sliding table length 2,800	167 / 227 kgs
Sliding table length 3,200	187 / 247 kgs
Sliding table length 3,800	207 / 267 kgs
Auto. control rip fence 1,300	56 / 75 kgs
Auto. control rip fence 1,500	59 / 78 kgs

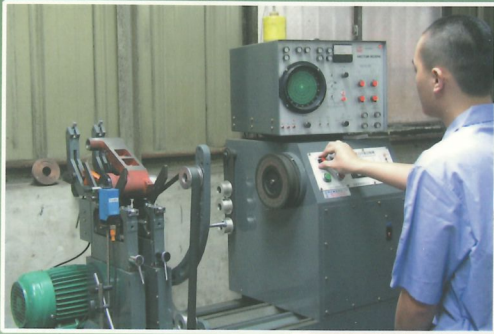

Balancing Adjustment



CNC Machining Equipment



AUTO. CAD Design Center



Automatic Robot Welging



Mass Production Line

All HOLYTEK sliding panel saws are designed with the latest software and precision machined using sophisticated equipment. With the utilization of only top quality parts and production, HOLYTEK's saws guarantee a lifetime of high performance and the best accuracy. For the best value in panel cutting - HOLYTEK.

HOLYTEK

HOLYTEK INDUSTRIAL CORP.

9F- I, NO. 400, SEC. I, CHANG PING RD., TAICHUNG, TAIWAN, R.O.C.

TEL: 886-4-2245-2818 (REP.) FAX: 886-4-2243-6928

E-mail: holytek@ms13.hinet.net

<http://www.holytek.com.tw>