

Idi Base 100

Bordatrice monolaterale elettronica

Idi Base 100 è la bordatrice IDM sempre pronta a lavorare con voi. Con tanta tecnologia in poco spazio e con una vasta serie di opzionali, Idi Base 100 è sempre all'altezza delle vostre aspettative. Adatta per l'applicazione di bordi sottili, ABS e massello fino a 12 mm, Idi Base 100 assicura bordature di elevata qualità.

NC single-sided edgebander

Idi Base 100 is the IDM ever ready-to-work edgebander. Great technology in a reduced space and a wide range of options. Idi Base 100 will satisfy your expectations. Suitable for thin, ABS and solid wood edges up to 12 mm processing, Idi Base 100 assures high quality edgebanding.

Plaqueuse de chants monolatérale électronique

Idi Base 100 est la plaqueuse IDM toujours prête à travailler pour vous. Elle possède beaucoup de technologies dans peu d'espace, et propose une grande quantité d'options. IDI BASE 100 sera toujours à la hauteur de vos attentes. Adaptée pour l'application de chants minces, d'ABS et de massif allant jusqu'à 12 mm, Idi Base 100 assure des placages de haute qualité.

Elektronische einseitige Kantenanleimmaschine

Idi Base 100 ist die immer gebrauchsfertige IDM Kantenanleimmaschine. Mit hoher Technologie und einer breiten Serie von Optionen in kleinem Raum ist Idi Base 100 immer ihren Erwartungen ebenbürtig. Die ist zur Anleimung dünner Kanten, ABS und Massiv bis 12mm geeignet und sichert Kantenanleimung hoher Qualität.

Chapeadora electrónica monolateral

Idi Base 100 es la chapeadora IDM siempre lista para trabajar con vosotros. Con mucha tecnología en pequeño espacio y una amplia serie de opciones, Idi Base 100 está siempre a la altura de vuestras expectativas. Apta para la aplicación de cantos delgados, ABS y macizo hasta 12 mm, Idi Base 100 asegura chapeados de alta calidad.



COMIT

SINCERT



REG. N. 091/E
UNI EN ISO 9001:2000

Idi Base 100

WWW.IDM.COM

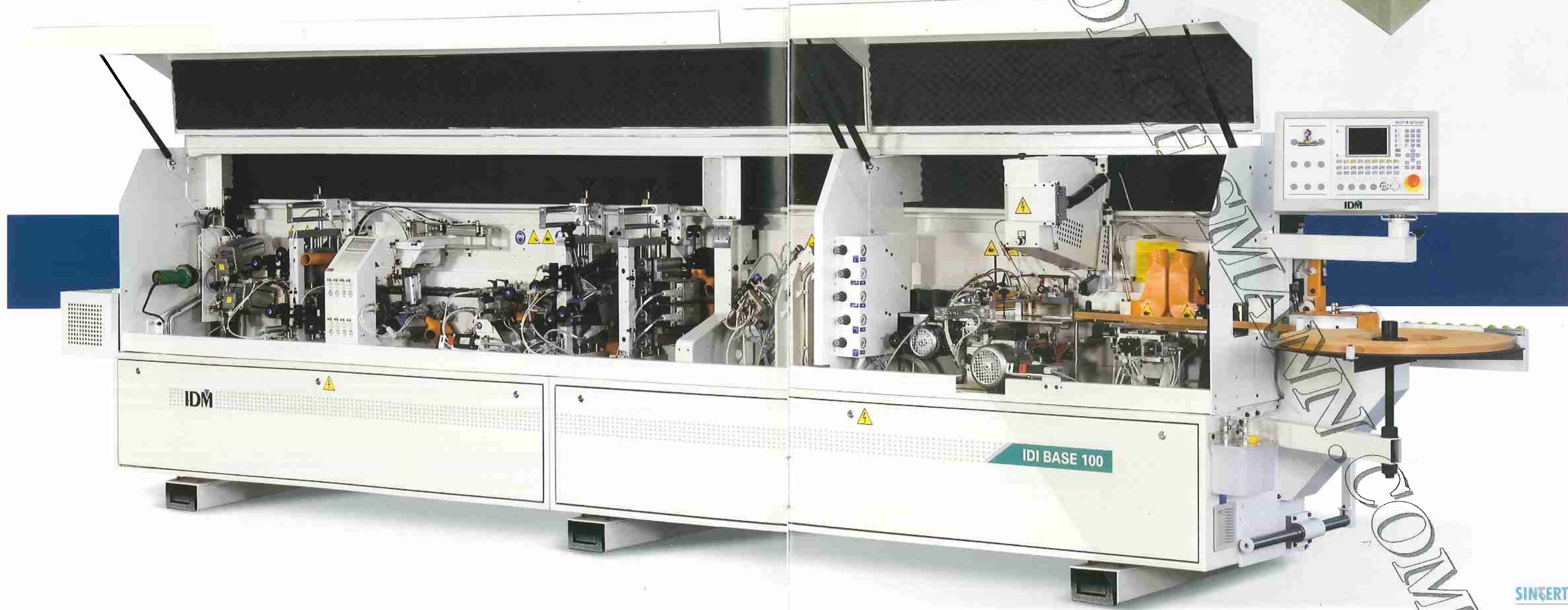
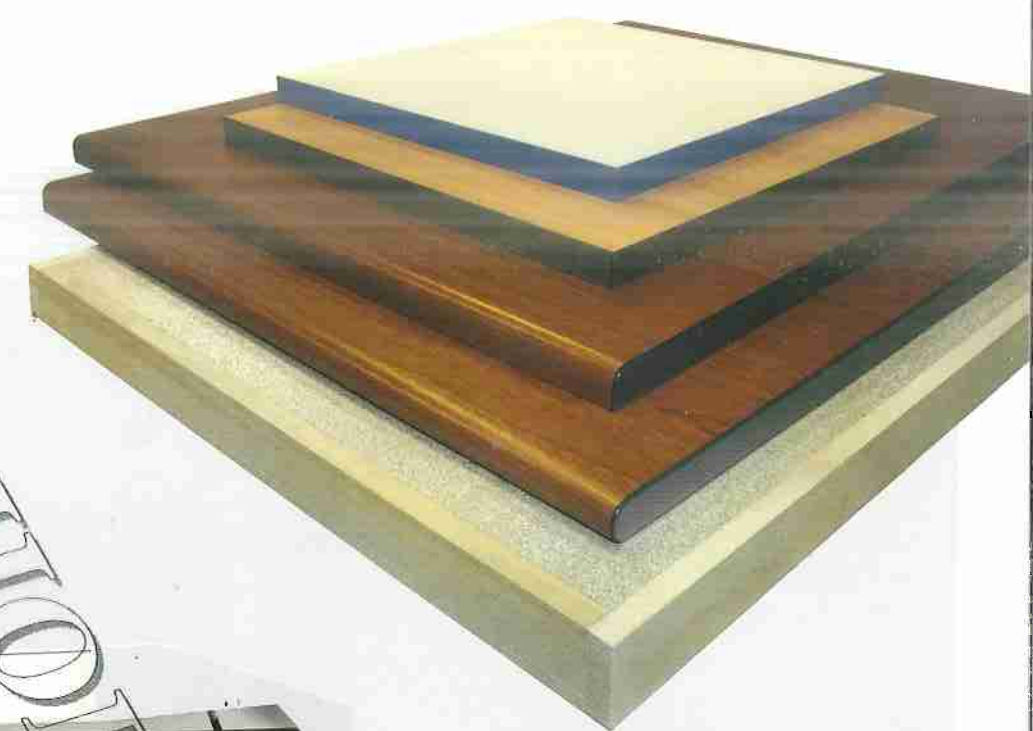

WWW.IDM.COM

SINGERT



IDM

REG. N. 0918
UNI EN ISO 9001:2000

Gruppi operatori

Working units

Groupes de travail

Arbeitsaggregaten

Grupos operadores

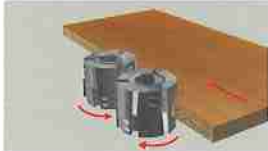
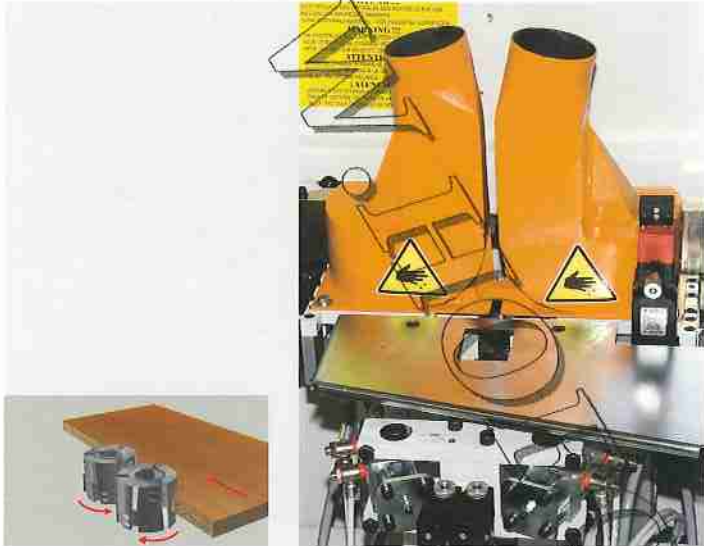

Gruppo rettificatore
Pre-milling unit
Groupe rectifieur
Fügefräsaggregat
Grupo rectificador



Gruppo incollaggio
Gluing unit
Groupe encolleur
Anleimaggregat
Grupo encolado

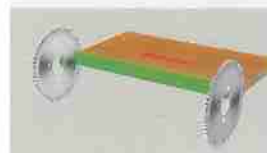
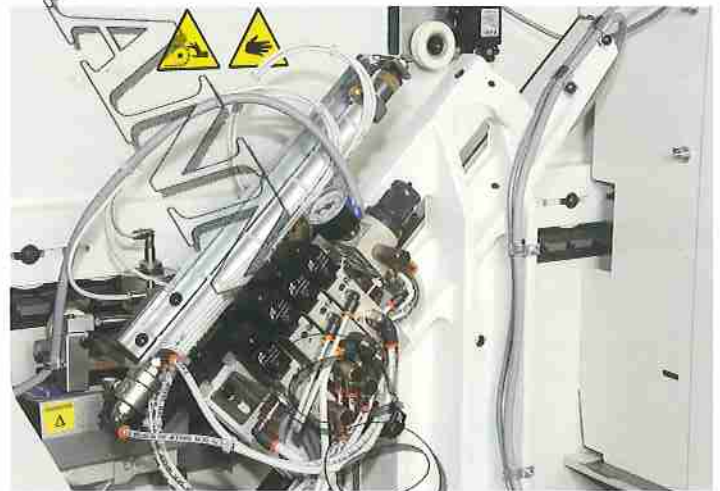

Gruppo traseatore
End-trimming unit
Groupe de coupe en bout
Kappaggregat
Grupo retesteador

edsystem

Il sistema di aspirazione ottimizzato ED-SYSTEM migliora la qualità e il rendimento dell'aspirazione utilizzando utensili e cappe di aspirazione specificatamente studiati per questo scopo.

The optimized ED-SYSTEM improves the chip suction's quality and performance by means of tools and suction hoods precisely designed for this purpose.

Le système d'aspiration optimisé EDSYSTEM améliore grandement la qualité et le rendement du dépeussierage. Il utilise des outils et des capots de captations spécialement étudiés pour arriver à ce résultat.

Der optimierte Absaugungssystem EDSYSTEM verbessert die Qualität und die Leistung der Absaugung in dem er Werkzeugen und Absaughauben benutzt, die gerade zu diesem Zweck gezeichnet wurden.

El sistema de aspiración optimizado EDSYSTEM mejora la calidad y el rendimiento de l'aspiración utilizando herramientas y campanas de aspiración Estudiados específicamente para este objeto.

Idi Base 100

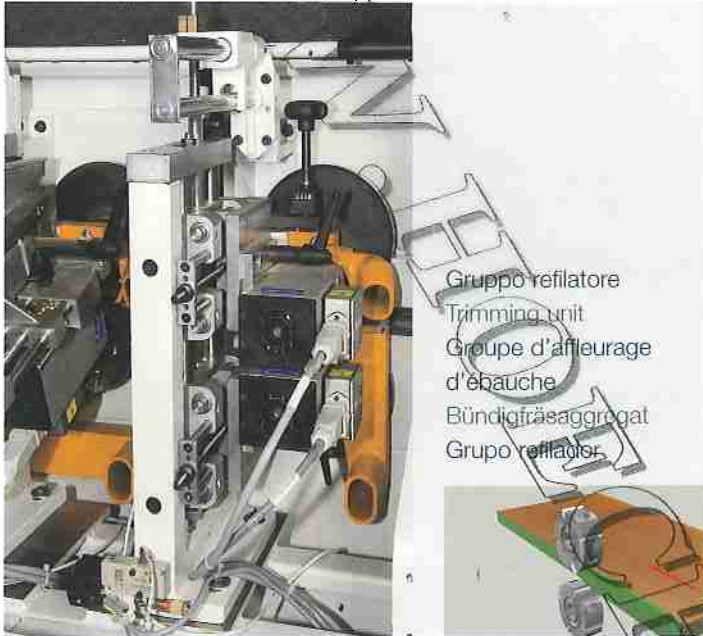

Gruppo rifilatore
Trimming unit
Groupe d'affleurage
d'ébauche
Bündigfräsaggregat
Grupo refilador

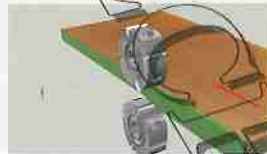

Gruppo rifilatore-
spigolatore
Fine trimming unit
Groupe d'affleurage
de finition
Bündigfräs-/ Fein
Radiusfräsaggregat
Grupo refilador-
biselador

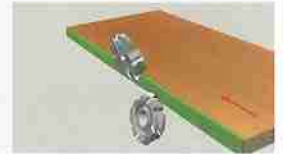

Gruppo arrotondatore-refilatore
Corner rounding trimming unit
Groupe d'arrondissement - affleurage
Abrundungs-Bündigfräsaggregat
Grupo redondeador - refilador

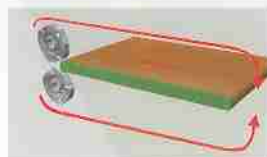

Gruppo raschiabordo
Edgescraping unit
Groupe racleur
de chant
Ziehklingenaggregat
Grupo rascador
de canto



COMET

Composizioni Compositions Compositions Ausstattung Composiciones

Applicazione bordo sottile e massello Processing of thin and solid wood edges Application du chant mince et bois massif Anleimung der dünnen Kante und Massivholz Aplicación de canto delgado y macizo

IDI BASE 100 - A

2-S

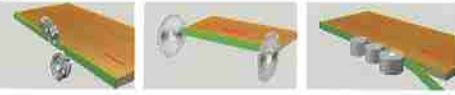

IDI BASE 100 - V

2-S

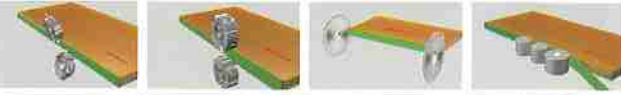

IDI BASE 100 - RT

2-S

1-T

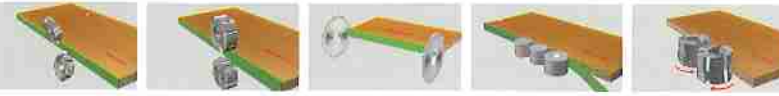

1-AA

Applicazione bordo sottile, massello e ABS su 2 lati Processing of thin, solid wood and ABS edges on 2 sides Application du chant mince, bois massif et ABS sur 2 côtés Anleimung der dünnen Kanten, Massivholz und ABS auf 2 Seiten Aplicación de canto delgado, macizo y ABS sobre 2 lados

IDI BASE 100 - VP

3-S

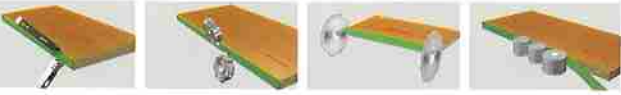

IDI BASE 100 - RS

3-S

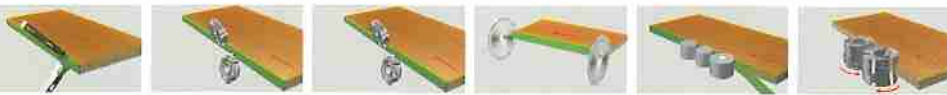

1-AA

Applicazione bordo sottile, massello e ABS su 4 lati Processing of thin, solid wood and ABS edges on 4 sides Application du chant mince, bois massif et ABS sur 4 côtés Anleimung der dünnen Kanten, Massivholz und ABS auf 4 Seiten Aplicación de canto delgado, macizo y ABS sobre 4 lados

IDI BASE 100 - 2

3-S

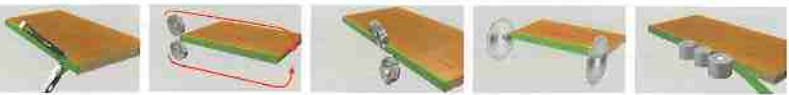

IDI BASE 100 - T2

3-S

1-T

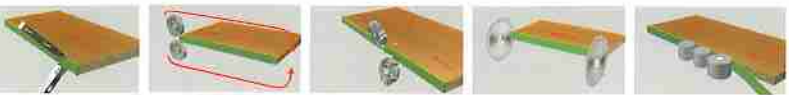

IDI BASE 100 - R2

3-S



1-AA

IDI BASE 100 - RS2

3-S



1-AA

IDI BASE 100 - RT2

3-S

1-T



1-AA

Spazi liberi

Free spaces

Espaces libres

Freie Räume

Espacios libres

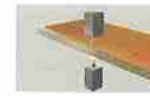

1-AA

Spazio libero per gruppo antiadesivizzante
Free space for anti-adhesive unit
Espace libre pour groupe antiadhésif
Freier Raum für Antihafmittelaufgabegerät
Espacio libre para grupo antiadhesivo



1-T

Spazio libero per gruppo toupie
Free space for grooving unit
Espace libre pour groupe toupie
Freier Raum für Fräsaggregat für Nuten
Espacio libre para grupo tupí para ranuras

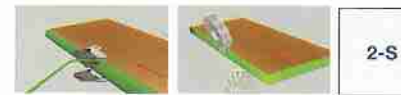

2-S

Spazio libero per 2 gruppi finitori (raschiacolla, spazzole)
Free space for 2 finishing units (gluescraping unit, buffing unit)
Espace libre pour 2 groupes de finition (racleur de colle, brosses)
Freier Raum für 2 Nachbearbeitungsaggregate (Flächeziehklingen- und Bürstenaggregat)
Espacio libre para 2 grupos de acabado (rascacola, cepillos)

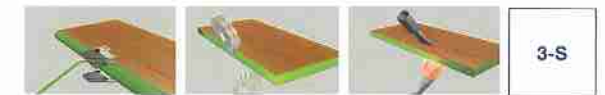

3-S

Spazio libero per 3 gruppi finitori (raschiacolla, spazzole, ravnivatore bordo)
Free space for 3 finishing units (gluescraping unit, buffing unit, edge brightening unit)
Espace libre pour 3 groupes de finition (racleur de colle, brosses, raviveur de chant)
Freier Raum für 3 Nachbearbeitungsaggregate (Flächeziehklingenaggregat, Bürstenaggregat, Aggregat zur Aufrischung der Kante)
Espacio libre para 3 grupos de acabado (rascacola, cepillos, avivador de canto)

Principali opzionali

Main options

Options principales

Hauptsächliche Optionen

Opciones principales

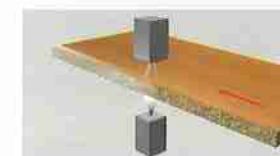

Gruppo antiadesivizzante
Anti-adhesive unit
Groupe antiadhésif
Antihafmittelaufgabegerät
Grupo antiadhesivo

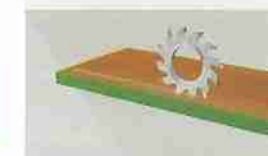

Gruppo toupie
Grooving unit
Groupe toupie pour fraisages
Fräsaggregat für Nuten
Grupo tupí para ranuras



Gruppo raschiacolla
Gluescraping unit
Groupe racleur de colle
Flächeziehklingenaggregat
Grupo rascacola

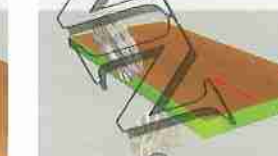

Gruppo spazzole
Buffing unit
Groupe brosses
Bürstenaggregat
Grupo cepillos

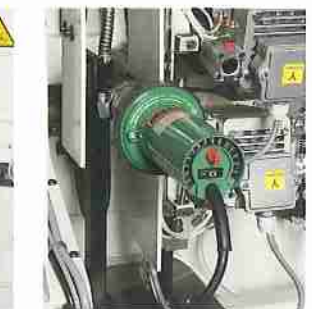

Gruppo ravnivatore bordo
Edge brightening unit
Groupe raviveur de chant
Aggregat zur Aufrischung der Kante
Grupo avivador canto



Gruppo prefusione
Pre-melting unit
Groupe de préfusion
Vorschmelzenaggregat
Grupo prefundidor

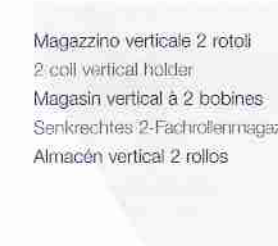

Magazzino verticale 2 rotoli
2 coil vertical holder
Magasin vertical à 2 bobines
Senkrechtliches 2-Fachrollenmagazin
Almacén vertical 2 rollos

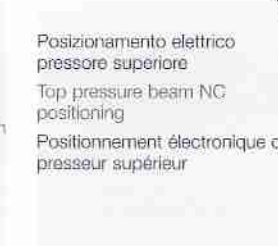

Posizionamento elettrico pressore superiore
Top pressure beam NC positioning
Positionnement électronique du presseur supérieur



Elektronisches Positionieraggregat
Positionierung
Posicionamiento electrónico presor superior

Controllo
numerico

Numerical
control

Contrôle
numérique

Numerische
Steuerung

Control
numérico



Comando dei gruppi operatori e avviamento automatico dei motori - Memorizzazione fino a 100 programmi di lavorazione - Selezione del primo o secondo passaggio senza cambio programma - Gestione della diagnostica - Report di produzione.

Working units control and automatic start of motors - Up to 100 memorize processing programs - Selection of the first or second pass without changing the program - Trouble shooting - Production reports.

Contrôle des groupes de travail et démarrage automatique des moteurs - Capacité de mémorisation allant jusqu'à 100 programmes d'usinage - Sélection du premier ou second passage sans changement de programme - Gestion du diagnostique - Rapports de production.

Steuerung der Aggregate und automatisches Starten der Motoren - Speichern bis zu 100 Bearbeitungsprogramme - Wahl des ersten und zweiten Arbeitsgangs ohne Programmwechsel - Leitung der Diagnose - Bearbeitungsberichten.

Mando de los grupos operadores y arranque automático de los motores - Capacidad de memorización hasta 100 programas de trabajo - Selección de la primera y segunda pasadas sin cambio de programa - Gestión de los diagnósticos de errores - Report de producción.

Servizio
assistenza

After sales
service

Service
assistance

Kundendienst

Servicio
asistencia



IDM garantisce ai propri clienti un servizio di assistenza che assicura:

- affiancamento in fase di avvio e messa a punto delle macchine;
- corsi di specializzazione per gli operatori presso la sede o, su richiesta, in qualsiasi parte del mondo;
- unità periferiche dotate di magazzini ricambi e personale tecnico anche in aree geografiche decentralizzate per un pronto intervento tecnico per qualunque necessità.

IDM after sales service guarantees:

- support in the start-up phase and fine tuning of the machine;
- specialisation training courses for the operators at our offices, or upon request, in any part of the world;
- subsidiary facilities with spare parts inventory and technical personnel, even in decentralised geographical areas, for rapid technical intervention whenever necessary.

IDM garantit à ses clients un service d'assistance qui assure:

- une collaboration en phase de mise en marche et mise au point des machines;
- des cours de spécialisation pour les opérateurs sur place ou, sur demande, partout dans le monde;
- des unités périphériques dotées de magasins de pièces de rechange et de personnel technique, même en des points géographiques décentrés, destinés à fournir une intervention technique rapide dans tous les cas de figure.

IDM garantiert einen Kundendienst mit folgenden Leistungen:

- Hilfestellung bei Inbetriebnahme und Einrichten der Maschine;
- Schulungen für die Bediener bei IDM oder auf Wunsch überall auf der Welt;
- örtliche Servicestellen mit Ersatzteillagern und technischem Personal auch in abgelegenen Gebieten für rasche technische Reparaturen.

IDM garantiza a sus clientes un servicio de asistencia que asegura:

- asistencia en fase de arranque y puesta a punto de las máquinas;
- cursos de especialización para los operadores en la sede o, a petición, en cualquier parte del mundo;
- unidades periféricas dotadas de almacenes de repuestos y personal técnico también en zonas geográficas alejadas para una asistencia técnica inmediata en caso de cualquier necesidad.

Idi Base 100

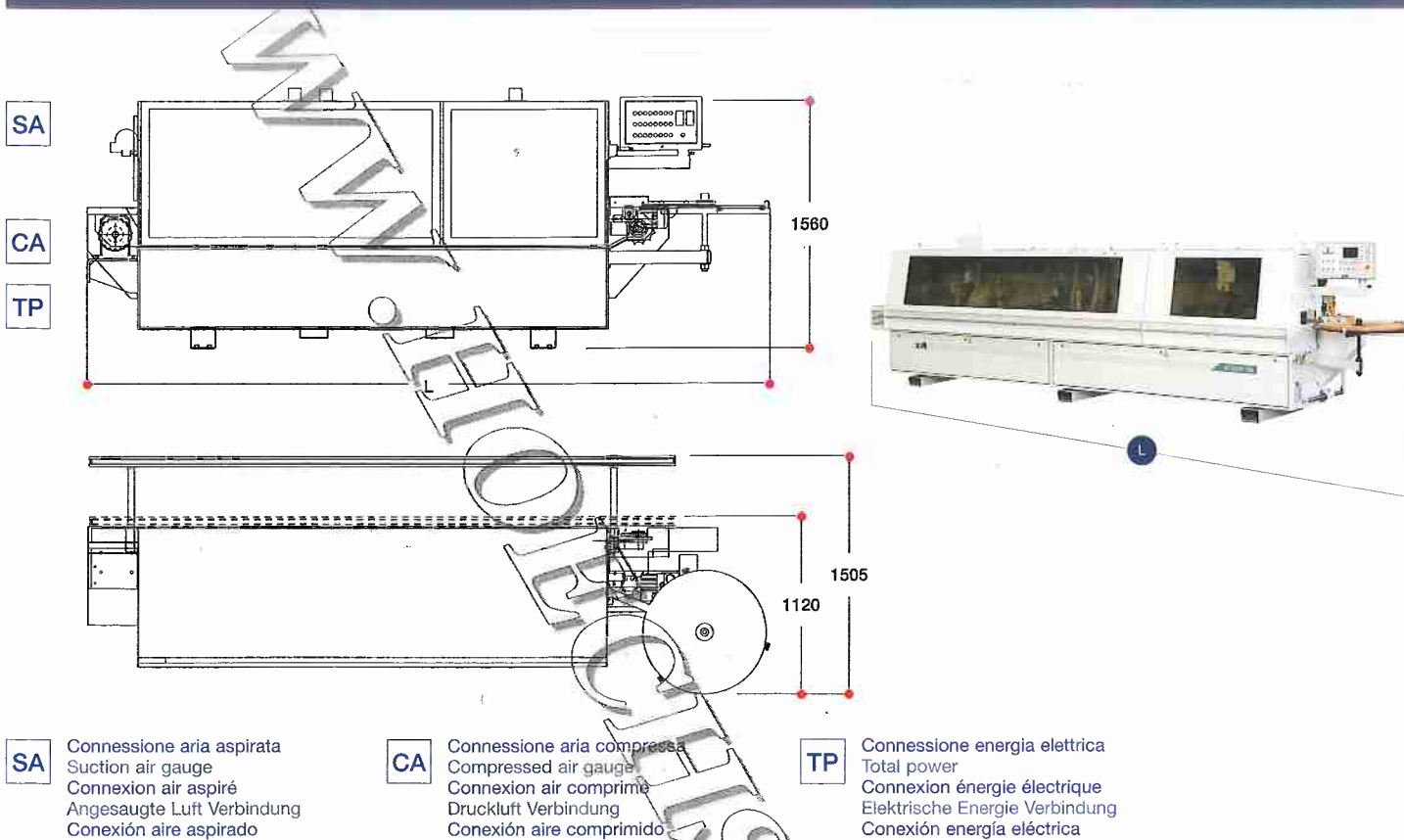

SA Connessione aria aspirata
Suction air gauge
Connexion air aspiré
Angesaugte Luft Verbindung
Conexión aire aspirado

CA Connessione aria compressa
Compressed air gauge
Connexion air comprimé
Druckluft Verbindung
Conexión aire comprimido

TP Connessione energia elettrica
Total power
Connexion énergie électrique
Elektrische Energie Verbindung
Conexión energia eléctrica

IDI BASE 100	IDI BASE 100 A (33)	IDI BASE 100 V (35)	IDI BASE 100 RT (45)	IDI BASE 100 VP (41)	IDI BASE 100 RS (47)	IDI BASE 100 2 (47)	IDI BASE 100 T2 (53)	IDI BASE 100 R2 (53)	IDI BASE 100 RS2 (55)	IDI BASE 100 RT2 (55)
Lunghezza totale (L) mm Total length (L) mm Longueur totale (L) mm Gesamtlänge (L) mm Longitud total (L) mm	4310	4510	5510	5110	5710	5710	6310	6310	6510	6510
Peso netto Kg Weight Kg Poids Kg Gewicht kg Peso kg	1530	1620	1900	1780	1990	1990	2230	2230	2320	2320

Dati tecnici	Technical specifications	Caractéristiques techniques	Technische Eigenschaften	Características técnicas
Spessore max del bordo in rotolo	Max coil material thickness	Épaisseur maxi du chant en bobine	Max. Kantenstärke für Rollenkanten	Espesor máx del canto en rollos mm 3 x 45
Spessore max del bordo in striscia	Max strip material thickness	Épaisseur maxi du chant en bande	Max. Stärke Streifenkanten	Espesor máx del canto en tiras mm 0,4 - 8 (12 optional)
Spessore min/max pannello - con gruppo arrotondatore-refilatore	Min/max panel thickness - with corner rounding trimming unit	Épaisseur mini/maxi du panneau - avec groupe d'arrondissement-affleurage	Min. und max. Plattenstärke - mit Fasefräser- und abrundungs-aggregat	Espesor min/máx del panel - con grupo redondeador-refilatore mm 8 - 55
Velocità di avanzamento	Feed speed	Vitesse d'avance	Vorschubgeschwindigkeit	Velocidad de avance m/min 10 - 45 (12/18 optional)

I dati tecnici possono variare in funzione della composizione scelta. Per esigenze dimostrative alcune foto riproducono macchine complete di accessori. Senza nessun preavviso i dati tecnici possono essere modificati. Le modifiche non influenzano la sicurezza prevista dalle norme CE.

Technical specifications may vary according to the composition chosen. For demonstration purposes, several photographs show machines complete with accessories. The technical data can be modified without advance notice, the modifications do not influence the safety prescribed by the CE regulations.

Les caractéristiques techniques peuvent varier en fonction de la composition. Dans ce catalogue les machines sont représentées avec des options. La société se réserve le droit de modifier les données techniques et les dimensions sans préavis mais ces modifications n'ont pas d'incidence sur la sécurité prévue par la norme CE.

Die technischen Daten können auf die gewählten Compositionen an. Zur Veranschaulichung sind die Maschinen auf einigen Fotos komplett mit Zubehörfteilen abgebildet. Änderungen der technischen Daten ohne Vorankündigung vorbehalten. Eventuelle Änderungen haben keinerlei Auswirkung auf die Sicherheit gemäß EG-Normen.

Los datos técnicos pueden variar en función de la composición elegida. En este catalogo las máquinas han sido representadas con algunos accesorios. La empresa se reserva el derecho de modificar los datos y las medidas sin previo aviso sin influir en la seguridad prevista de la certificación CE.