

## Finger jointing line

## DEMO 1

Capacity: 6 m/min

Board length: Min. 3000 mm up to Max. 6100 mm

JOINT  
TYPE

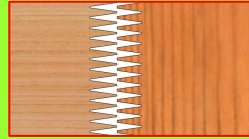

V Vertical

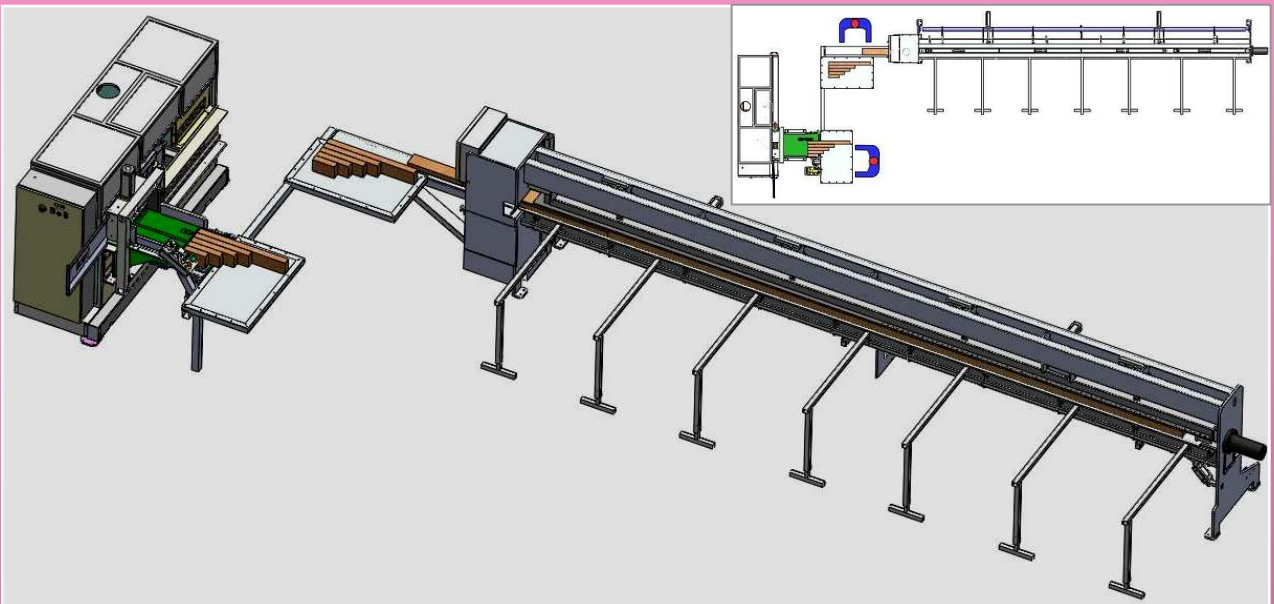

### THE LINE CONSISTS OF THE FOLLOWING UNITS

- Shaper unit
- Press unit - one filling canal - length 6100 mm

### DESCRIPTION OF WORKING

The operator places the package of elements on the band conveyor. After pressing key cycle the package is automatically arranged. In the first ride the package is done on one side, then it returns to the initial position where the operator manually turns it upside down. Then he presses the key cycle again, the package is being arranged again, then done on the other side and glue is applied automatically. When the working is done, the package automatically goes to the depositing table in front of the press. Here, the operator correctly puts together piece by piece creating a board which he manually pushes into the press. When the press is full an automatic cycle takes place – pressing, cutting in length and deviation on the forks at the exit of the press.