

Finger jointing line

DEMO 3

Capacity: 9 m/min

Board length: : Min. 1000 mm up to Max. 6100 mm

JOINT
TYPE

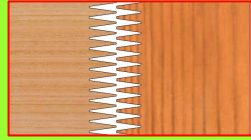

V Vertical

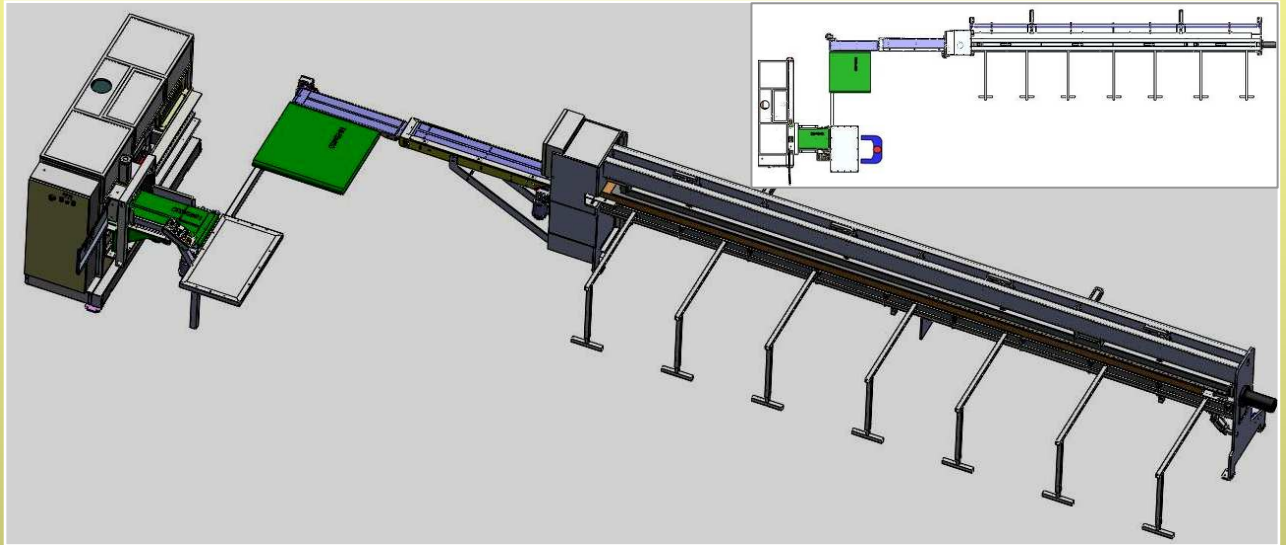

THE LINE CONSISTS OF THE FOLLOWING UNITS

- Shaper unit
- Dumper
- Press unit - one filling canal - length 6100 mm

DESCRIPTION OF WORKING

The operator places the package of elements on the band conveyor. After pressing key cycle the package is automatically arranged. In the first ride the package is done on one side, then it returns to the initial position where the operator manually turns it upside down. Then he presses the key cycle again, the package is being arranged again, then done on the other side and glue is applied automatically. When the working is done, the package automatically goes to the depositing table in front of the dumper. Dumper unit pushes the package to output band conveyor. Here the elements are dumped on the belt. Elements go one by one to band conveyor where they are loosely and correctly assembled. The board is then pushed under the rolls filling the press. When the press is full an automatic cycle takes place – pressing, cutting in length and deviation on the forks at the exit of the press.