

Sawing can be this easy.

TC660

MARTIN



TC660

The sliding table saw for beginners.

As versatile as the types of wood you want to work with.

It is generally true that sliding table saws are the most important tool in the joiner's workshop. The fact is that your new sliding table saw must be able to reliably cut precisely sized cuts and rough pre-cuts. It should be easy to operate without error or fatigue and should continue to work reliably for years. So don't make any compromises when it comes to choosing your sliding table saw – and opt for a Martin from the outset, such as the TC660, for example.



TC660 with accessories

TC66x128 | Infinitely locking design of sliding table

TC66x285 | On switch on sliding table

TC66x415 | Scoring-saw blade set for scoring-saw unit

TC66x450 | Motor power 5.5 kW including automatic star-delta starting

Clear and easy operation | Standard

The controls are located directly in the working position. Cutting height and tilt are quickly and easily adjusted. The cutting angle is easily adjusted on the TC660 using the hand wheel. The cutting height is altered using an electric motor. The height and lateral position of the standard scorer can be easily and safely adjusted while the machine is running.

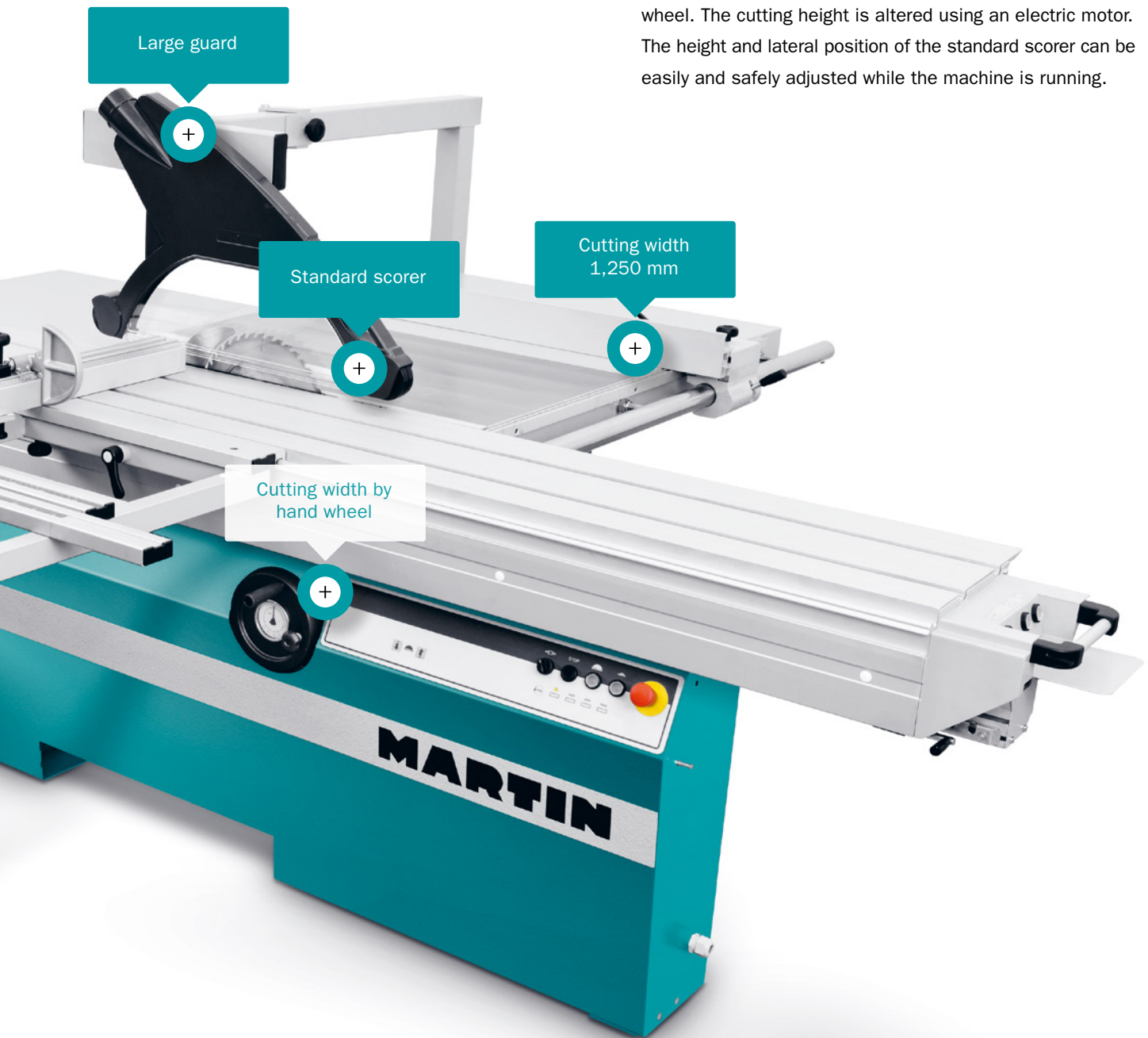

Powerful drive – scorer included.

The heavy cast saw unit is securely guided in generously dimensioned tilting segments, the cutting height adjustment runs on linear guides. The saw blade is driven by a 4 kW motor. Motors with 5.5 kW and 7.5 kW are also optionally available. The basic models of all machines have a powerful 2-axes scoring system with its own drive, adjustable from 2.8 to 3.6 mm, for perfect cutting of coated boards.

Convenient belt change | Standard

Change the speed of the TC66x machines comfortably from above through the table plate. This contribution to ease of operation and work results should not be underestimated.

A variety of options for efficient sawing.



Rip fence fine adjustment | Standard

Rip fence | Standard

The cutting width of both machines is easily adjusted by a scale. Fine adjustment goes without saying. Using the cross-cut fence it is possible to cut angles of 90° to 44°. Length compensation is integrated.



Length compensation in angle cuts | Standard

Length compensation | Standard

The TC66x series features simple length compensation for angle cuts. This allows you to always cut the correct length even when making angle cuts.



Sliding table on switch | TC66x285

ON - OFF on sliding table | TC66x285

This option is useful for anyone who repeatedly deals with large board formats. The machine can also be switched on and off if large formats prevent access to the control panel.



Parallel cutting support | TC66x200

Support for parallel cuts | TC66x200

The optional support helps you when handling large boards and can be very useful when making parallel cuts.

TC660

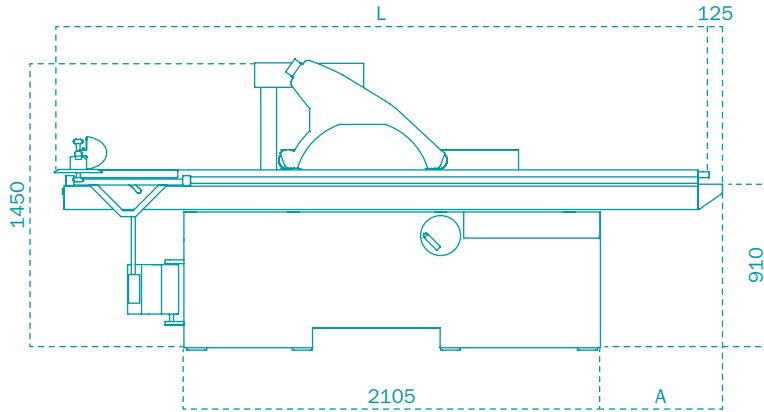

TC660 | Side view

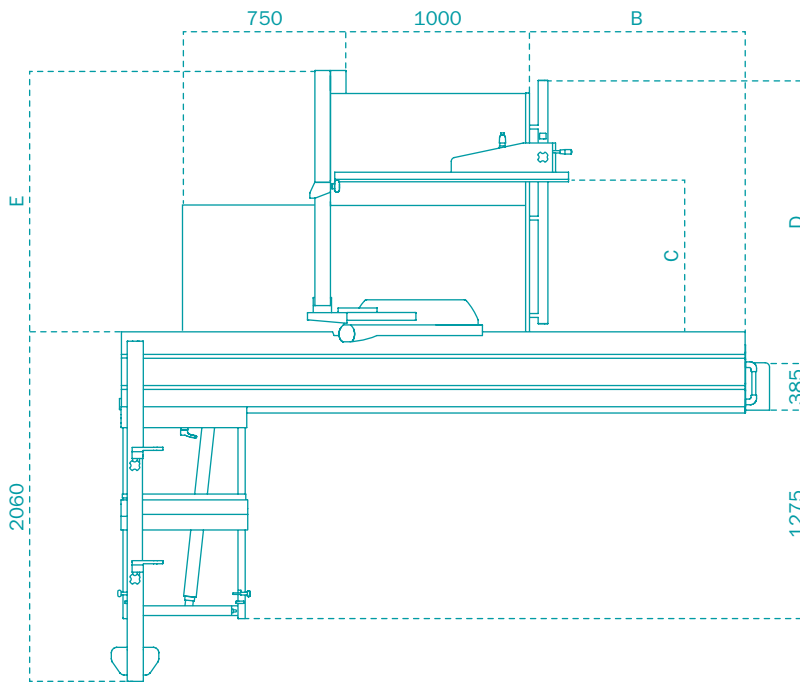

TC660 | Plan view

Sliding-table length

L	A	B
2150	158	600
2600	317	825
3200	617	1125
3800	917	1425

Cutting width

C	E
1250	1590
1600	1890

Technical data

TC660

Motor power optional	4.0 kW 5.5 kW 7.5 kW
Cutting height	130 mm
Saw-blade tilting range	-1° – +46°
Saw blade diameter	400 mm
Speed	3,000 4,000 5,000 rpm
Main saw blade change	classic
Blade thickness	max. 6 mm special tools up to 20.0 mm (0°)
Cutting width optional	1,250 mm 1,600 mm
Sliding table length optional	3.2 m 2.15 2.6 3.8 m
Control	–
Display resolution	0,1 mm 0,1°
Control panel	in frame
Cutting angle/height	Height: electrically by push button (rapid feed and creep) Angle: Hand wheel with tilting angle display
Cutting width	by hand, fine adjustment according to scale
Extraction connection	120 mm on frame 80 mm on guard
Weight	approx. 745 – 850 kg

The machines generate very little dust as per BGI 739-1 Annex 1.

All dimensions in millimetres. Made in the European Community.

Dimensions and specifications subject to technical innovation and may be changed without notice.

Illustrations may differ from the original. The binding technical features and equipment are given in the applicable price list.

Visit us at:

Website



Facebook



YouTube



Brochure



Contact us at:
+49 (0) 8332 911 - 0
sales@martin.info

MARTIN