

DRILLING AND INSERTION MACHINE FOR HINGES

macchine e sistemi **OMAL**

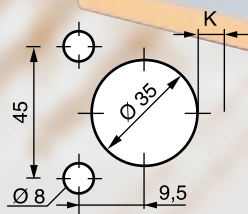

The OMAL drilling and insertion machine is designed to drill and PNEUMATICALLY insert SALICE hinges thus eliminating operator fatigue.

TASK: Reliable drilling and complete insertion of the hardware

SAFETY: A special electronic device activates the motor ONLY during drilling operations, the motor stops during the insertion phase.

The machine is designed to conform with the latest safety guidelines.

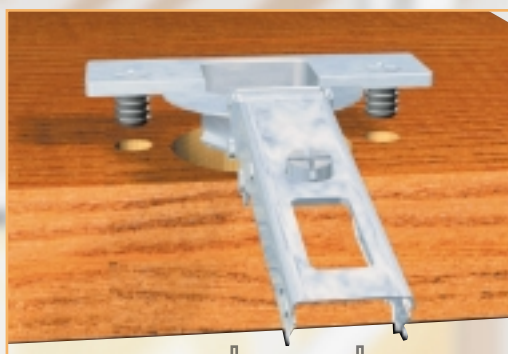

Insert easy



STANDARD EQUIPMENT:

- 1,5 HP motor
- 3 spindles gearbox (boring pattern 45x9,5)
- Center fence
- Table (700 mm. x 400 mm.)
- 2 tilt stops (to index panels on the fence)
- Insertion RAM
- Set of drill bits - 1 x 35 mm. RH bit + 2x8 mm. LH bits
- Tool kit
- Operators manual

TECHNICAL DATA:

- Interchangeable 3 spindle gearbox
- Motor 1,1 KW-1,5 hp - 60 Hz
- Voltage 110/1 ph
- Shank diameter Ø 10 mm.
- Required air pressure 6 bar/85 Psi
- Table size 700 mm. x 400 mm.
- Weight 40 Kg /88 Lbs

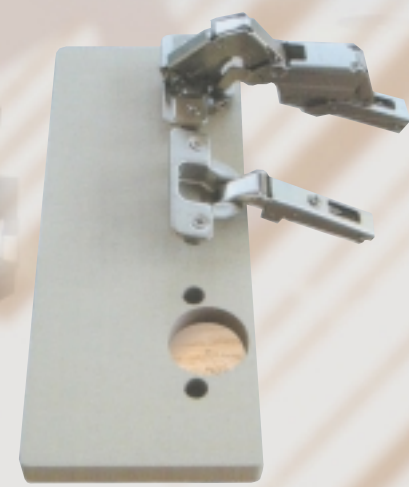

HINGE DRILLING

DEALER NAME

OMAL S.r.l.
Via Adda 1
22070 Senna Comasco-Italy
Tel +39-031-561308
Fax +39-031-561277
E-mail info@omalsystem.it
Web www.omalsystem.it