

CNC Cross-Cut Systems

Series 11

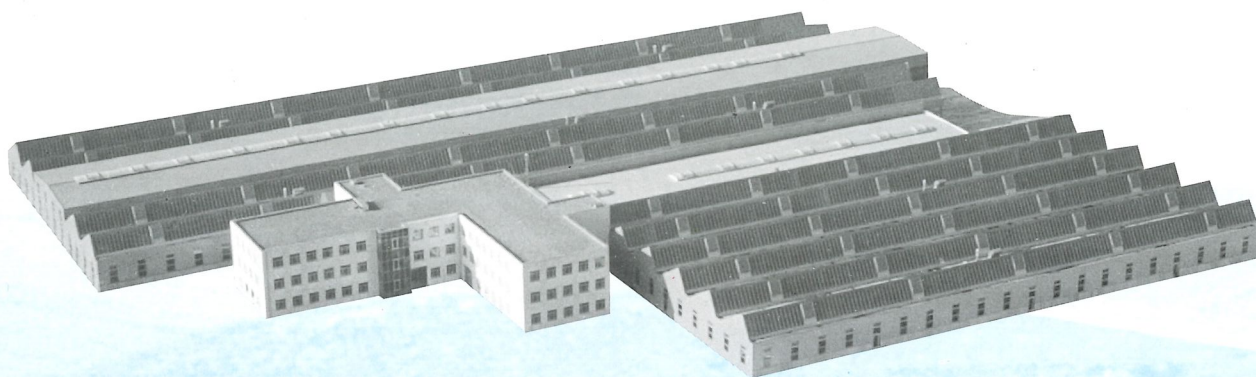



Maschinenfabrik GmbH & Co.

CNC

Cross-Cut Systems

Series

11



Comprehensive

Reliable

Flexible

Professional

High acceleration

Excellent

Ease of maintenance

Convenient

Newly developed

Comprehensive

Reliable

Flexible

Professional

High acceleration

Excellent

Ease of maintenance

Convenient

Newly developed

Series 11

In 1975 PAUL was the first German manufacturer to build a computer-controlled cross-cut saw with yield optimization. Our today's machines reflect over 25 years of experience. Thanks to their continuous development and upgrading, the PAUL 11 series are up to the latest state of technology, even many years after their market launch. We design and manufacture all machines and handling equipment and program the associated CNC controls in-house. For special applications our standard machines are individually adapted and extended by the specific control functions required.

Model 11,

the smaller sister of the Series 14 Cross-Cut Systems

Many of the features distinguishing the larger Series 14 are also incorporated in the model 11 machines

- A thoroughly engineered machine frame guarantees stability and durability.
- Advanced engineering design combined with easy-to-use, user-friendly diagnostic software to ensure trouble-free operation
- High-capacity maintenance-free feed drive system for fast acceleration
- Large diameter bottom feed rollers for a reliable and smooth transport even of difficult timber
- Independently pressure-loaded, large diameter top feed rollers to handle thickness variations in the timber
- Overdimensioned bearings for long service life
- Sound enclosed design for noise reduction and improved working conditions
- Industrial modular electronic components developed in-house
- High-grade components from renowned suppliers

Additional features on the model 11:

- Outstanding price-performance ratio
- Newly developed timber infeed by a durable self-centering timing belt
- Increased feed speed providing high output
- Optimum cutting range suiting most applications



Fig. 1: Model 11KE

Durability, high acceleration and reliability are essential features for high-volume production.

Also on Model 11

Yield Optimization

- Partial optimization
- Full optimization for 8 timber grades and 8 finger-joint grades
- Optimization with priorities
- Quality optimization for minimum waste or with priorities

Options

- Connection of several cross-cut saws by computer network MAX-I-Net
- Remote diagnostics via modem / ISDN



The control center of the CNC cross-cut system is the MAXI 4.0 CNC control

- PC with Pentium processor
- High resolution VGA color monitor
- Comprehensive operator support by context-sensitive screens
- Easy-to-understand error messages
- Auto-priority function
- 16 statistics with matrix allocation program to timber grades and widths
- Graphic display buffer showing previously processed boards on the monitor
- Self-check covering all machine functions



Fig. 2: MAXI 4.0 CNC control

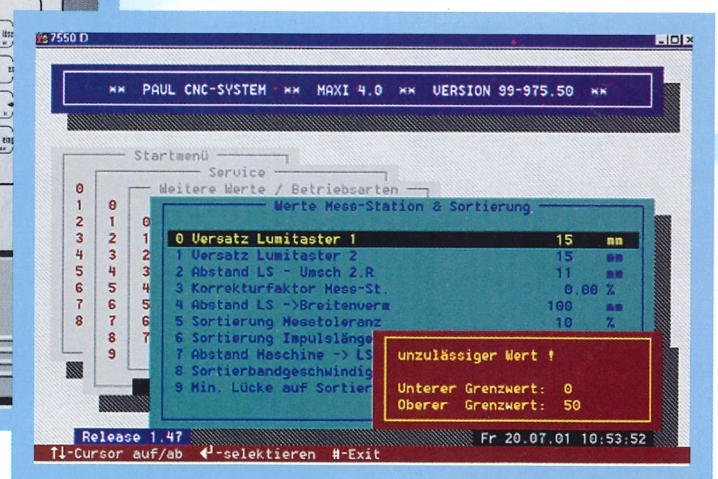

Fig. 3: MAXI 4.0 color monitor

For more detailed information on the MAXI 4.0 control, please review our brochure B120.16/4

The PAUL series 11 is a combination of high technology and proven practical features.

Model 11 MKL

for automatic length cutting with full optimization

The top model...

... of the 11 series feeds the marked timber through the measuring station where its full length (optionally also its

width and thickness) is measured and scanned for crayon marks. The board will be optimized according to the data obtained and the cutting list by

the MAXI 4.0 control. The luminescent scanner in the measuring station recognizes the crayon marks on the timber. As an option two luminescent scanners are available for quality changeover and defect marking.



Fig. 4: Safety enclosed ejector

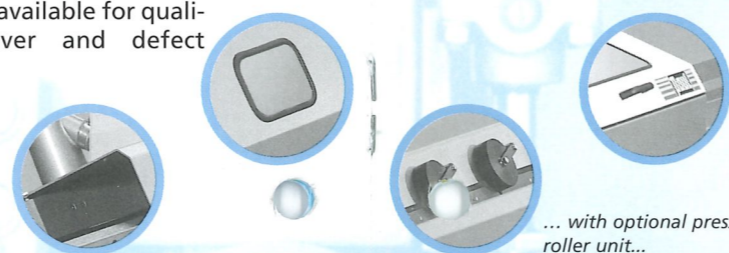

... with optional pressure roller unit...

Optimization

A full optimization of the timber including defect cutting is only possible on model 11MKL.

Only if the control knows all the board data the fixed lengths in the cutting list can be combined in such a way that either ...

- waste is reduced to a minimum or ...
- certain lengths are cut with priority or ...
- the timber is optimized according to different qualities or ...
- according to prices or ...
- finger-joint pieces can be cut in up to 8 different grades

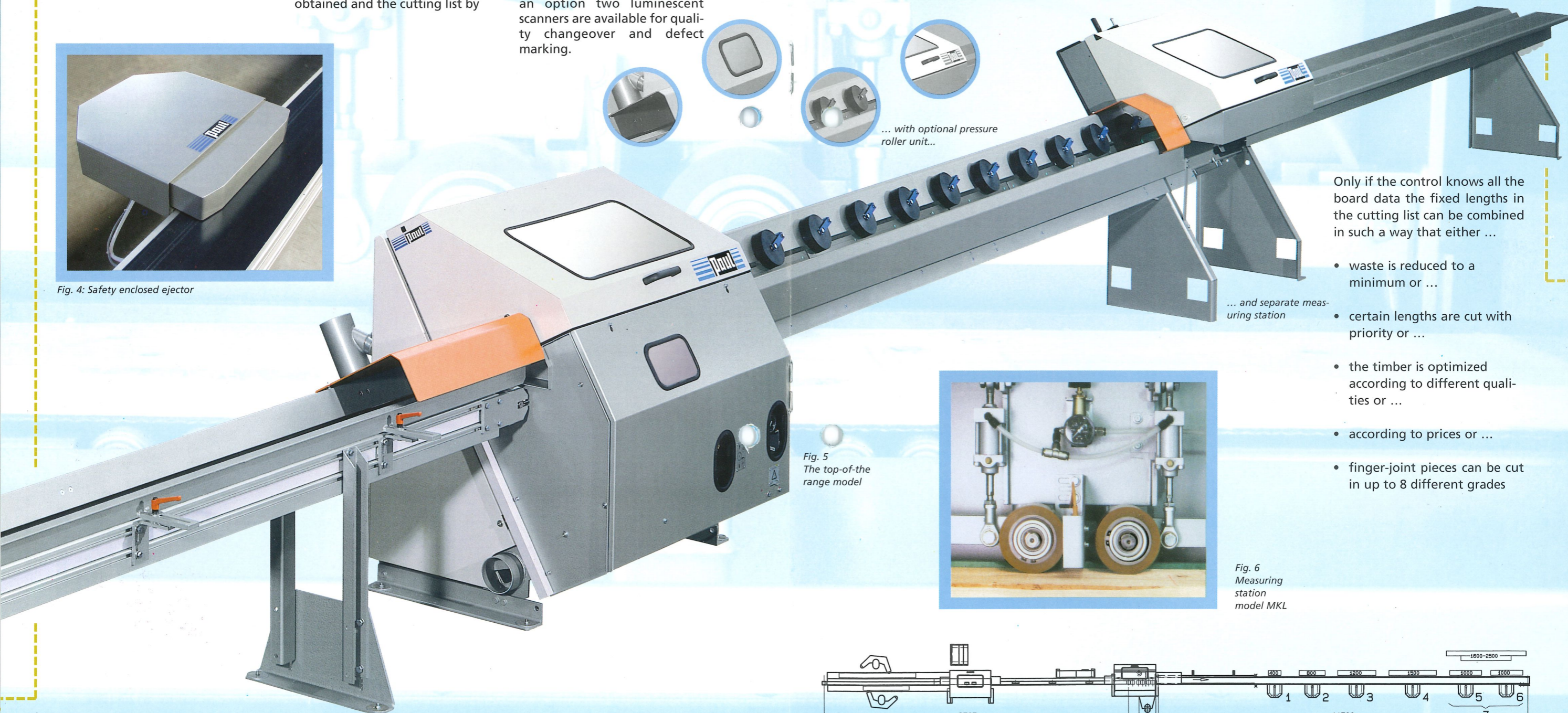

Fig. 5
The top-of-the-range model

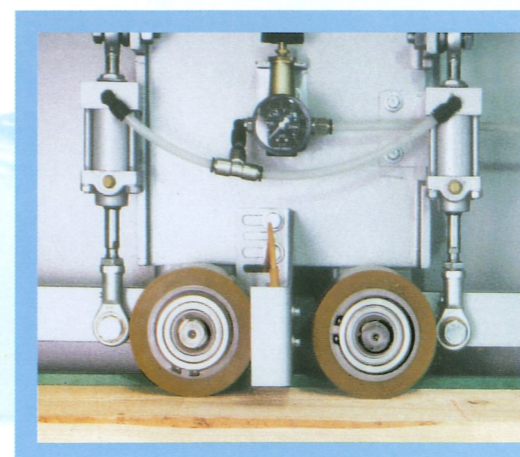
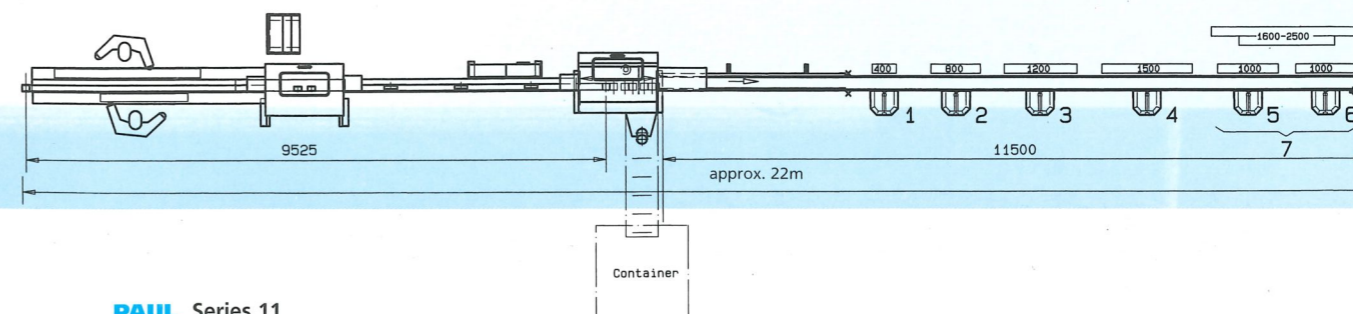

Fig. 6
Measuring station model MKL



Full optimization does not only mean a maximization of the timber yield.

Model 11 KE

for automatic defect cutting and cutting to length from a cutting list

This cross-cut station is equipped with a luminescent scanner for cutting out defects that have been marked with crayon lines. Clear pieces between defects are cut according to preset cutting lists (depending on the control version provided up to 40 cutting lists can be programmed). Normally the machine will cut the longest possible preset length.

Defects are marked with a special crayon. According to the number of defects to be cut out, several markers are required to ensure that the machine is continuously fed with timber. Standard infeed is equipped with two marking stations.

Up to 8 different timber grades can be marked via code lines and it is possible to cut fixed lengths and finger-joint lengths at the same time.

Fig. 7: Detail of model 11

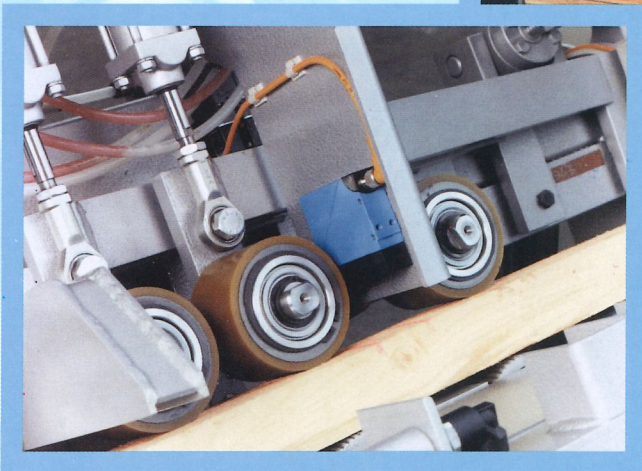
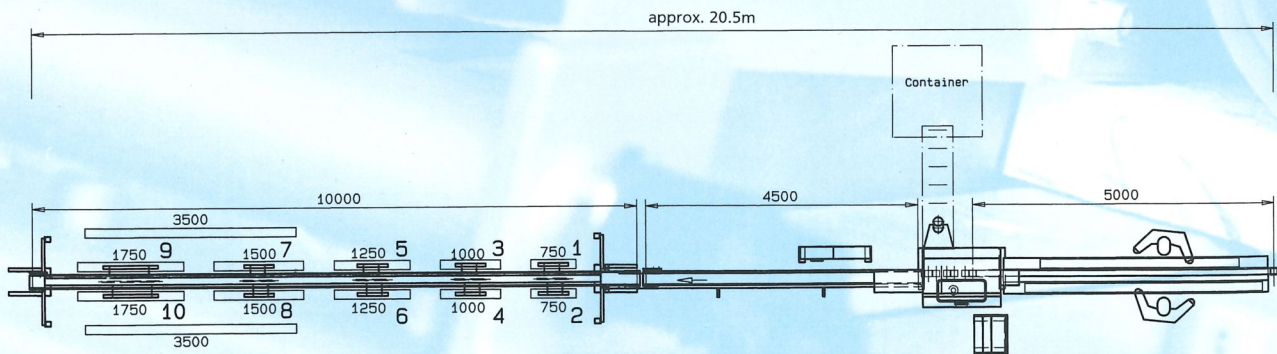

Fig. 8: Defect marking on model 11KE



Model 11KE is used with a NCK-1 or optional MAXI control

Model 11 E

for automatic cross-cutting

according to a cutting list without defect removal

Model 11E automatically cuts the timber according to a preset cutting list. Normally it will cut the longest possible preset length that can be taken between the beginning and end of the timber. Any remaining piece left over will be cut into the next possible longest length ... etc. up to the end of the board (= partial optimization). Defects are not considered.

Model 11E is preferably used in the production of cases and pallets where no defect cutting is required. A further increase in the efficiency of production is achieved by the automatic destacking unit VacuSpeed and the SA-20/SA-25 auto stackers.

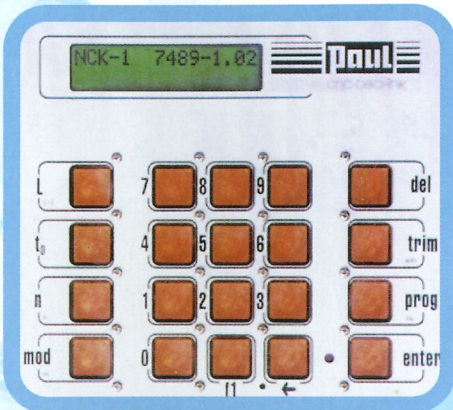

Fig. 9: NCK-1 Control

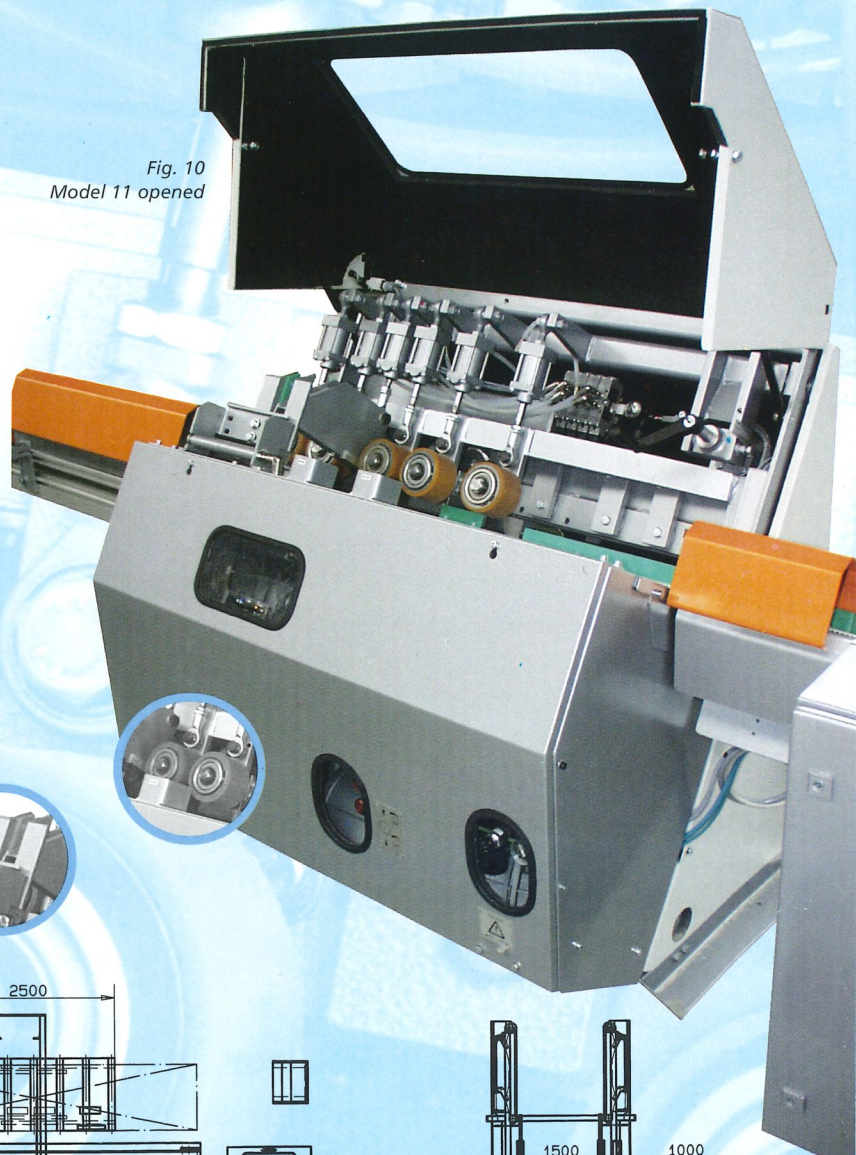
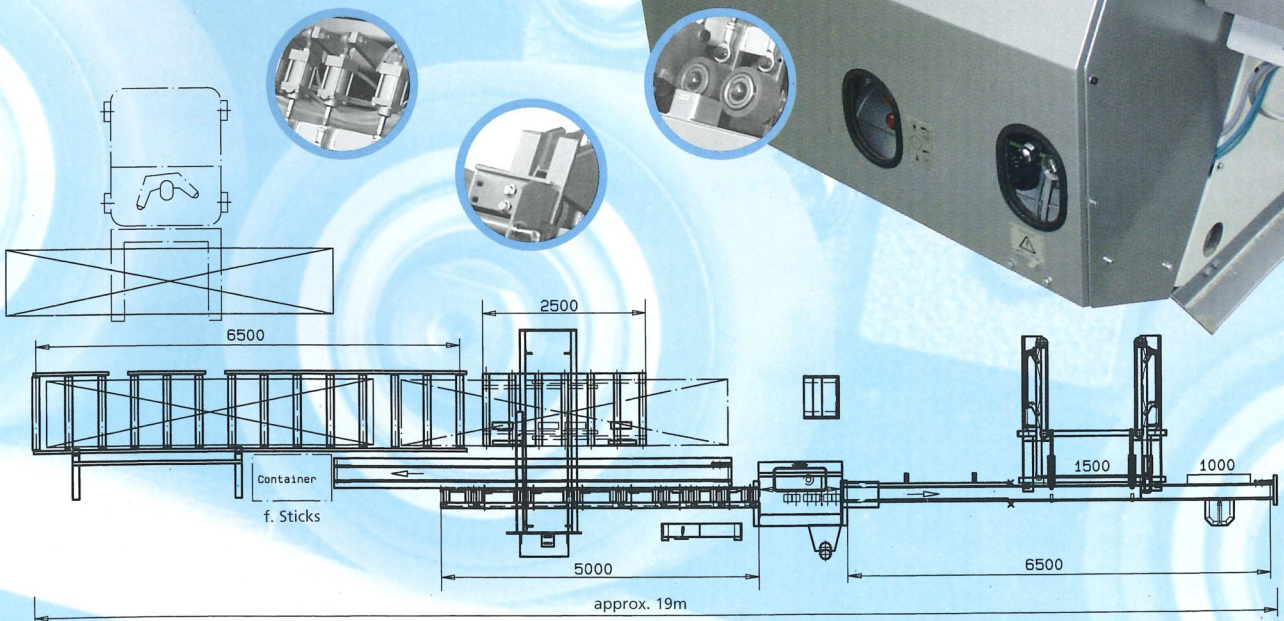

Fig. 10
Model 11 opened



The version including auto infeed length identification is also available with full optimization

Options

Special features and peripheral equipment for an increased efficiency of production

- **Automatic destacking**
"VacuSpeed"
- **Automated handling**
Buffer feeding systems
- **Distribution systems**
to several cross-cut saws
- **Auto stackers**
SA-20/SA-25
- **Width measurement**
Triangulation measuring system
- **Ink-jet printer** for letter or color code printing on top or bottom face and/or end face of the cut pieces
- **Pressure roller unit**

Sorting units

- ejecting to one side only using pneumatic ejectors
- right/left sorting: allows twice the number of sorting stations versus one-side sorting with the same conveyor length
- compact cross-belt sorting for limited floor space

Automatic defect identification

The PAUL Series 11 CNC cross-cut systems can be equipped with any of the scanners available on the market. The MAXI 4.0 control provides an interface for the data exchange with the scanner.



Fig. 11:
Buffer feeding system



Fig. 12:
Scanner

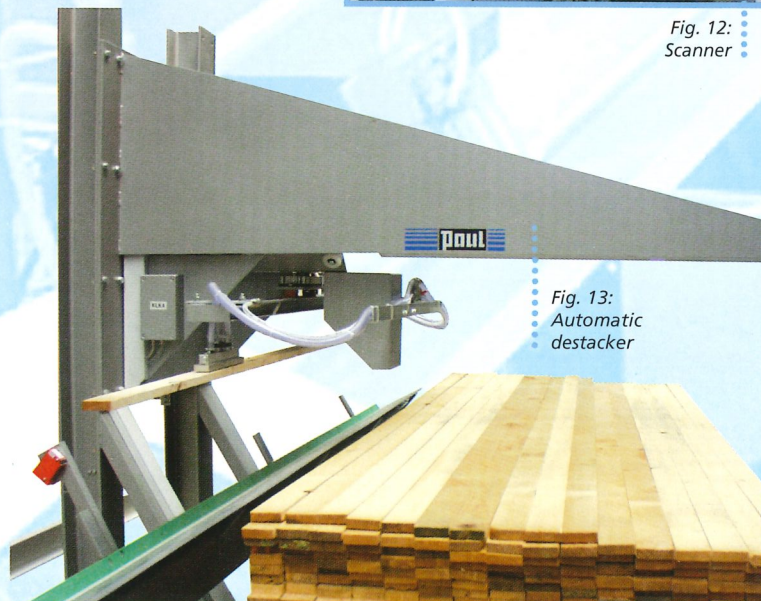

Fig. 13:
Automatic destacker



Fig. 14:
Auto stacker
SA20-SA25



Fig. 15:
Ink-jet prints

Fig. 16:
Cross-belt sorting unit



Fig. 17: Sorting belt



Equipment / Types

11 E	■	X	■	○	X	□	X	NCK-1
11 E	■	○	■	●	○	□	□	MAXI 4.0
11 KE	■	■	■	X	X	□	X	NCK-1
11 KE	■	■	■	X	X	□	□	MAXI 4.0
11 MKL	■	■	■	■	■	□	□	MAXI 4.0

■ as standard

□ option

X not available

● with auto infeed length identification (option) and MAXI 4.0

○ with defect scanner, standard

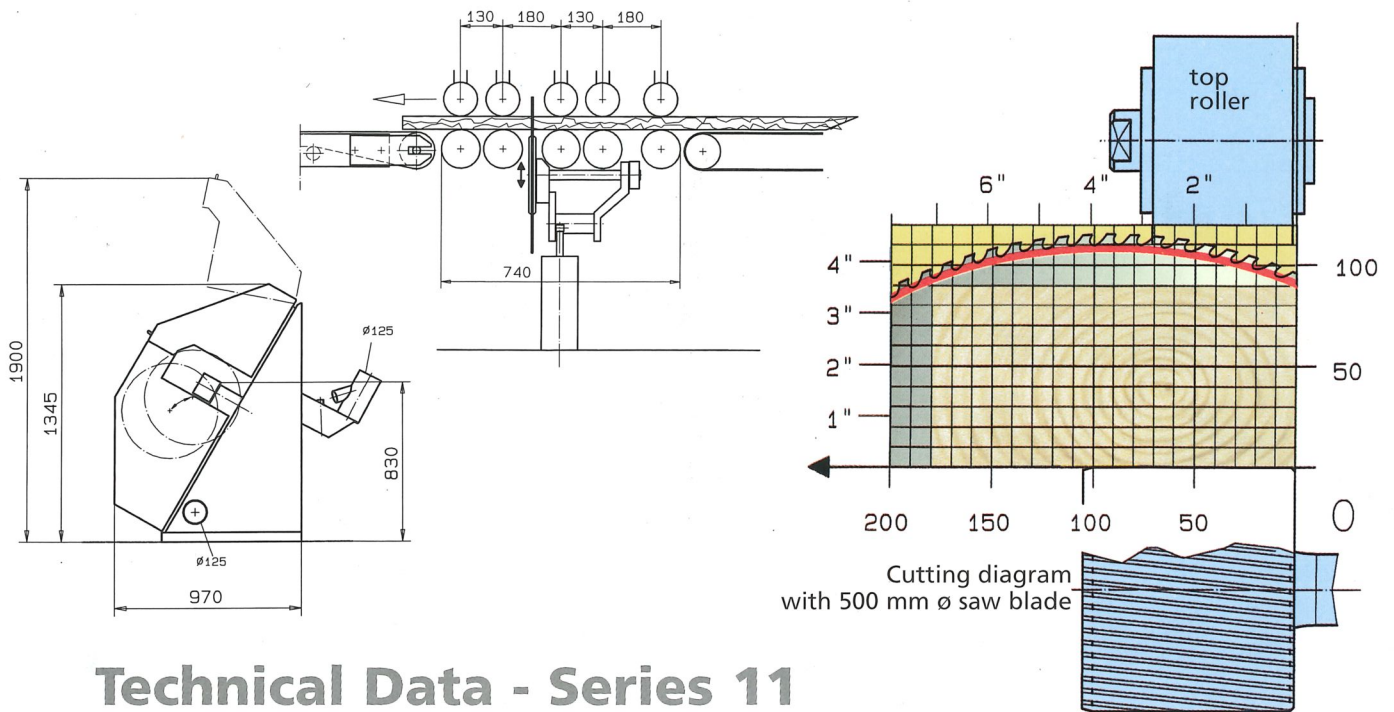

Technical Data - Series 11

Technical Data

Saw motor	kW	5.5
Feed motor (option)	kW	4 (6)
Powered bottom rollers		5
Min. cutting time (option)	sec	0.23 (0.17) ¹⁾
Max. feed speed	m/sec	3.35
Max. acceleration	m/sec ²	25 (35)
Max. number of cuts	per min.	150
Speed of saw blade	rpm	4350
Dust outlet diameter	mm	2 x 125
Dust extraction requirement	m ³ /h	1800 - 2600 ²⁾

Basic Timber Data

Min. infeed timber length 11KE (11MKL)	mm	300 (450)
Max. infeed timber length	mm	6500 / 9500 ³⁾
Timber thickness	mm	12-90
Min. timber thickness (with special sensors)	mm	3
Timber width	mm	30 - 180
Min. timber cross section	mm	12 x 30
Max. timber cross section	mm	180 x 45 / 130 x 75 / 90 x 90
Min. cut length	mm	130 ⁴⁾ / 250
Min. cut length at end of timber	mm	180

1) with servo-controlled cutting stroke
3) with partial optimization

2) at air speed 20 - 30 m/sec
4) with clamping device