

# CONCEPT

Automatic  
double-end  
tenoner

# 2000

 **scm**



# CONCEPT 2000

**Automatic  
double-end  
tenoner**

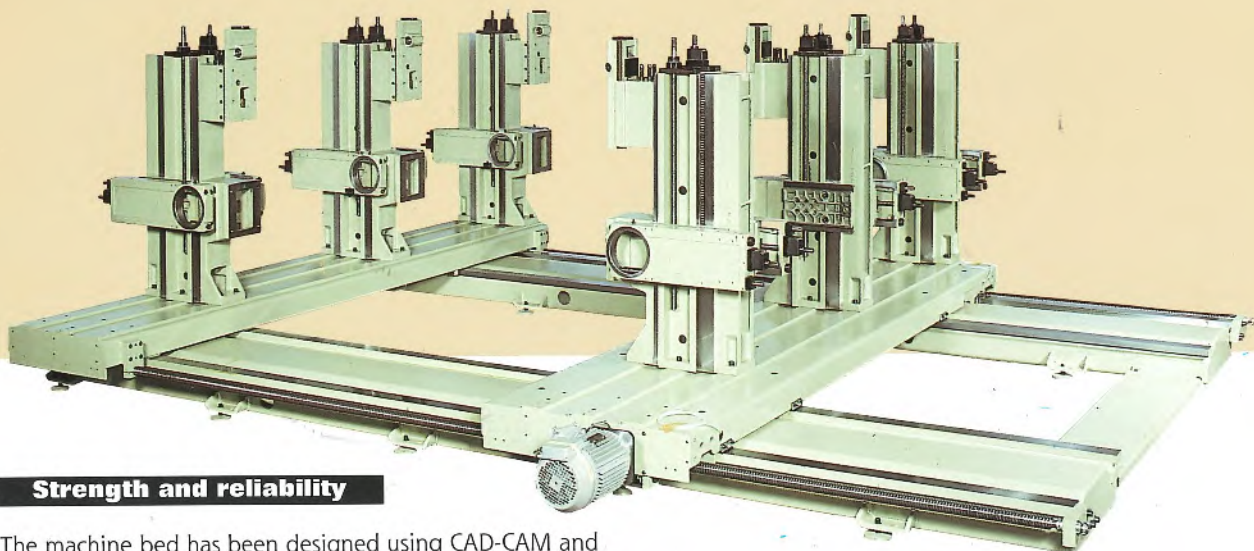
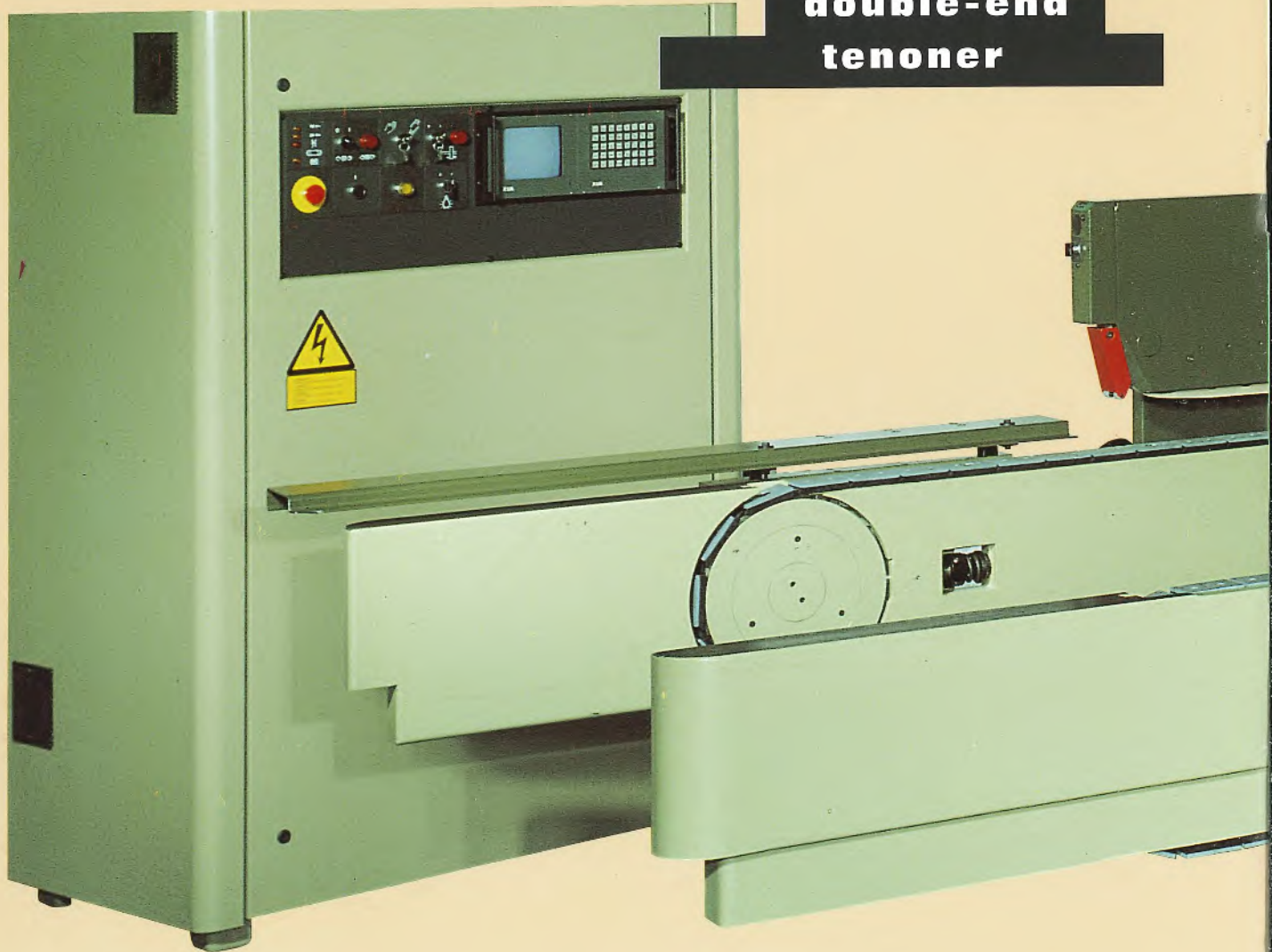

## **Strength and reliability**

The machine bed has been designed using CAD-CAM and other advanced techniques to ensure maximum strength and reliability.



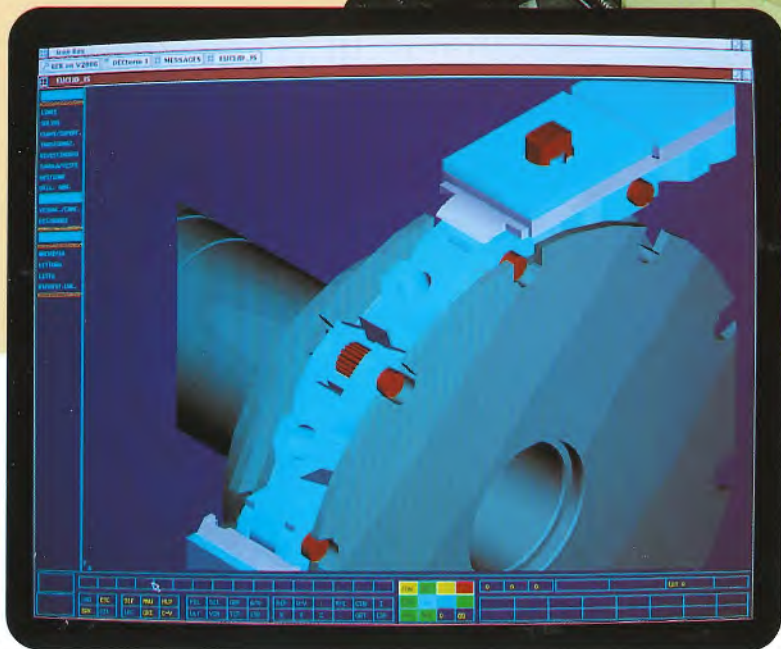
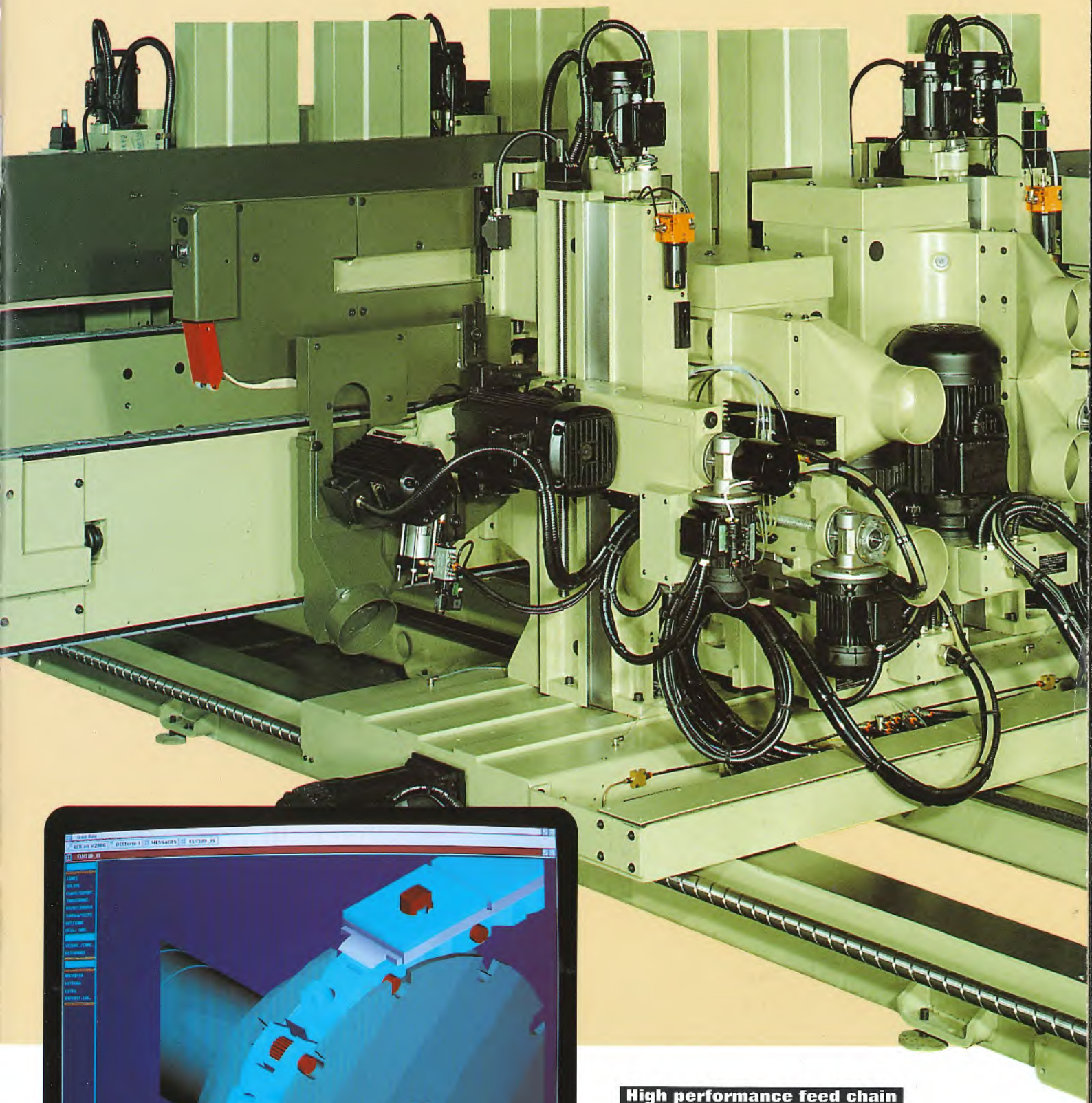

### **High performance feed chain**

The new high-performance chain guarantees a reliable, high precision feed.





**Advanced numeric control units**

Fitting the optional numeric control unit provides the maximum versatility and flexibility and enables the machining of moulded shapes.

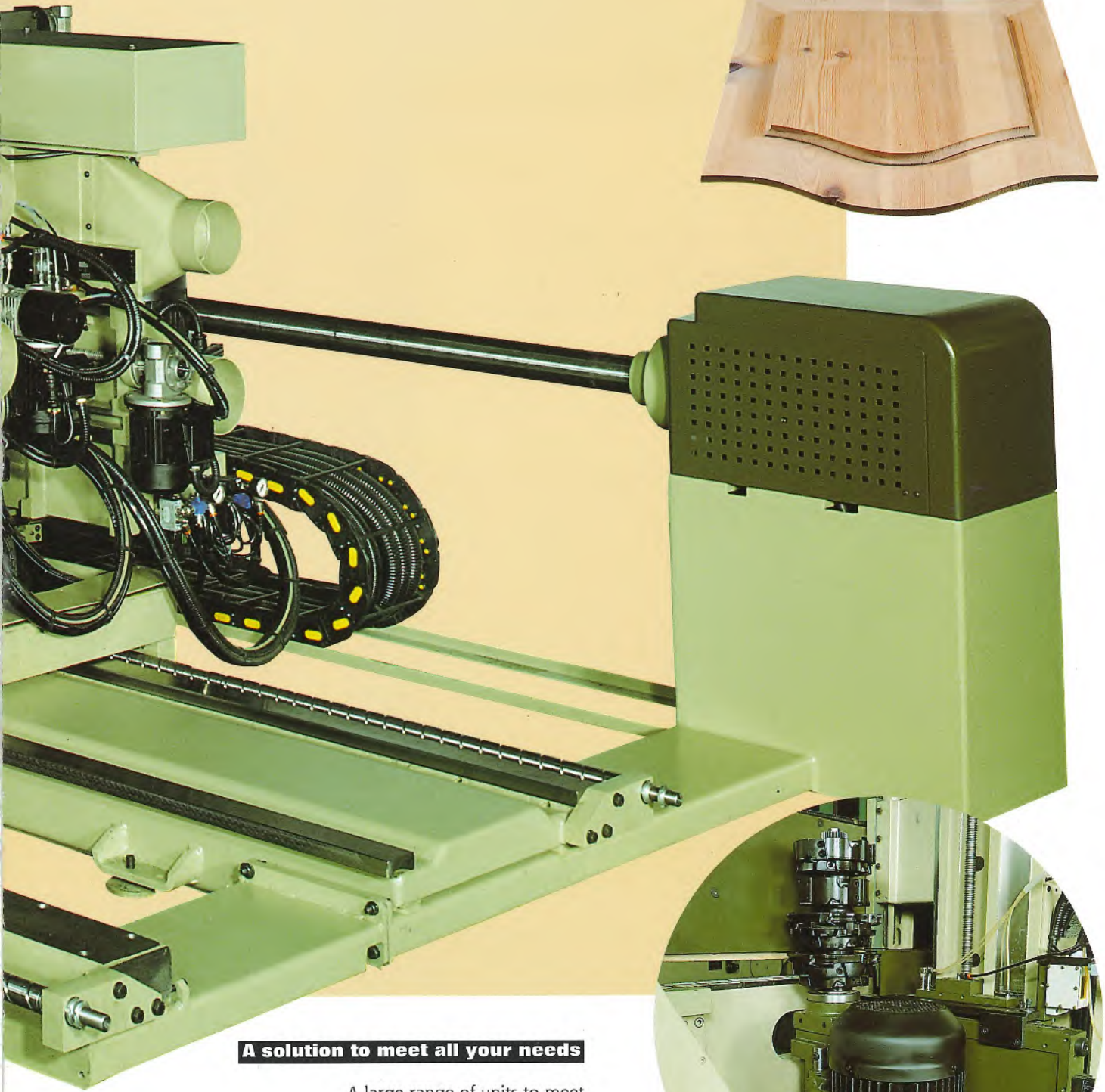

**A solution to meet all your needs**

A large range of units to meet all your machining needs.





# CONCEPT 2000

## A quality choice

Quality in design, manufacture and testing: fundamental priorities for a successful machine.

SCM tenoners are designed with CAD-CAM, manufactured with CNC machine tools and thoroughly tested by specialists.





# Solid and practical for top performance

## High-precision feed system

The CONCEPT 2000 feed system has been designed to rigorous standards to ensure uncompromising precision and durability.

**1** - A strong, ribbed, tubular section steel base; heat treated to ensure long-lasting stability.

**2** - High-resistance steel slideways with hardened, ground and polished surfaces; the combination of one cylindrical and one flat guide guarantees smooth travel without any play.

**3** - Feed chain made up of strong, sintered (high pressure compressed) steel links, hardened/ground steel pins and long-life lubricated, roller bearing joints. The belts have oil mist lubrication as standard.

**4** - Wear-resistant synthetic alloy pads with a lip protection to prevent the entry of dust; pads have a steel core to provide the maximum impact resistance.

**5** - Strong referencing stops. These can be fitted with the optional automatic control to enable raising and lowering of the stops to different heights (12, 18 and 30 mm) from the control panel.

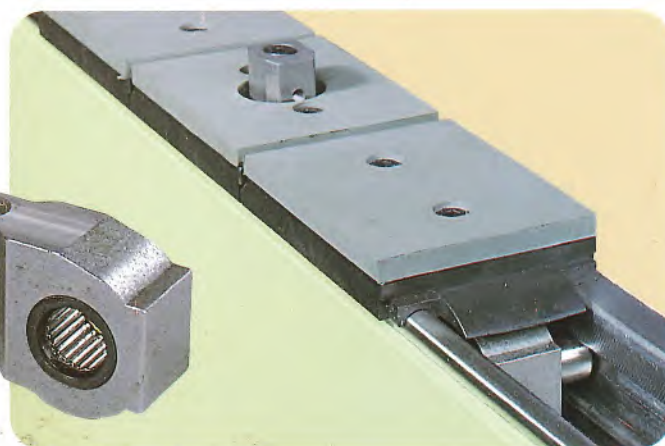
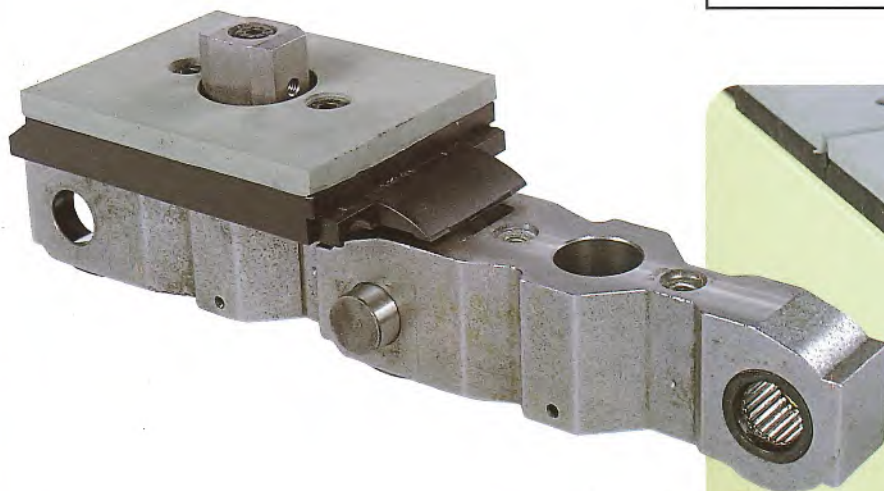
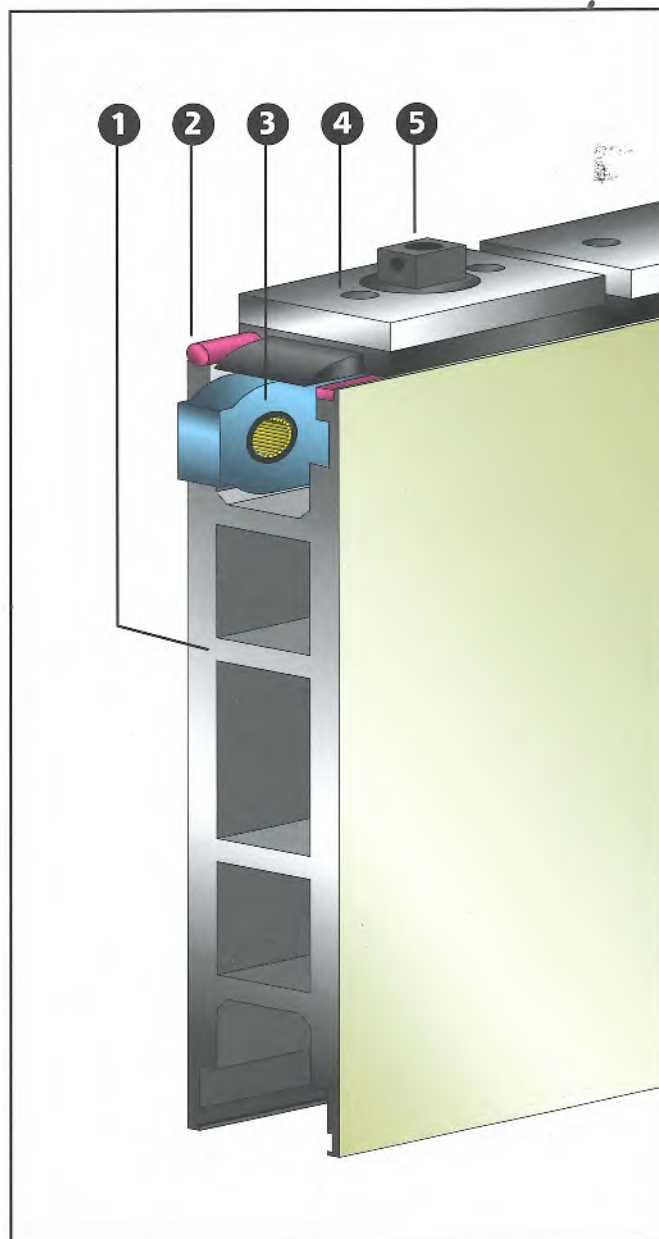



## Strong, reliable structure

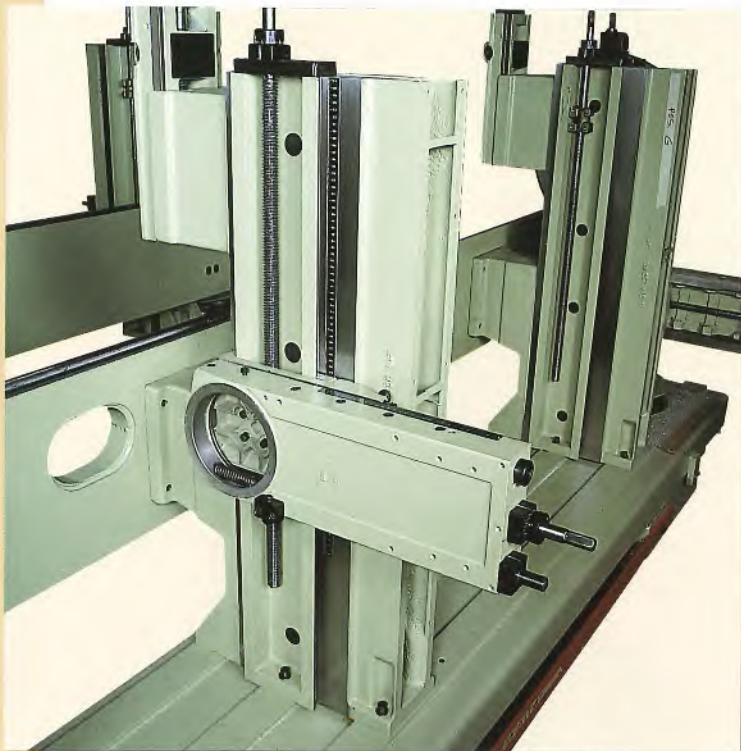

### Uprights

- in strong, ribbed, tubular cast-iron; generously sized to provide a large, solid support and eliminate resonance and vibrations.



### Hold-downs

- in steel with belts in special rubber to enable application of the ideal pressure on all workpieces.
- can absorb a difference in level of 12 mm on the same workpiece.
- can traverse crossways (optional 35 mm) to enable machining even over the feed chains.

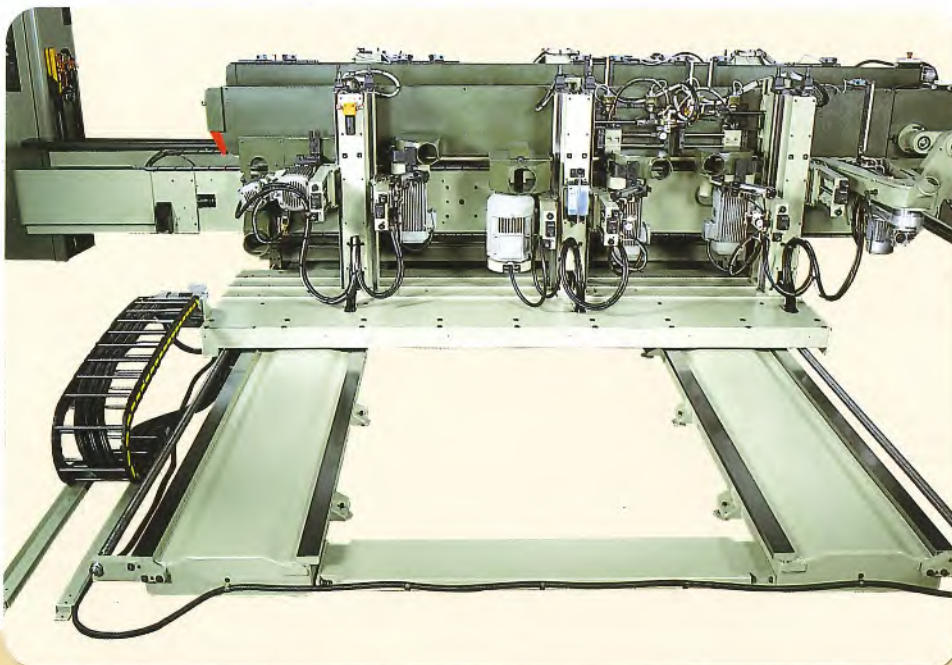
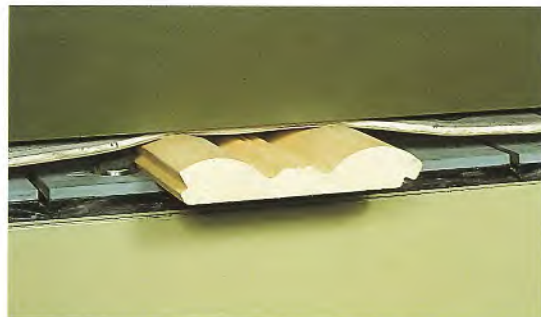

### The base

- in tubular section, steel ribbed for strength
- treated and normalized to prevent all distortion
- large ground slideways for smooth operation of the mobile upright
- lubrication pump for the slideways as standard.



# A solution to all your needs

## Working units

Scorer-hogger unit

Twin hogger

Belt-driven spindle moulder

Automatic relisher

Corner machining unit

Trimmer-beveller

Boring units

Unit for machining inside  
feed belt

TC60/S

TC80/S

Rebater for 45° glazing bead

Belt sander

Disc sander

Twin belt edge sander

Multi-stack spindle

CNC shaping units

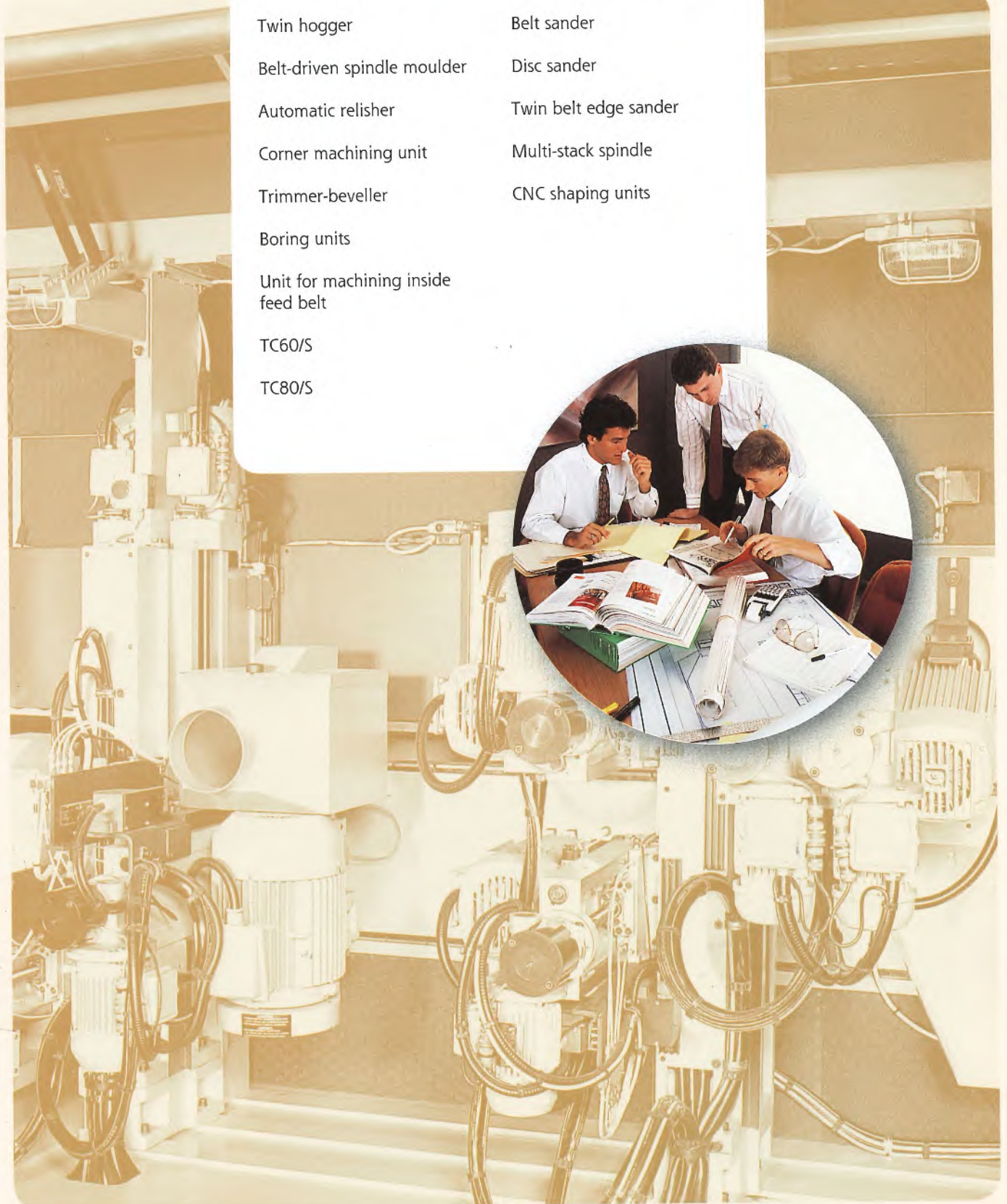



## Working units

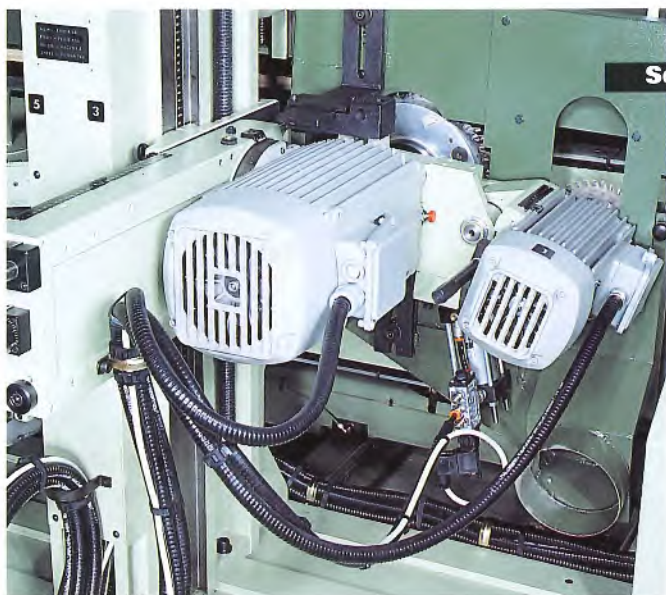

### Scorer-hogger unit

A versatile combination of two units for squaring panels (in chipboard, laminate or MDF) or rebating solid wood components for doors, windows and frames.



### Twin hogger



Two hogger units coupled for squaring panels; recommended for large series production at high feed speeds. Twin hogs should be used in conjunction with the "timed" anti-chipping unit.

### Belt-driven spindle moulder

Ideal for heavy duty use and offers high performance combined with quality and power.

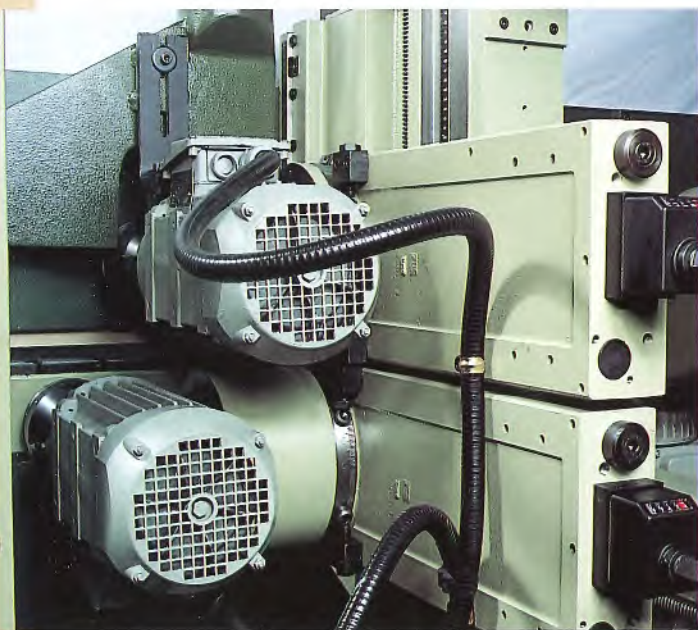
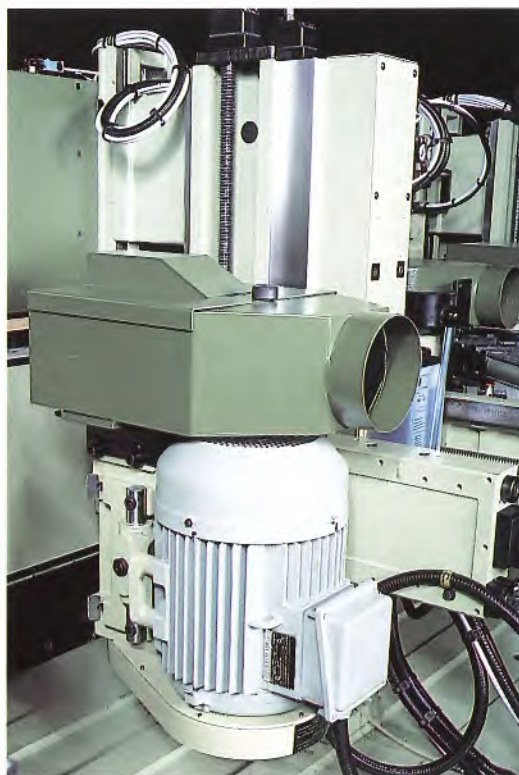



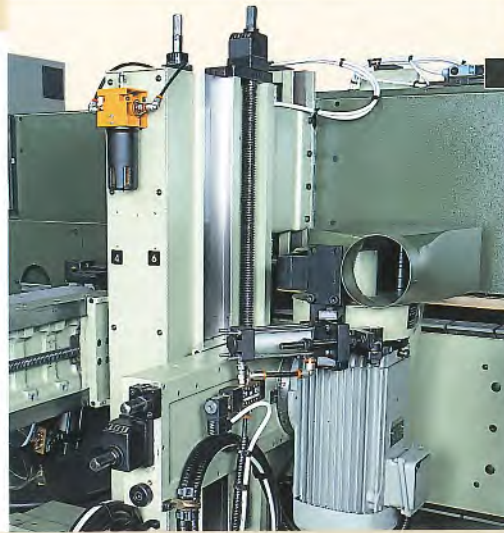
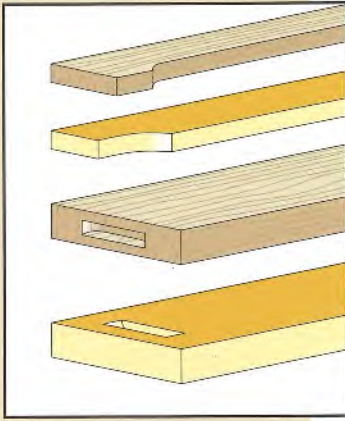

**Automatic relisher**

Enables the use of small diameter tools at 7000 rpm in timed machining operations. Will machine at any angle.

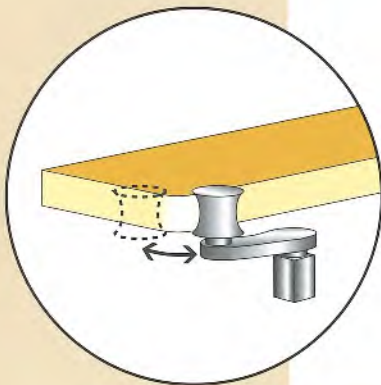

**Corner machining unit**

Enables rounding and bevelling with mechanical followers.

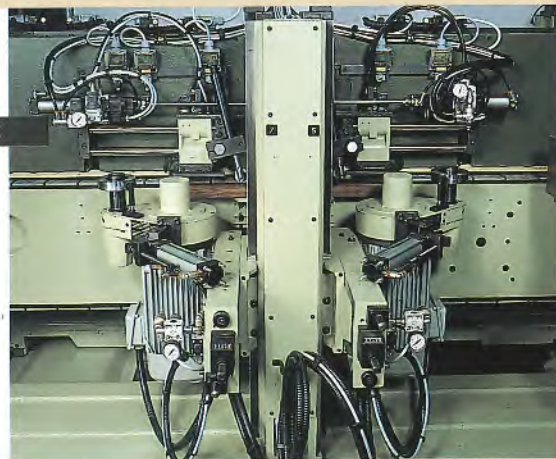

**Trimmer-beveller**

Bevelling copied with followers from the reference surface.

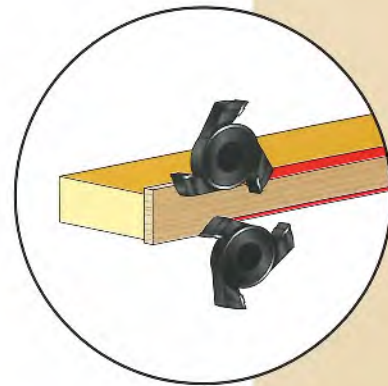
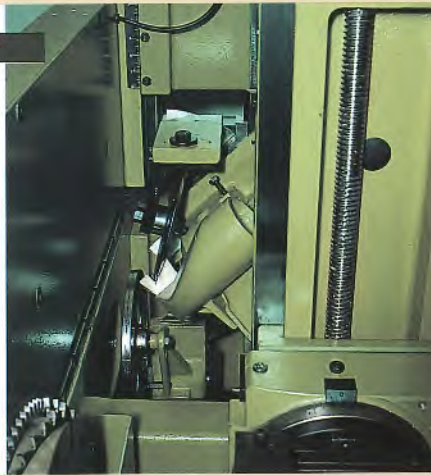

**Boring units**

A wide range of boring units are available. All guarantee precision boring thanks to a workpiece clamping and follower system. Designed for drilling furniture, frames, chairs, doors and many other components.

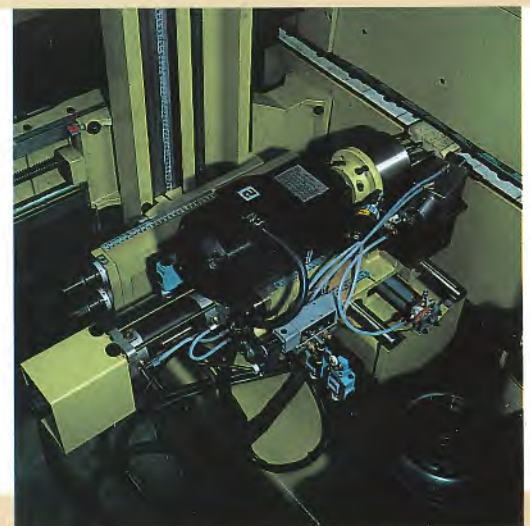
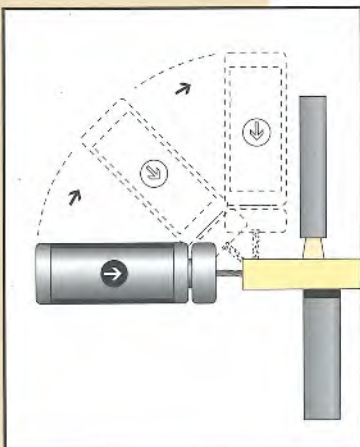



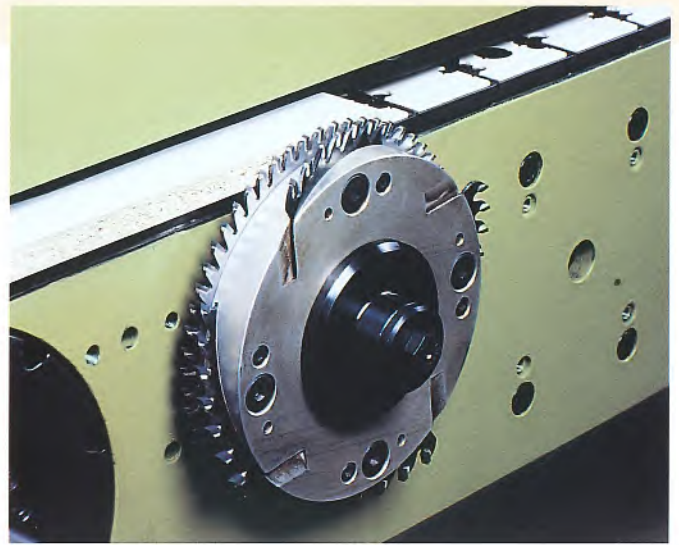
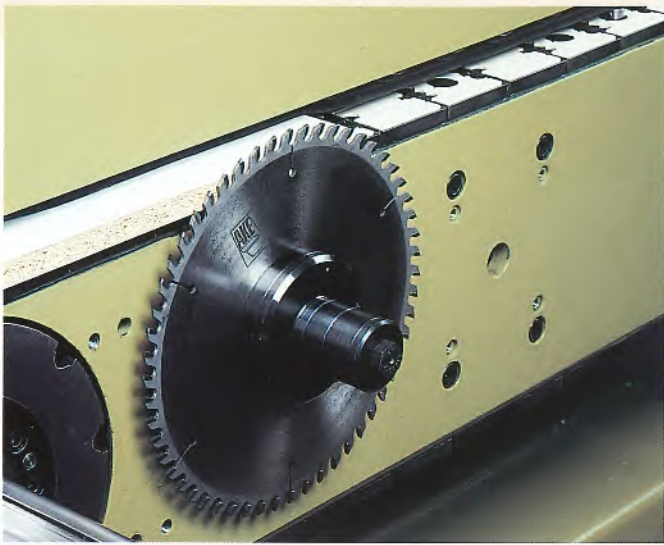

**Unit for machining  
inside the feed belt**

Extension spindles (available for direct drive units and belt-driven spindle moulder) for machining operations inside the feed belt. This enables the use of cutting, grooving and scoring tools on the section of the workpiece between the feed belts.

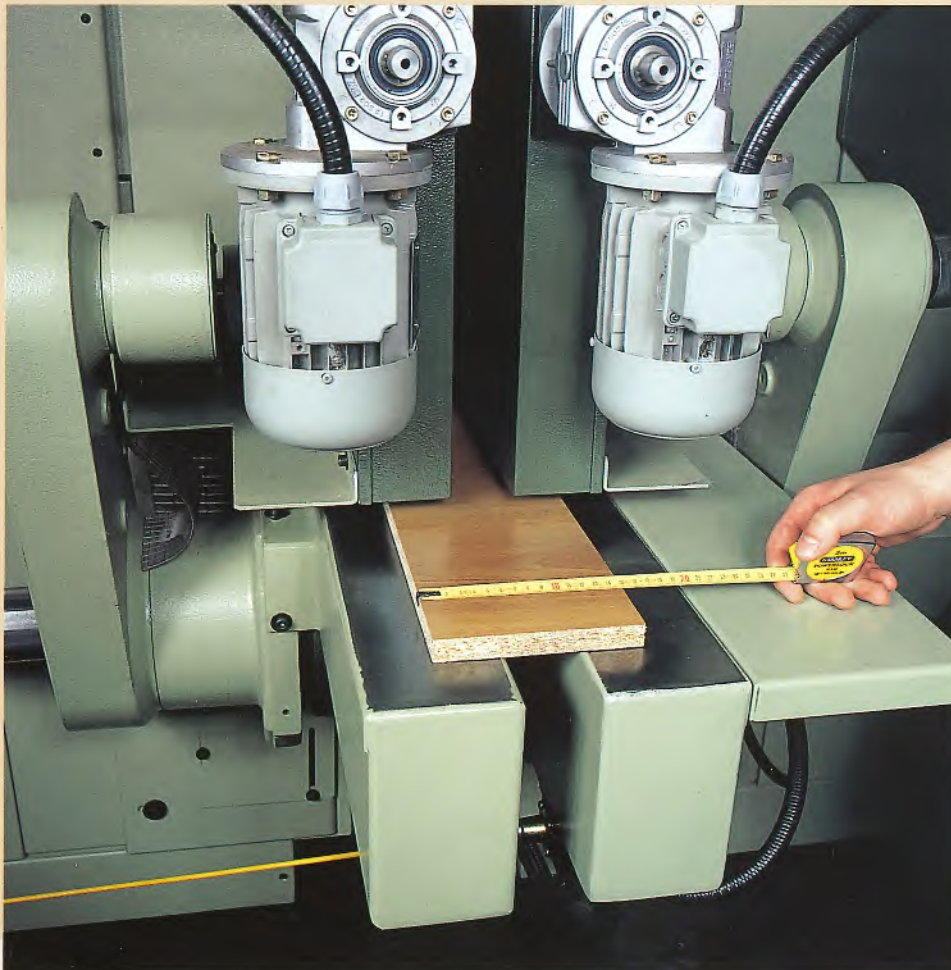
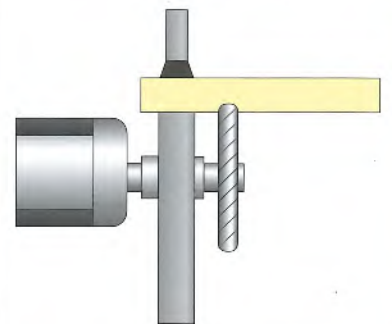
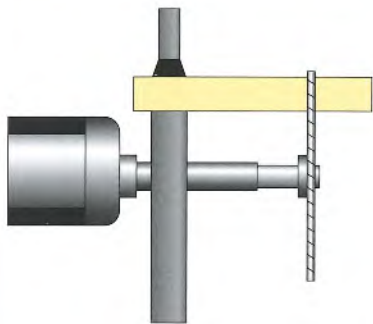

**Concept 2000**

Concept 2000 will machine workpieces on both feed belts down to a minimum width of 150 mm. Narrower widths can be machined by performing two passes on one feed belt only.



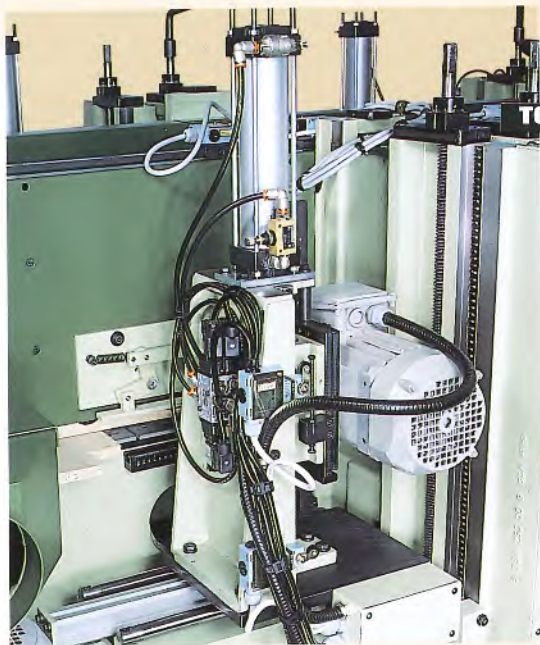

**TC 60/S**

Unit for machining closed tenons on door, window and blind transoms.

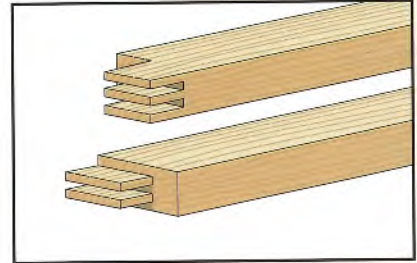

**TC 80/S**

Unit for machining double-end tenons on the central transoms of doors, windows and blinds.

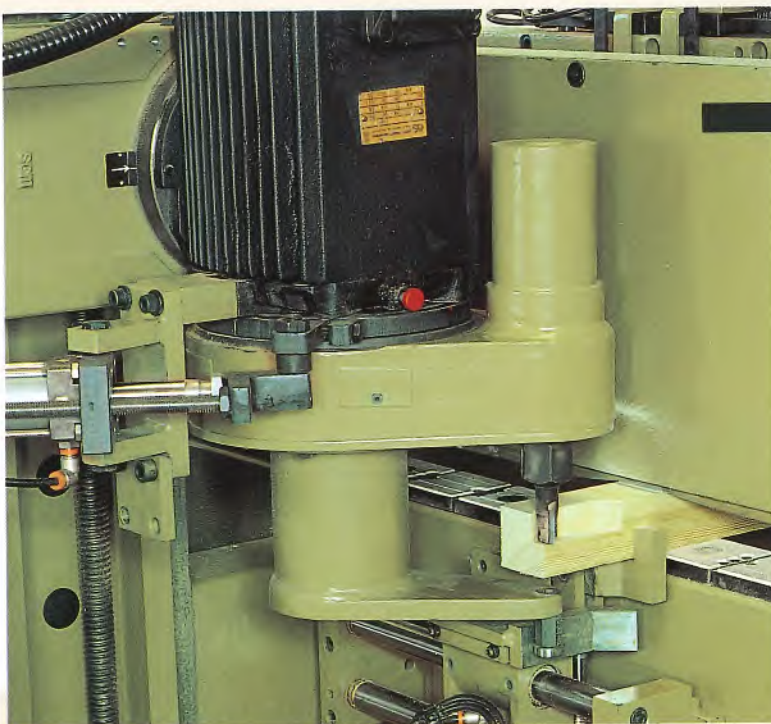
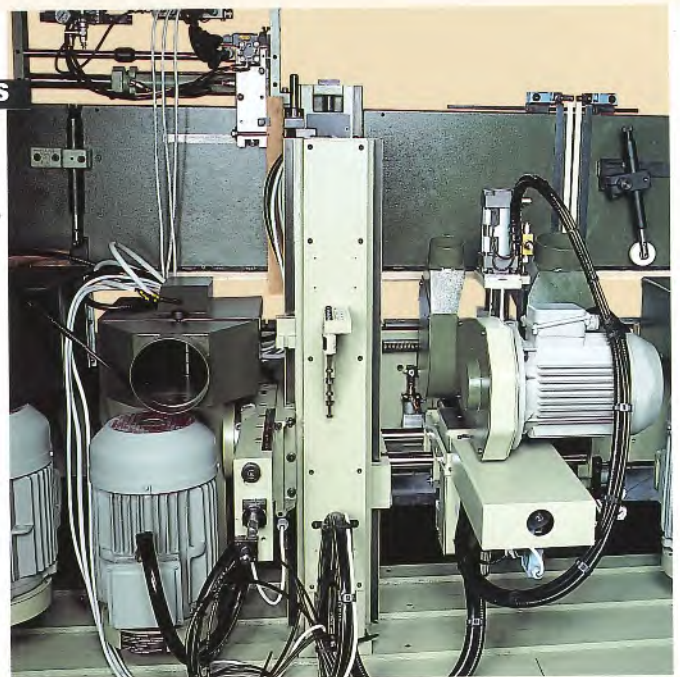
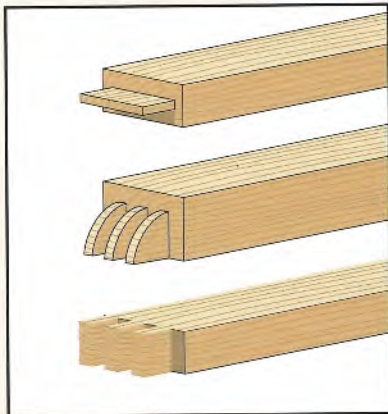

**Rebater**

Unit for cutting 45° glazing bead on window frame components.

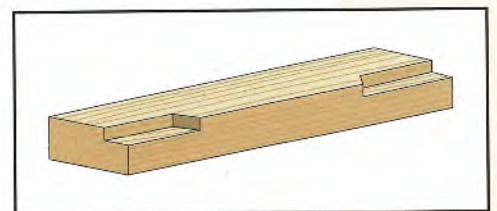



## Sanding units

Concept 2000 can be fitted with a variety of sanding units to provide a high quality finish in a single pass. The sanding units shown can be used singly or together on complex machining jobs.

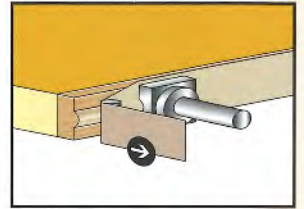
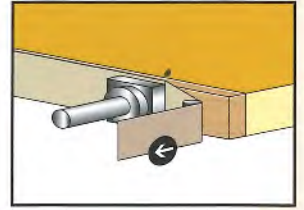
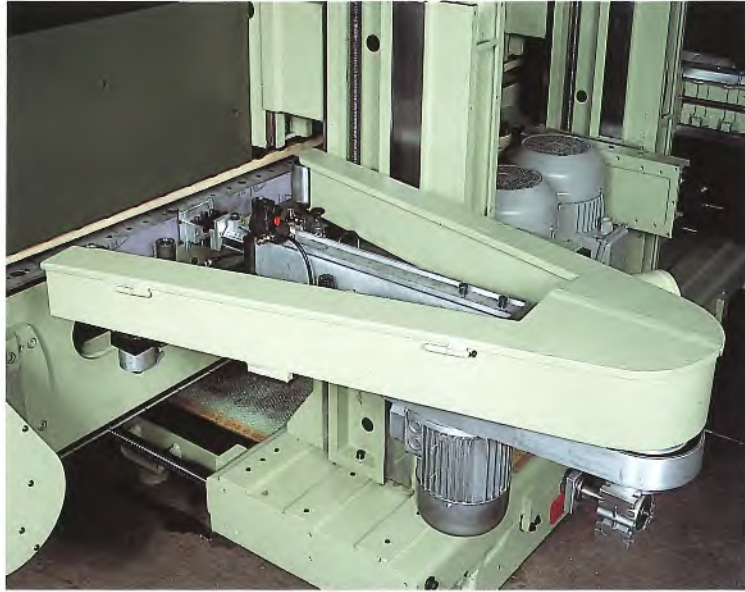

### Belt sander

Versions available for sanding flat or shaped edges.



### Disc sander

Version also available with continuous speed adjustment by static inverter.



### Twin belt edge sander

Smooths the two upper and lower edges of the workpiece.

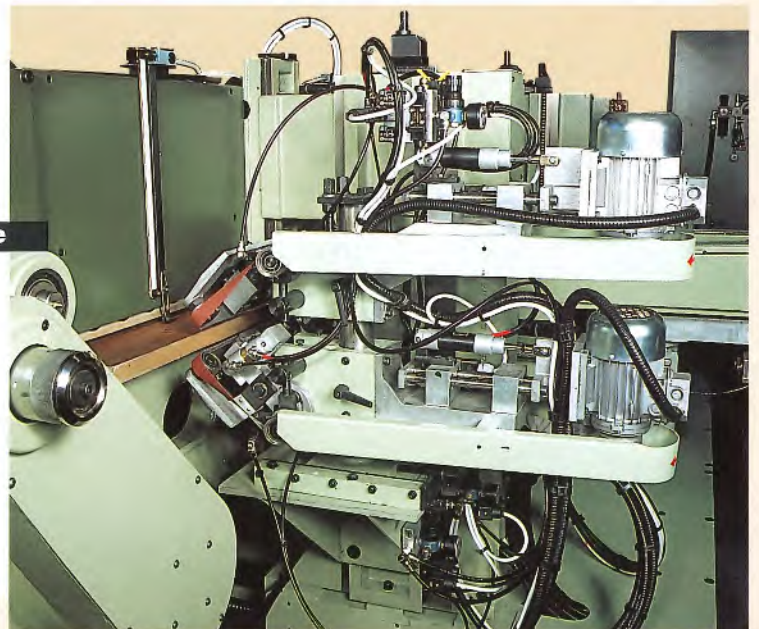
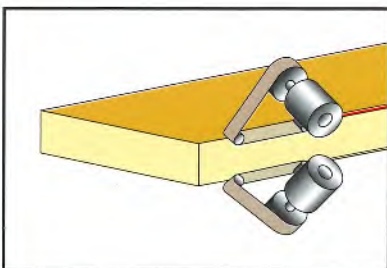



## Multi-stack spindle unit



Toupie H = 620 mm.

For over 10 years SCM has been producing multi-stack units for tenoning, squaring and shaping. Units are available with a working height of 320 mm and 620 mm (with spindle counter support). All multi-stack units have 50 mm diameter spindles with a twin pair of ISO P4 class bearings pre-loaded from the chuck side.



Toupie H = 320 mm.

### Jolly/L automatic anti-chipping unit

Maximum tenoning flexibility with the Jolly/L unit connected directly to the tenoner unit. No adjustment between one tenon profile and another is required.



Spindle moulder H = 620 mm with Jolly/L automatic anti-chipping unit.

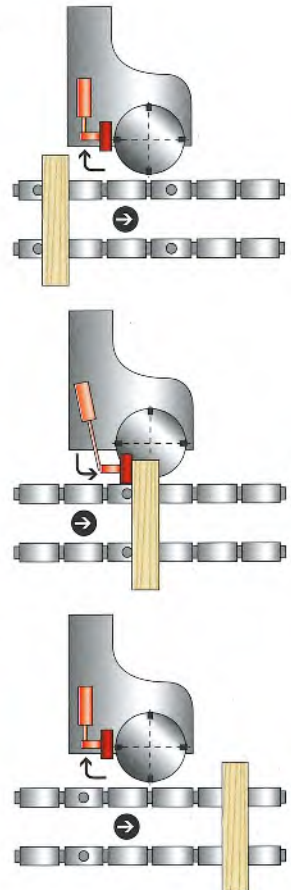



## CNC versions

Concept 2000 can be fitted with Computer Numeric Control units to obtain the maximum flexibility, precision and versatility from the machine.

The CNC unit makes it possible to:

- easily store machining programs (no knowledge of a programming language is required);
- call up and execute programs from memory in a matter of seconds;
- enter the data (prepared in the office) for an entire order from floppy disks (or over the

RS232 serial port) thus reducing set-up errors and down time to the minimum. (available on Control 10 PC unit);

- check machine efficiency and operation in real time using the advanced self-diagnostics system;
- calculate statistics for production time, output and down time.



**Control 10 PC**  
Numeric control unit with industrial personal computer (MS-DOS operating system).



Data entry using bar code reader systems.

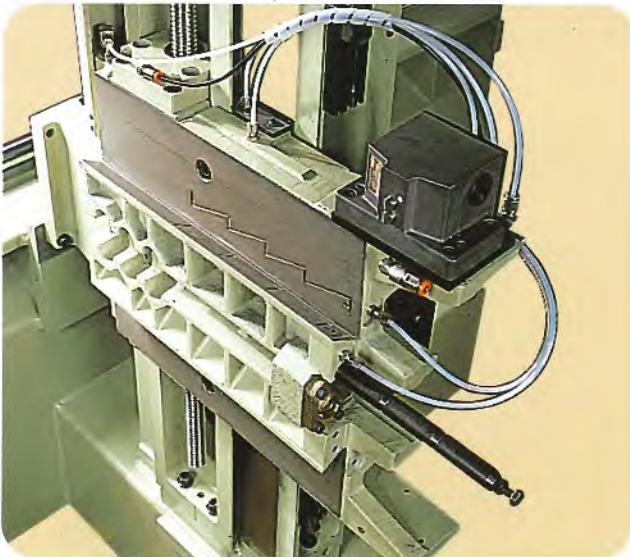

On CNC equipped machines, machining units are driven and positioned by recirculating ball screws and encoders with hundredths resolution; automatic centralized lubrication is also available (optional).

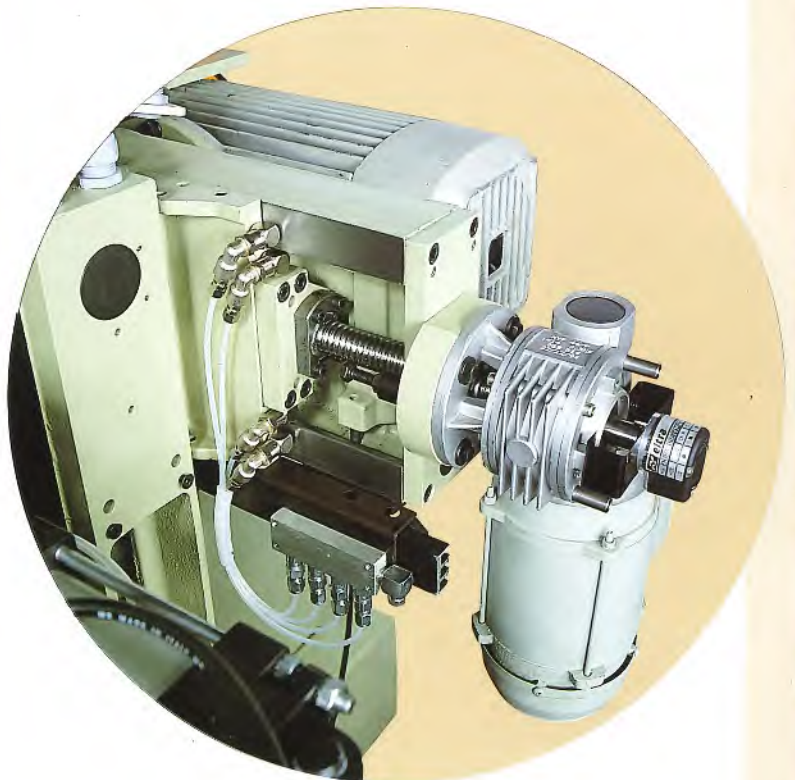



# Copytronic 90

Copytronic 90 is the latest, flexible shaping system for automatic double-end tenoners.

Thanks to the Copytronic 90, Concept 2000 can become a machining centre for producing:

- kitchen cupboard doors

- components for old style furniture
- table tops
- head boards for beds
- components for garden furniture
- wardrobe and kitchen furniture cornices

## CNC shaping system

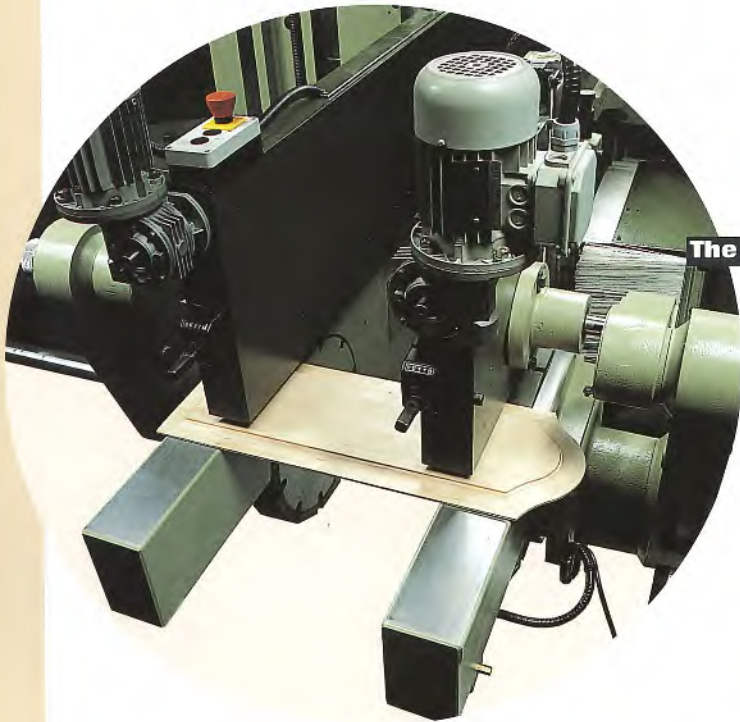

### The competitive advantages of Copytronic 90

- high output rates
- roughing-sanding in masked time
- reduced set-up times at size changeover (thanks to the mobile upright)
- automatic adjustment of machining programs to match workpiece size (family

programming);  
- easy to add to complete machining lines with automated infeed and outfeed.

### 300 PC Computer Numeric Control

- incorporating industrial personal computer (MS-DOS operating system), complete with:
- 14" colour monitor
- 3 1/2" floppy disk drive
- RS232 serial port
- Centronics parallel port for printer.

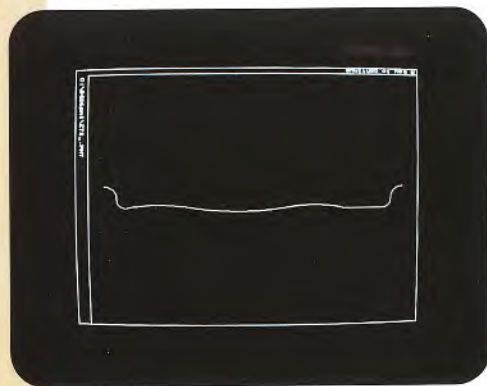

The workpiece being programmed or machined can be displayed and checked on the CNC monitor.





# Copytronic 90

## Programming

Quick and easy. You can start from an existing drawing or sample (method A) or program directly from a drawing generated on a PC with AutoCad (method B).

**A**

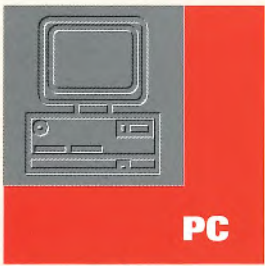

**B**

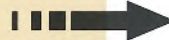
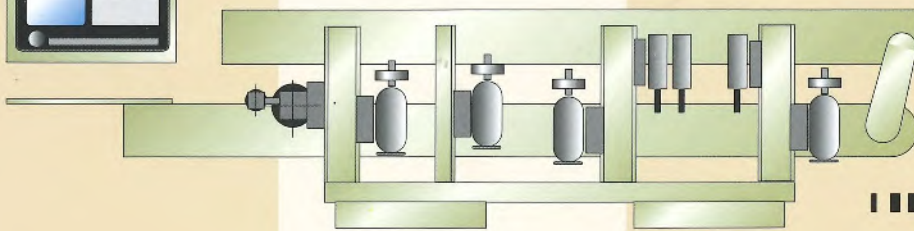
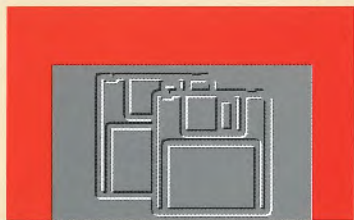
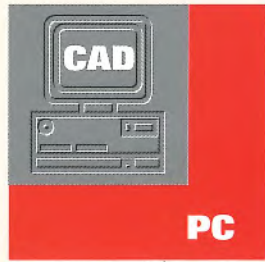



# Copytronic 90

## Working units

Copytronic 90 is available with working units designed and manufactured to guarantee the maximum performance.

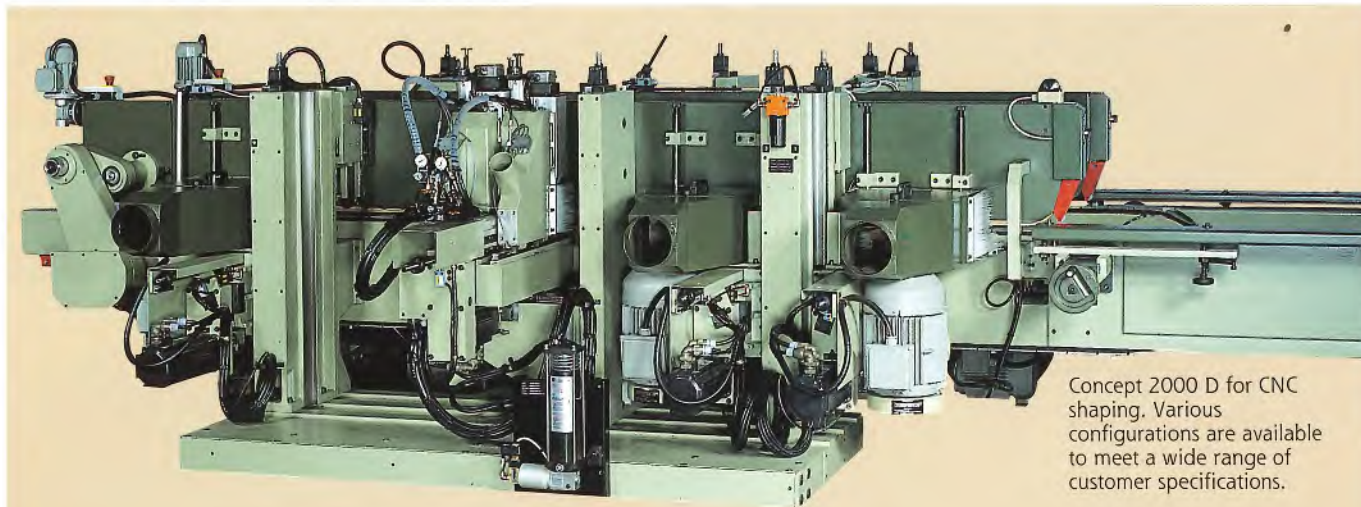

Concept 2000 D for CNC shaping. Various configurations are available to meet a wide range of customer specifications.



Electro-chucks for high-speed routing (18000 rpm with 7.5 kW inverter) for a high grade finish even when machining with small diameter tools.



An optic fibre sensor at the machine infeed detects and measures the workpiece being fed in. Special CNC software automatically adjusts the machining program to match workpiece dimensions.

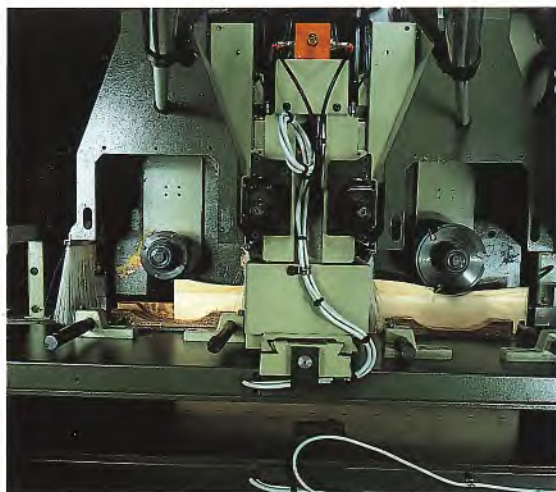

Spindle moulders for routing where heavy stock removal (13 kW max.) is required. Used for left and right roughing and finishing.







Corner rounding units. Fitted with electro-chucks (7.5 kW at 18000 rpm) with speed adjustment by static inverter. Available in routing and sanding versions.

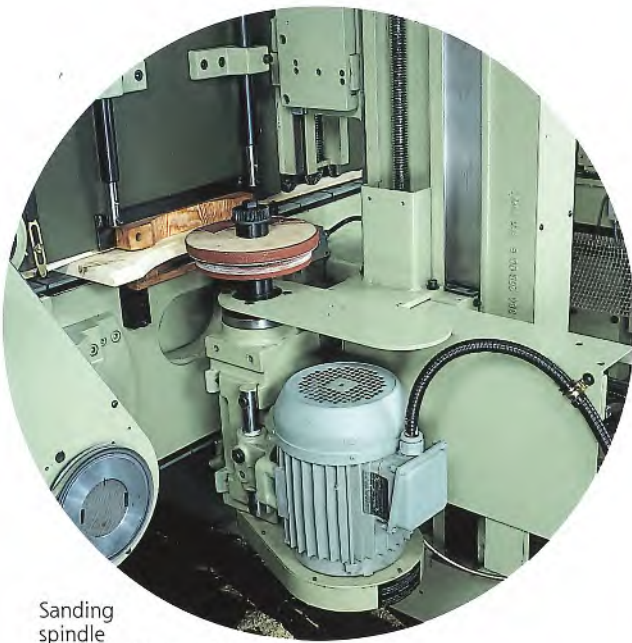
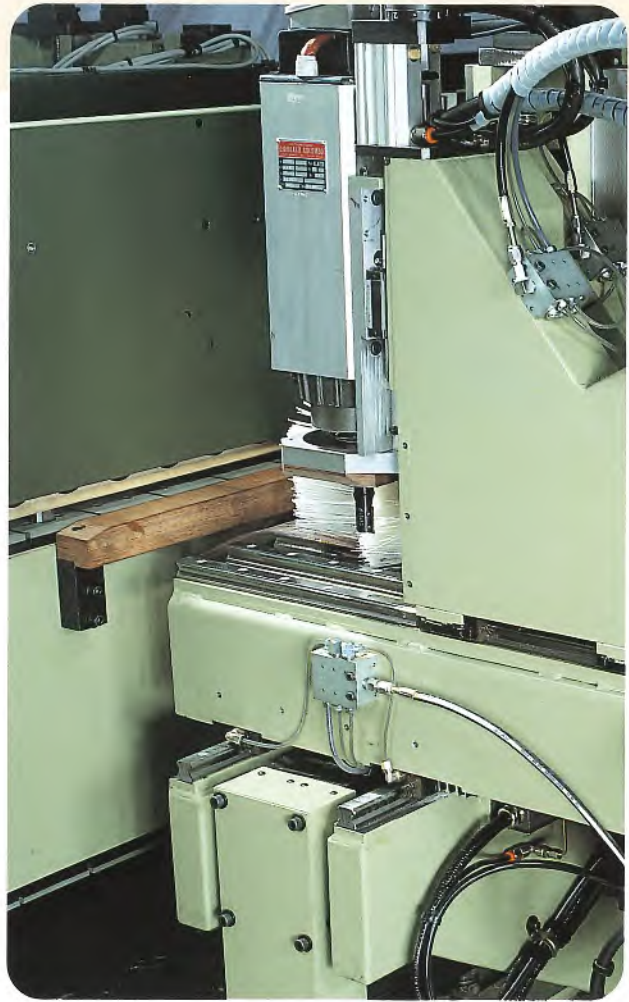

Sanding spindle moulder. Also available with speed adjustment by static inverter; both discs and shaped pads can be used.

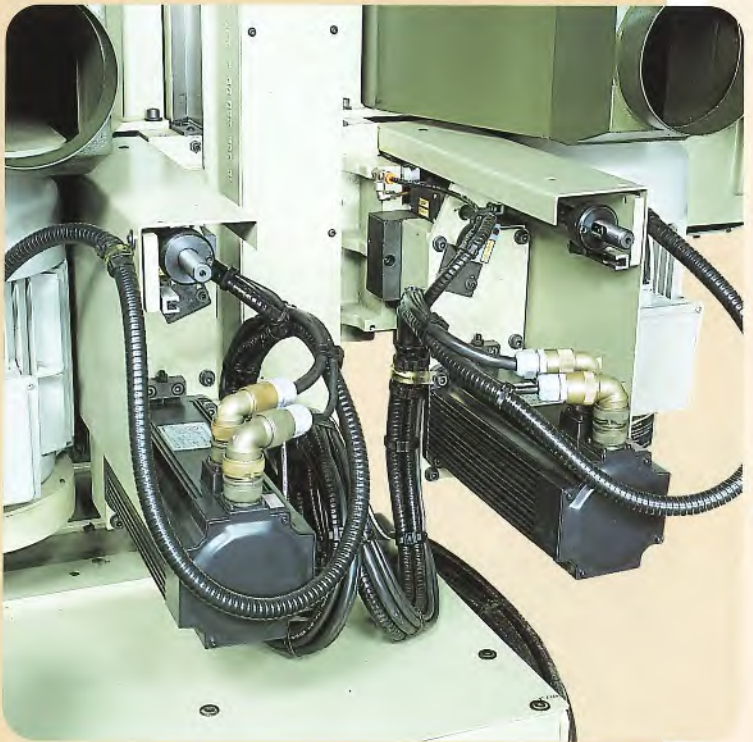

All Copytronic units are driven by brushless motors and have prism guides with automatic forced lubrication as standard.





# CONCEPT 2000

## Examples of configurations

**219**

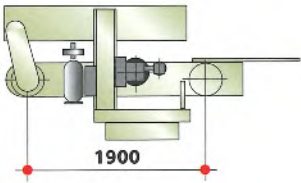

**231**

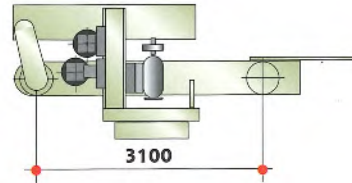

**325**

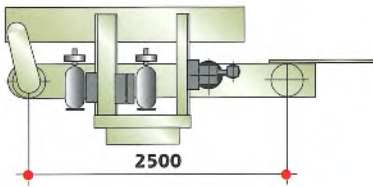

**437 D**

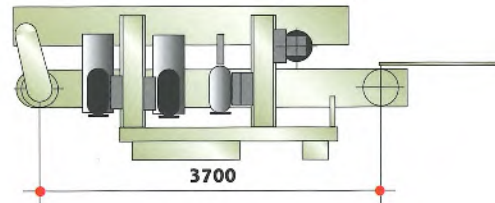

**445 D**

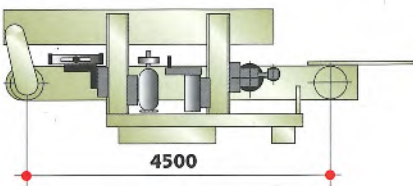

**537 D**

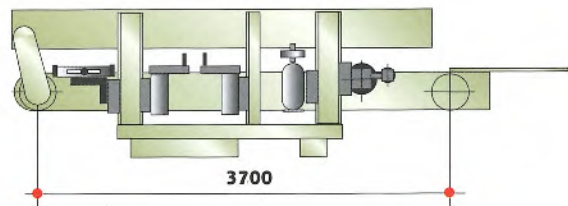

**645 D**

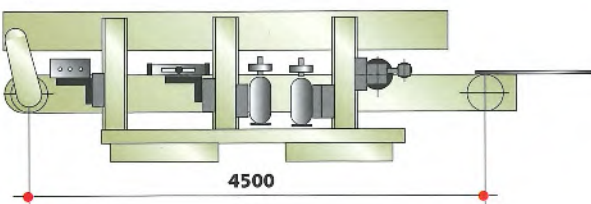

**755 D**

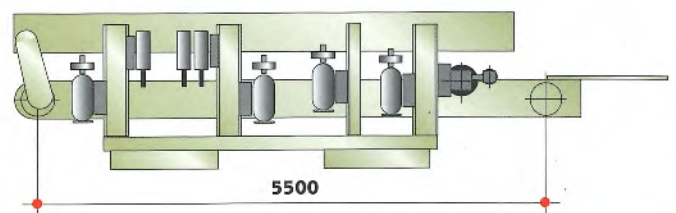





**Safety,  
what you should expect.**

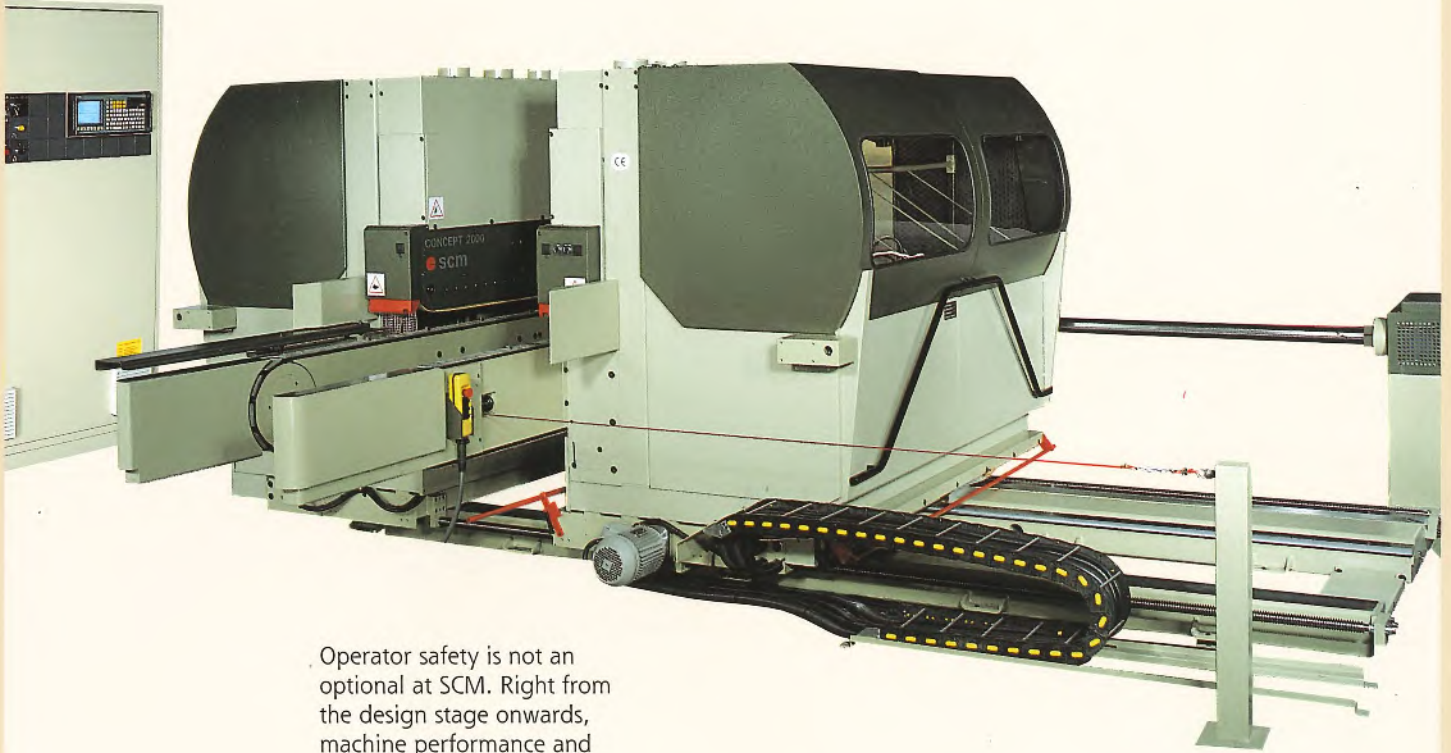

Operator safety is not an optional at SCM. Right from the design stage onwards, machine performance and functions are thoroughly examined to eliminate any risks which might endanger operator health and safety.



**NOISE-DUST**

Model	Noise level according to ISO/DIS 7960 standard				Dust level according to DIN 33893	
	Operator position LAeq [dB (A)]				[mg/m <sup>3</sup> ]	
	Workpiece infeed		Workpiece outfeed		1 <sup>st</sup> station	2 <sup>nd</sup> station
	idle machine		working machine			
<b>CONCEPT 2000</b>	84,2	89	76	80	0,55	0,35



# The leader in integrated lines and systems

Concept 2000 has been designed for use with conventional lines and integrated CNC systems for machining the solid wood components of doors, windows and frames and for processing panels in chipboard, laminate and MDF.

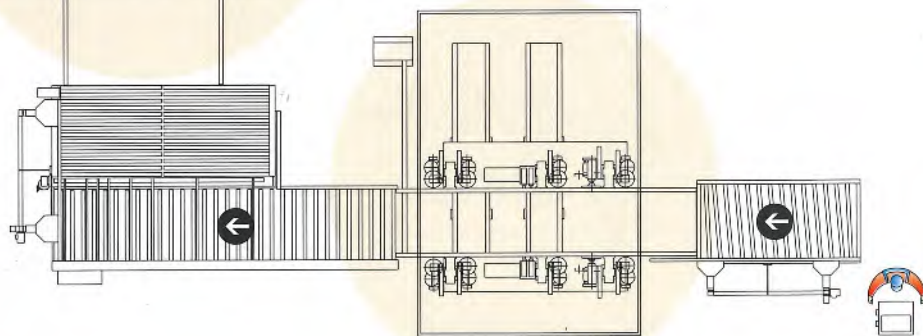
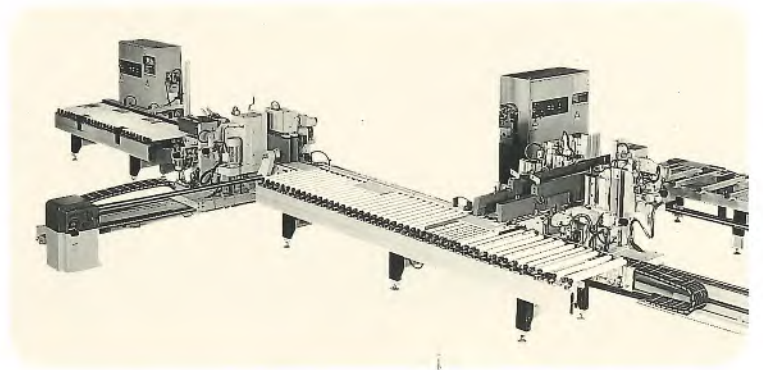
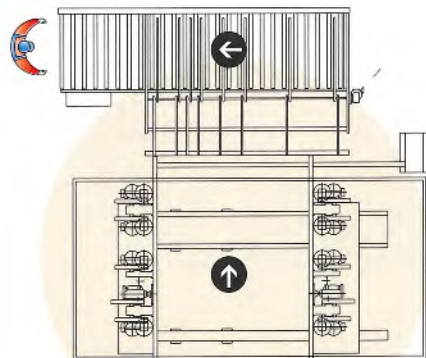
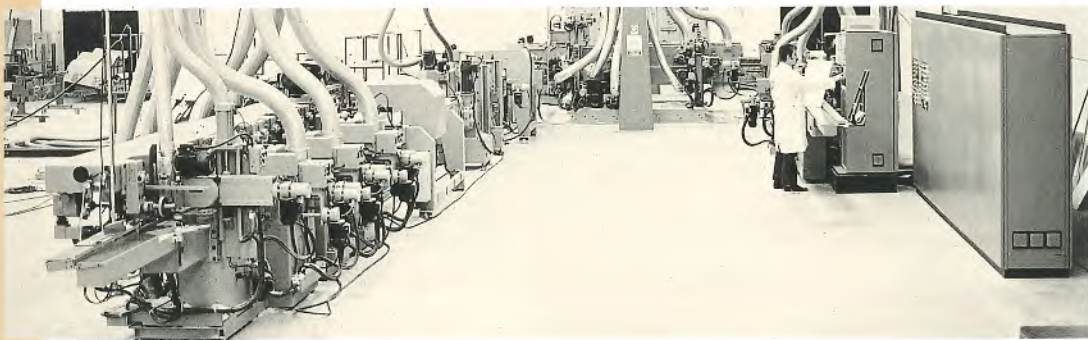
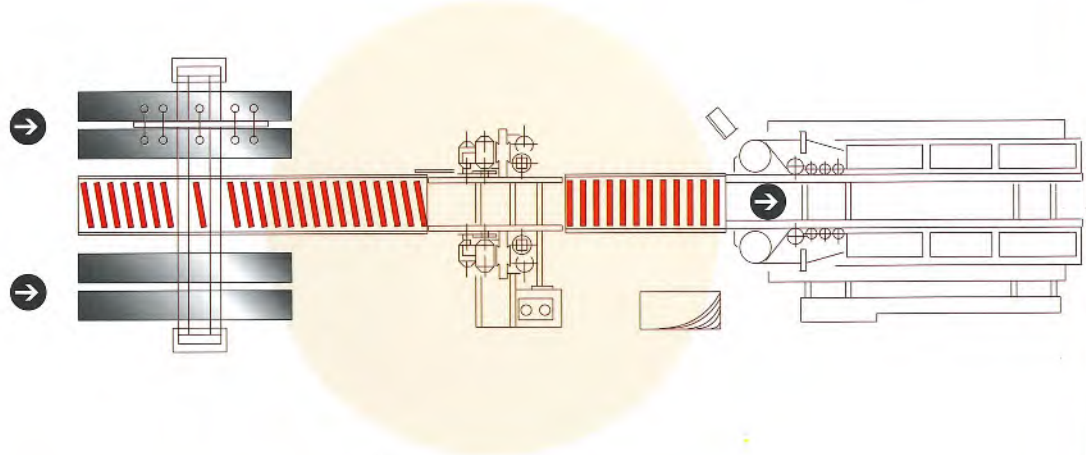



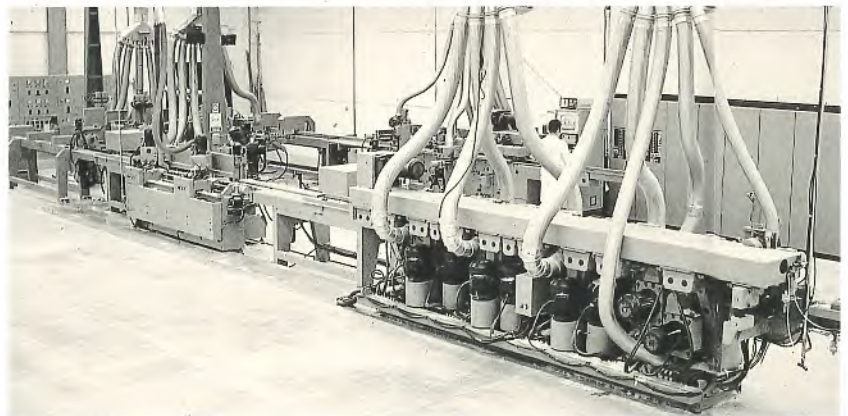
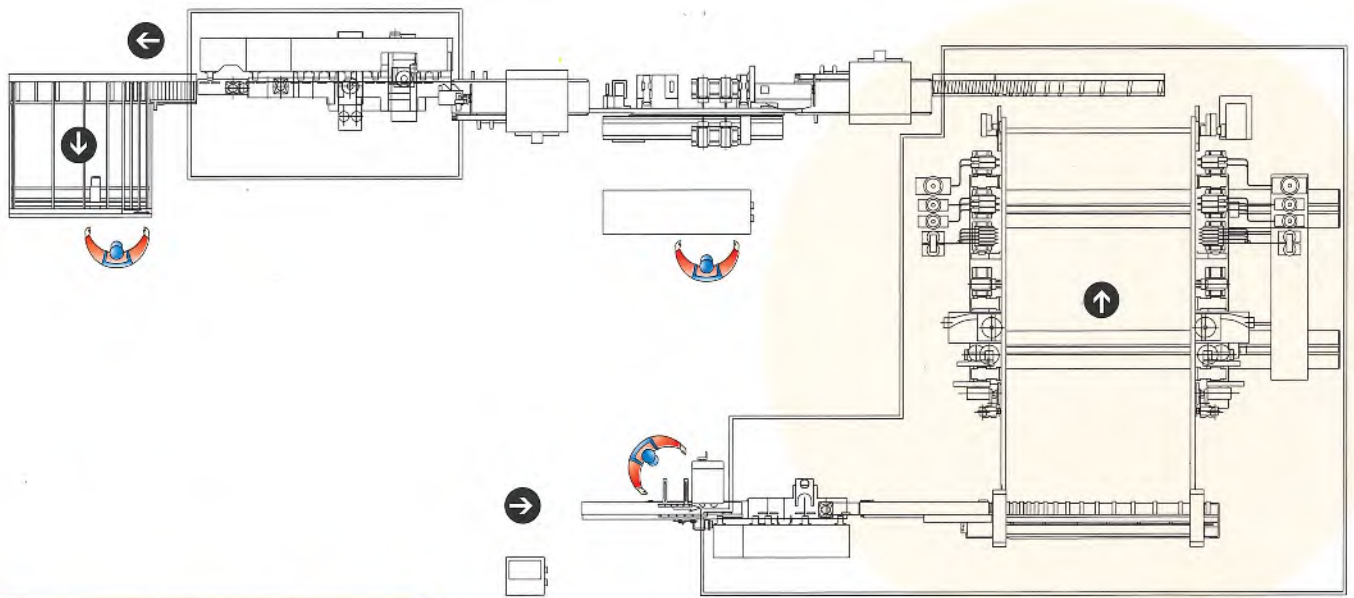
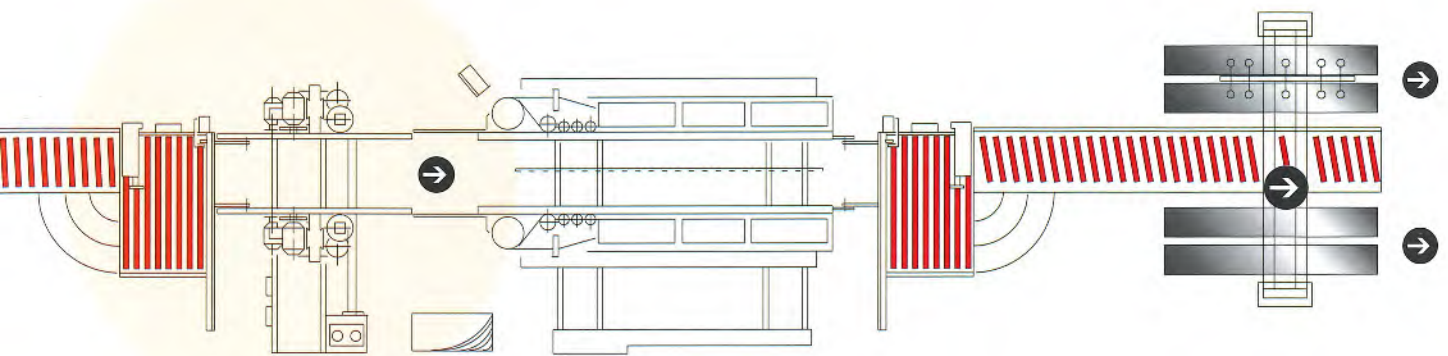



## Technical data

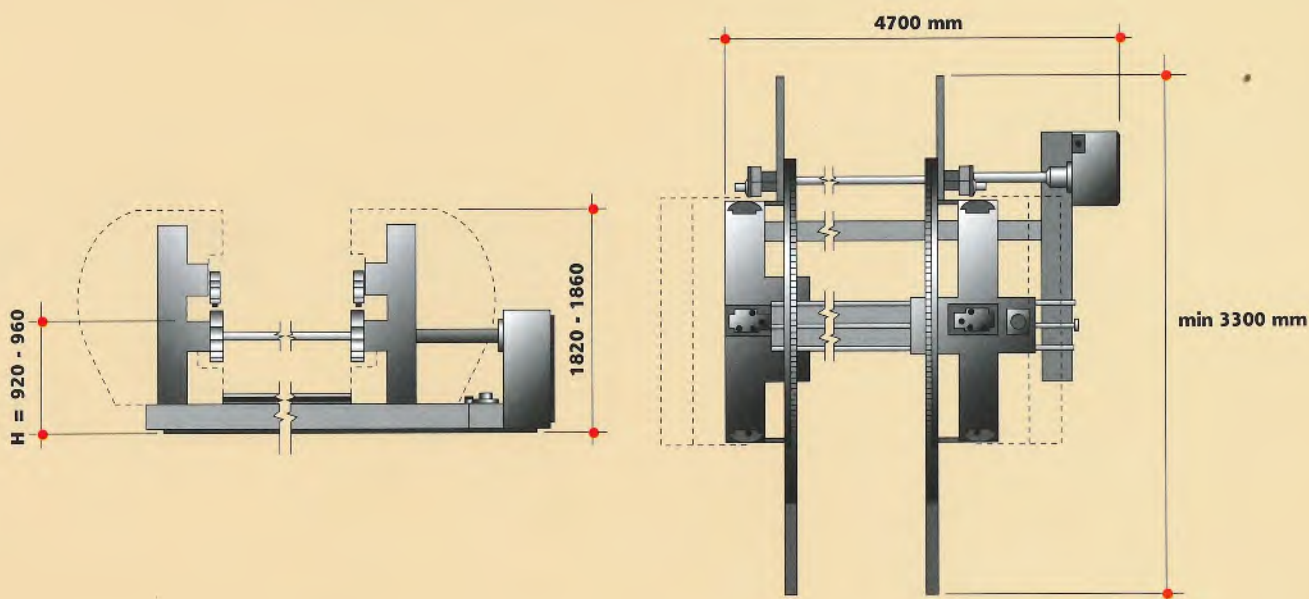

### CONCEPT 2000/20000

Max. working width	mm	3100
Min. working width on single feed belt	mm	75
Min. working width on two feed belts		150
Max. working height	mm	180
Clearance between feed belt and column	mm	200
Feed speed (adjustable)	m/min	3-18
optional (Concept 2000 only).	m/min	8/40
<b>Machining units available:</b>		
Scorer-hogger, 1.1/1.8 kW (1.5/2.5 HP) at 50/100 Hz	rpm	3000/6000
Direct-drive unit, 4.1/6.6 kW (5.5/9 HP) at 50/100 Hz	rpm	3000/6000
Automatic unit, 3.3/5.5 kW at 50/100 Hz	rpm	3000/6000
Automatic relisher on direct-drive unit	rpm	7000
Single-speed, belt-driven spindle moulder		
5.5 kW (7.5 HP)	rpm	3500/7000
7.5 kW (10 HP)	rpm	3500/7000
11 kW (15 HP)	rpm	3500/7000
Two-speed, belt-driven spindle moulder		
4.1/4.8 kW (5.5/6.5 HP)	rpm	3500/7000
5.5/6.6 kW (7.5/9 HP)	rpm	3500/7000
7.5/9.2 kW (10/12.5 HP)	rpm	3500/7000
Multi-stack units		
7.5 kW (10 HP)	rpm	3500/6000
11 kW (15 HP)	rpm	3500/6000
Direct-drive spindle (diameter x length)	mm	40x85
Automatic unit spindle (diameter x length)	mm	40x135
Automatic relisher spindle (diameter x length)	mm	30x85
Belt-driven spindle (diameter x length)	mm	40x150
Multi-stack spindle diameter	mm	50
Multi-stack unit working length	mm	320/620 mm
Scorer blade	diam. mm	55
Hogger blade	diam. mm	80

\* other sizes available on request

\*\* check compatibility with machine configuration





**SCM** has been an active force in the woodworking machinery sector for more than 40 years and represents the nucleus of SCM Group. With a total of 2000 employees, 12 factories and an export of 70%, this group is one of the world's top producers of woodworking equipment.

**SCM** produces the widest range of tooling machines for secondary wood machining, from classical machines to CNC work centres, to high production automated systems for the machining of solid wood. All SCM machines are designed with the aid of CAD (computer aided design) systems and manufactured using the most modern machining and control technology. Specialized technicians all over the world are able to supply the most comprehensive technical assistance and services for SCM customers because full use is made of a system of remote computerised diagnostics and of a

network of peripheral spare parts warehouses. SCM's customers can moreover rely upon the Customer Satisfaction Service recently installed as a reference point covering all their requirements.



**SCM** can also utilize the internal structures of SCM Group such as **CSR-Study and Research Consortium** and CSR Training Centre. CSR-Study and Research Consortium uses advanced experimental and an acoustic instrumentation laboratory fitted with a semianechoic room.

This ensures that all machines satisfy the strictest international standards in terms of safety, ergonomics and environmental hygiene. **CSR-Training Centre**, a highly regarded training school prepares qualified operators for woodworking machinery from all over the world.





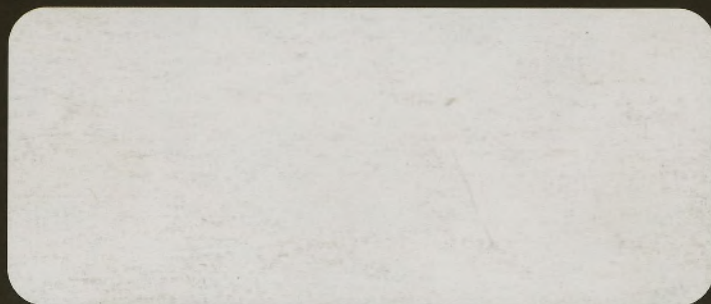

SCM spa  
Via Emilia, 77  
47037 Rimini (FO) - Italia  
Tel. 0541/700111  
Fax 0541/742406