

morbidelli m600/m800

numerical controlled machining centres



morbidelli m600/800

numerical controlled **machining centres**

THE SOLUTION THAT COMBINES QUALITY AND TECHNOLOGY

Modular machining centres designed and developed to satisfy the requirements of furniture manufacturers.





morbidelli m600/800

exclusive features



MACHINING EFFICIENCY: MACHINING HEADS THAT SLIDE ON TWO INDEPENDENT "Z" AXIS

Maximum rapidity during machining changeover with minimized idle times thanks to the double independent "Z" axis on which the two machining heads slide. The possibility to customise the two heads considerably increases the tools available to the operator.

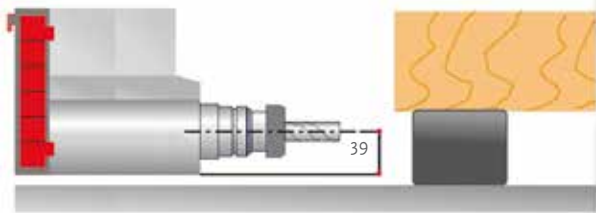

SUPERIOR TECHNOLOGY FOR MACHINING WITH 5 AXES: PRISMA ELECTROSPINDLE

Reduced maintenance, maximum flexibility and optimal finishing quality with the BEL.TECH technology (Belt technology system), the belt transmission system which eliminates vibration and heat from tools to the motor. This system (in use on the spindle for machining metals) due to the compact structure, allows easy operations in limited spaces.



THE PERFECT DRILLING: RO.AX SPINDLE

Zero play during machining with the new RO.AX technology (Rotoaxial spindle technology), the most efficient spindle on the market with rotation speeds up to 8000 rpm. The sturdiness of drilling heads is proven by the reduced maintenance costs: five times less than that imposed by the majority of other machine manufacturers.

THE PERFECT COMBINATION OF SAFETY AND PRODUCTIVITY: PHOTO-BUMPERS

High production capacity and greater freedom of movement also during alternated work process due to the safety system that brings together the bumpers devices with the photocells for the detection of the operator's position inside the loading/unloading area.

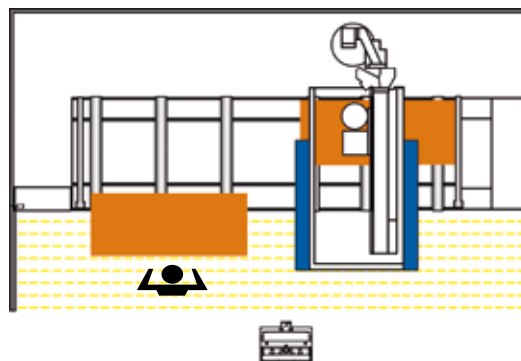

TOTAL LACK OF VIBRATIONS: MOBILE GANTRY STRUCTURE

Performance without comparison with the mobile gantry structure that allows for high machining speeds whilst guaranteeing the best end products quality.



UNIQUE CREATIVITY: XILOG MAESTRO

CAD/CAM programming software to design all the production processes.

Developed in Windows® environment it ensures easy programming with an advanced, simple and intuitive sketching environment that features all the tools necessary to design the parts, their layout on the work table, tools management and the relative machining operations. All the procedures are contained in a perfectly integrated and high performance software.



morbidelli m600/800

machining unit: **routing unit**

Vertical, horizontal, tilting machining and large dimensioned cuts with blade with 3-4-5 axes routing units up to 17 kW motor power.

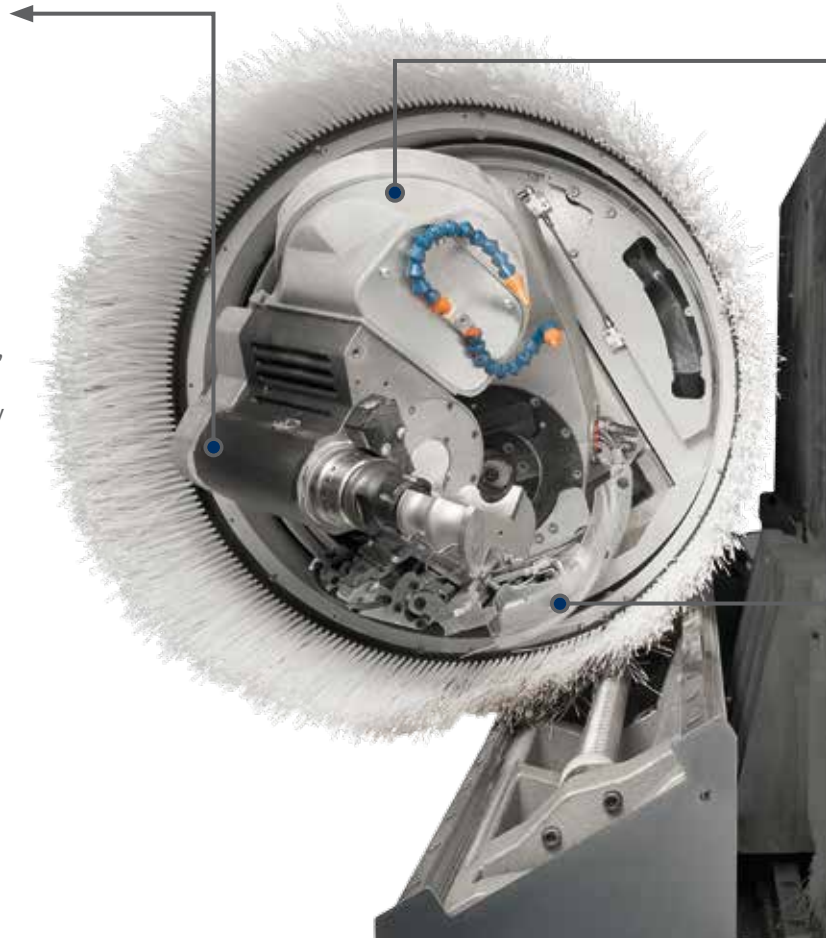

POWERFUL AND RELIABLE

Ease-of-use and flexibility with the 5-axes machining unit, unique in its category in terms of performance. Wide range of specific electrospindles to carry out any type of machining.

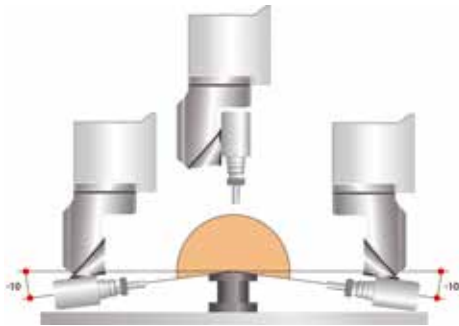

Prisma machining unit geometry allows it to operate at angles of up to 10° below the work piece supporting surface.



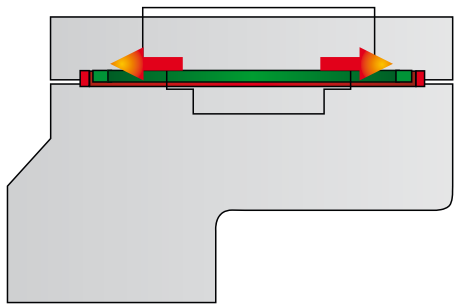
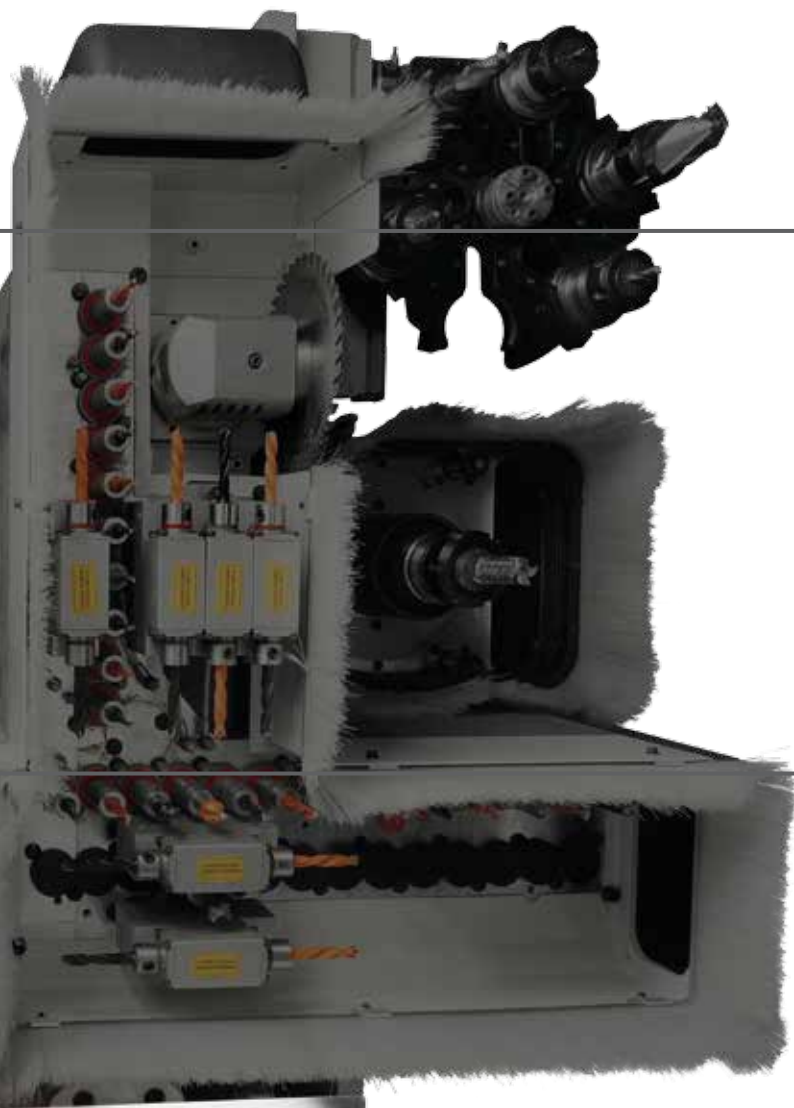

High quality finish even on heavy machining with the exclusive **TTS (Total Torque System) lock system**, that provides the spindle with the stiffness of a 3-axes unit.



Clean working environment with the conveyor facilitating removal of shavings and sawdust produced by machining.



morbidelli m600/800

machining unit: **drilling unit**

The higher drilling capacity in its category with 38 independent vertical spindles and 12 horizontal spindles, complete with blade unit and additional routing unit.

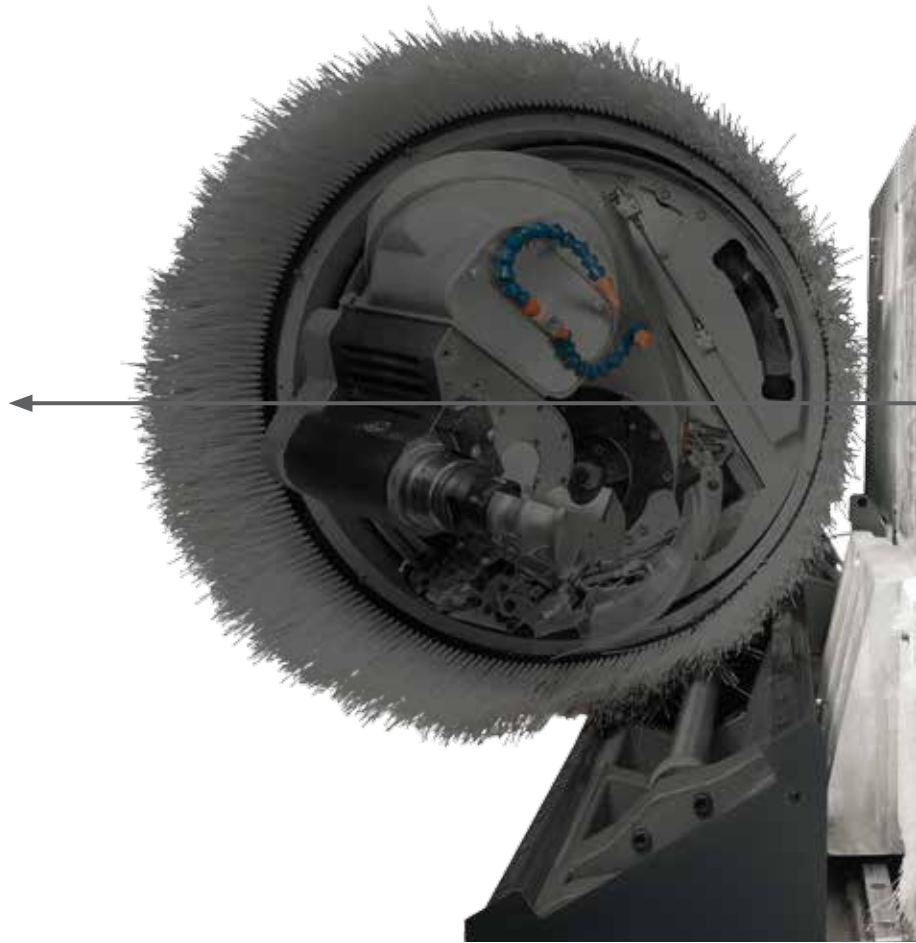
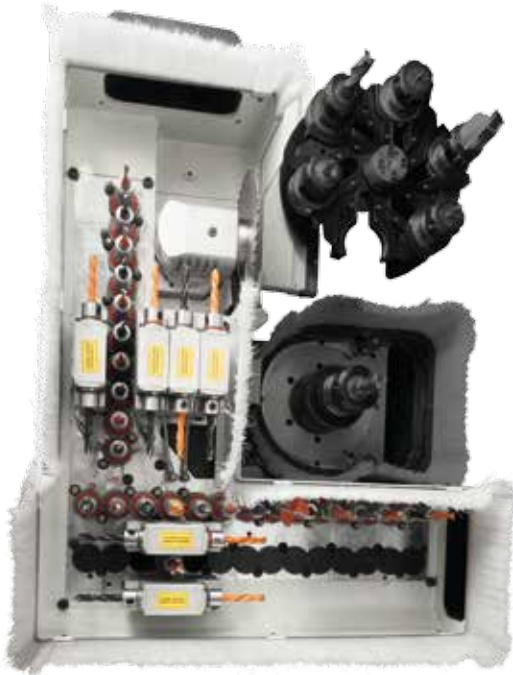

INDESTRUCTIBLE AND WITH LOW MAINTENANCE

The sturdiness of drilling heads is proven by the reduced maintenance costs: it is recommended only after more than 1000 hours of work.



THE PERFECT DRILLING: RO.AX SPINDLE

Zero play during machining with the new RO.AX technology (Rotoaxial spindle technology), the most efficient spindle on the market with rotation speeds up to 8000 rpm.



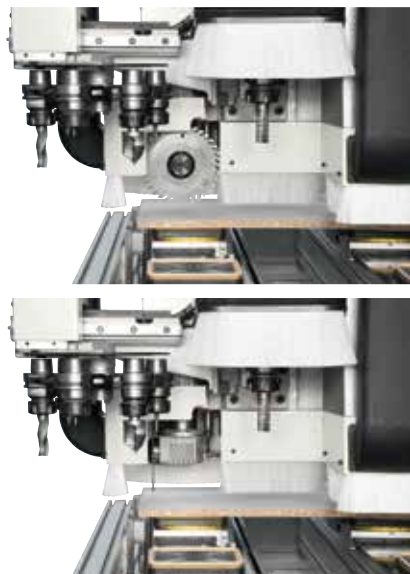
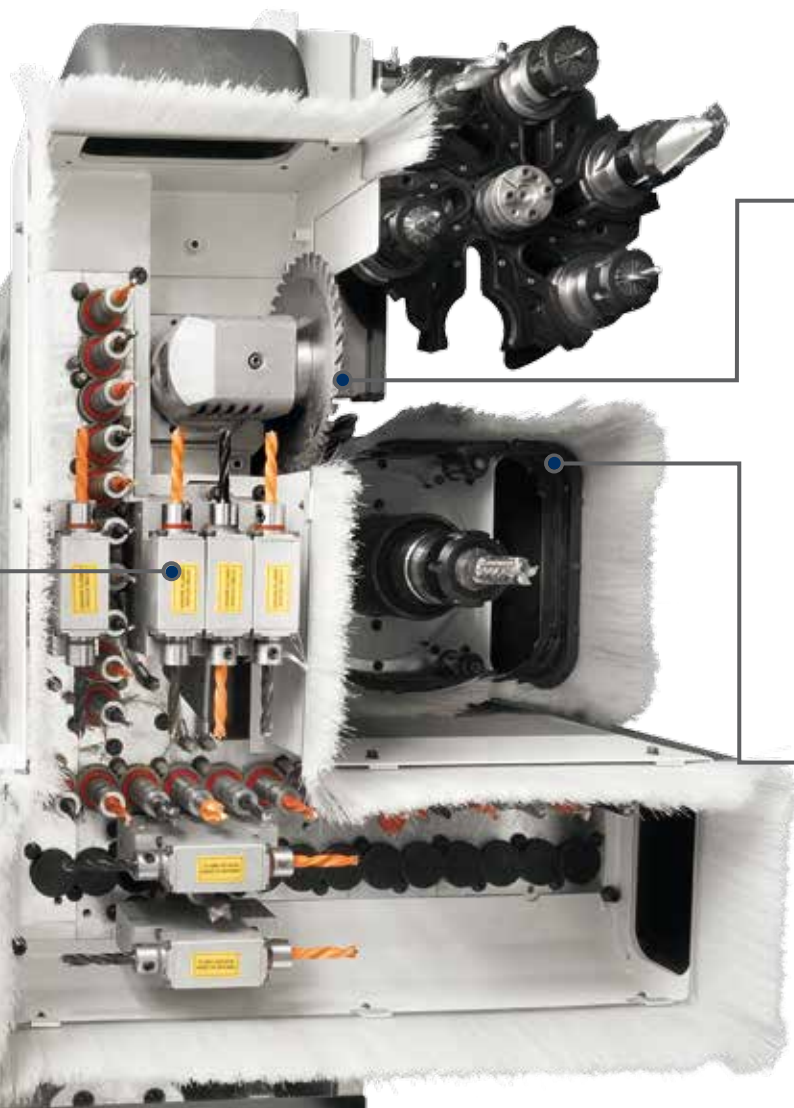

Easy grooves machining on the sides of the furniture thanks to the integrated blade unit with 0-90° rotation.



Higher efficiency and working time reduction with the additional routing unit (PBTC) with 12 kW electrospindle and Rapid 6-position tool changer to carry out the tool change in masked time.



morbidelli m600/800

tool changers

Wide range of tools available to the operator with the rear **RAPID** 16 or 24 positions tool changer.



No idle time for the tool change from a machining process to another one with the **RAPID 12** "on board" fitted directly on the machining unit.

TR side tool changer with 10 or 12 positions.



morbidelli m600/800

machine management



Mobile control panel with PC-Office

Personal Computer with 17" LDC colour display that allows the programming directly on the machine.



"ALL" AT YOUR FINGERTIPS: TECPAD CONTROL

Management of machine controls with the 7" colour remote control with touch-screen function that facilitates and speed up the setting operations.

morbidelli m600/800

bars work table



SET UP TIMES IN MASKED TIME: TV MATIC WORK TABLE

Work table with automatic simultaneous positioning of bars and suction cups or clamps. The requested configuration is performed in just a few seconds with a guaranteed safety against the risks of collision between tool and work table.



Simple and quick substitution of suction cups or clamps through the exclusive rapid docking device.

From a single panel can be obtained more elements and automatically re-position them to carry out all machining without interrupting the production cycle; at the end the work pieces are returned to the initial position to facilitate the unloading from the work table.



Easy positioning of heavy work pieces and large panels with the lifting support.



TOTAL CUSTOMISATION: TV FLEXMATIC WORK TABLE

This automatic table allows the management of a variable number of suction cups on the bar, according to the dimensions and shape of the work piece to be machined, in order to always have the best holding without risks of collision. Available also with manual version (TV FLEX).

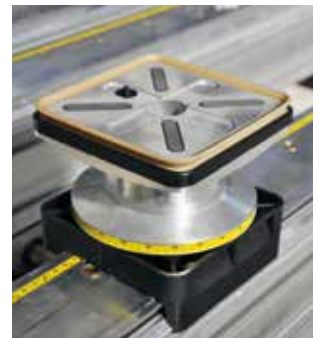

It is possible to position directly on each bar all necessary suction cups and clamps to lock the work pieces of any shape and dimension.

Wide range of accessories, with variable height from 50 to 110 mm, to satisfy all machining necessities and available for all work tables.



morbidelli m600/800

multi-function work table

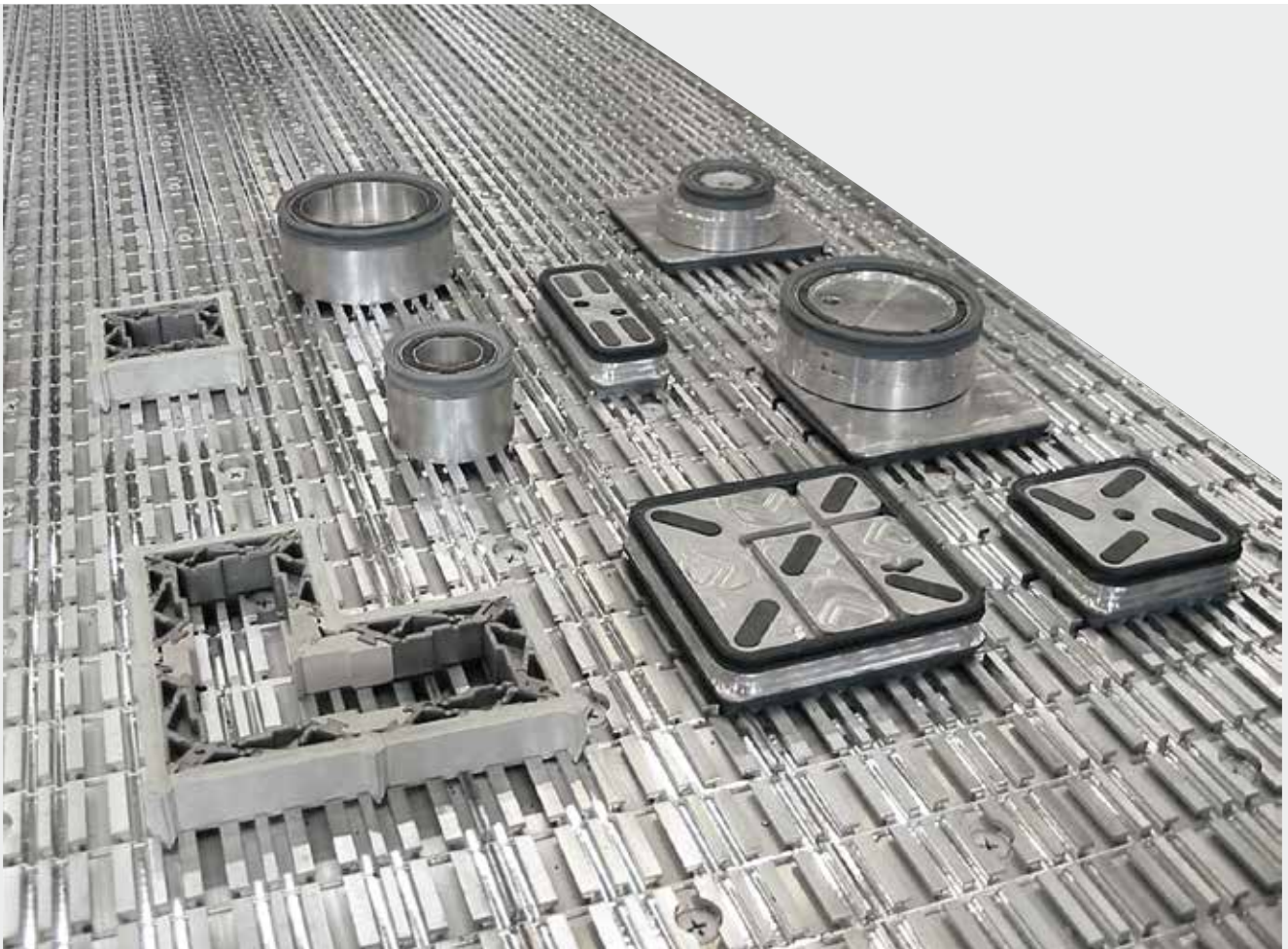

VERY HIGH FLEXIBILITY: MULTI-FUNCTION WORK TABLE

Extremely stiff work table made of extruded aluminium, designed to maintain a perfect planarity over time, even after repeated mechanical stresses. It is ideal also for nesting machining.



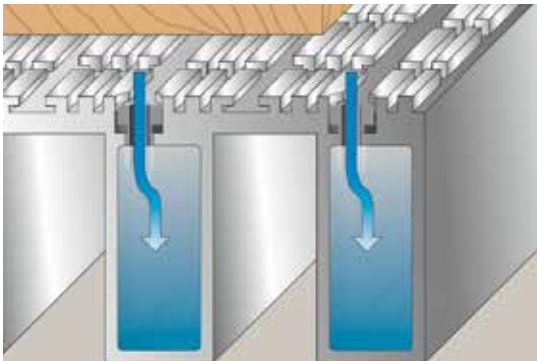

Optimal work piece holding with the high capacity vacuum up to 1000 m³/h.

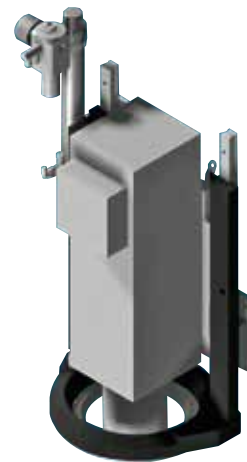

Possibility to work small work pieces with the coaxial mechanical presser.



It is possible to fix custom references thanks to the exclusive "T-shaped" grooves available on the work table. Easy and quick positioning of locking accessories such as MPS suction cups and the practical MODULSET system with the surface channels structure.

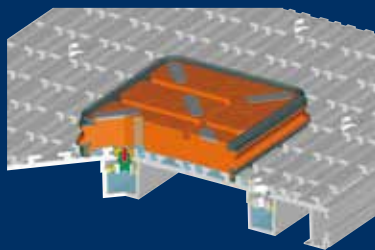

morbidelli m600/800

loading/unloading automation



Precise and rapid panels positioning on the work table with a dedicated suction cups system.

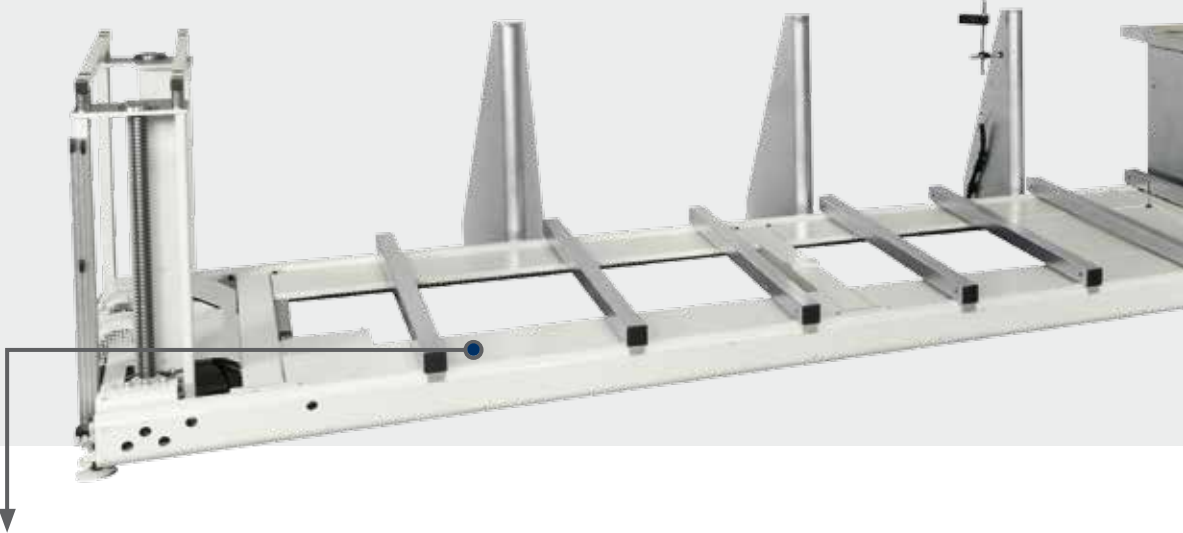

Lifting table for the management of panels stacks with height up to 700 mm.

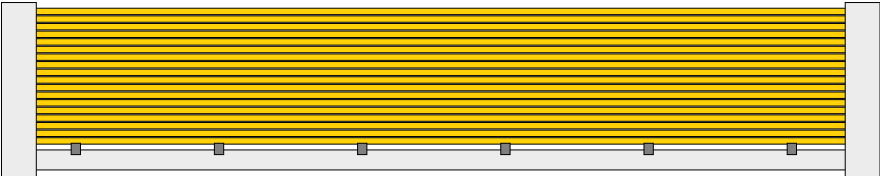



100% productivity with the pusher that moves the processed work pieces on the unloading belt and simultaneously cleans the work table while the new panel to be machined is loaded.

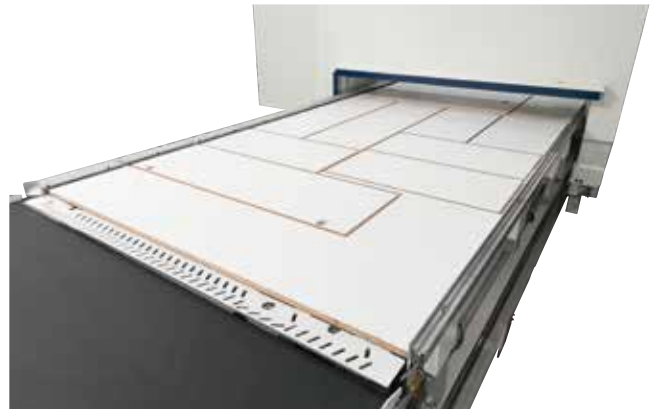

Perfect work pieces holding at outfeed thanks to the guides positioned on the sides that drive the panels avoiding any possibility of falling off. The chips conveying device positioned between the work table and the unloading belt maintain a clean environment.



No dust with the upper extraction system with the work pieces cleaning and chips conveying system at the end of the belt in order to eliminate any machining waste.



morbidelli m600/800

loading/unloading automation

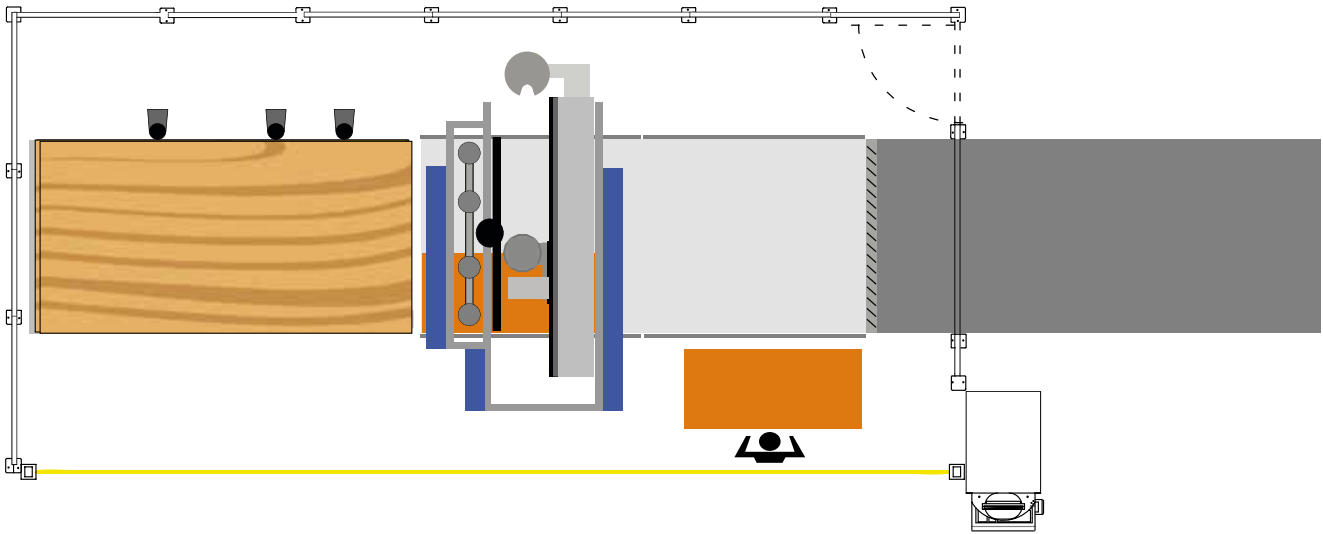

Total flexibility, the cell can be also used with a “stand-alone” machining centre. The photo-bumpers safety system and the split guides allow the manual panels loading/unloading and the pendulum process to maximize the productivity.

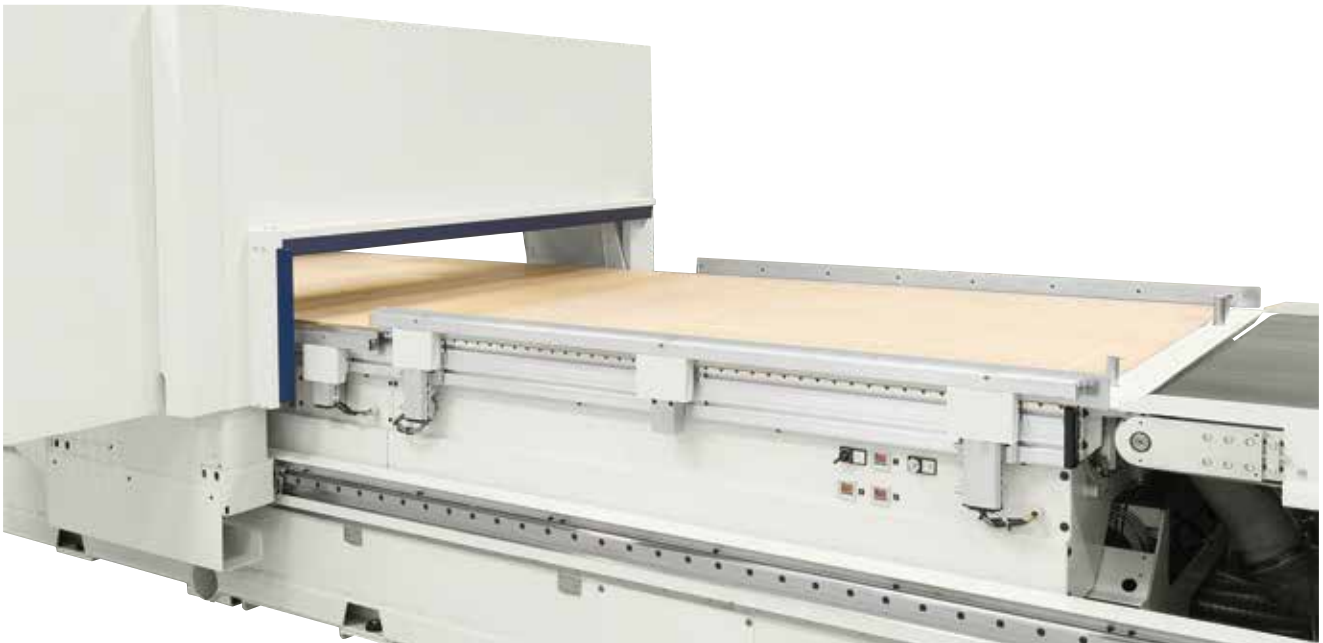

For a higher productivity, in case the material and the machining allows it, the suction cup loading device can position two overlapping panels on the work table.

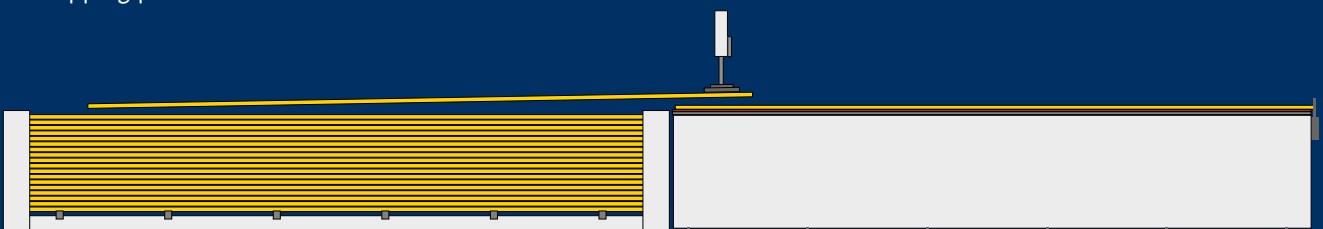

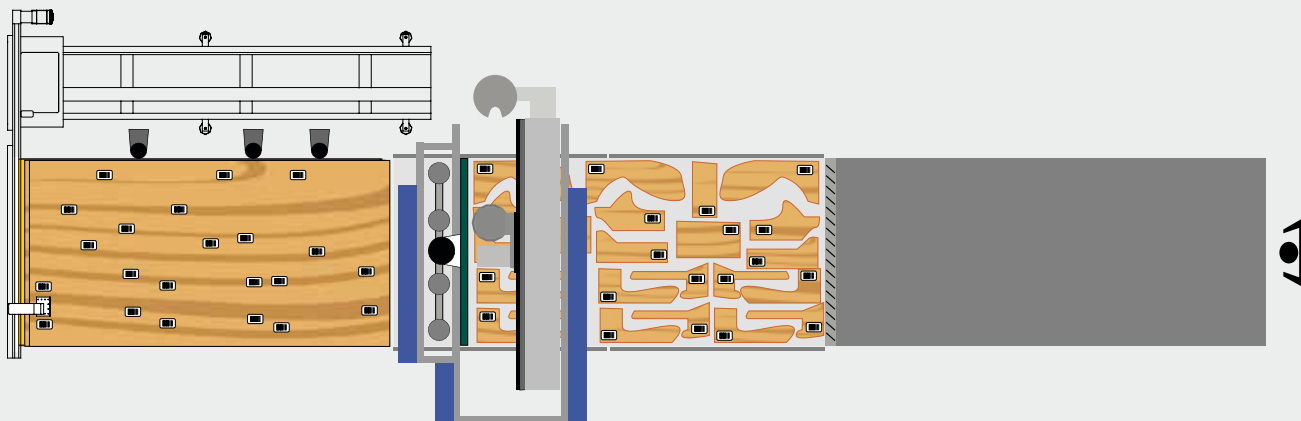

Work pieces labelling

Complete work cycle with the possibility to automatically apply the labels, in masked time, on the infeed panel before the machining.

It is also available the station for the manual labels positioning on the machined panel at the end of the unloading belt.

MORBIDELLI M600		OVERALL DIMENSIONS			
		A	B	C	D
MORBIDELLI M600F LOADING/UNLOADING AUTOMATION					
Working area 3650 x 1600	mm	2900	6000 ÷ 6230	10480	13180
Working area 3650 x 2120	mm	2900	6500 ÷ 6710	10480	13180
Working area 4970 x 2120	mm	2900	6500 ÷ 6710	12300	15240
MORBIDELLI M600F UNLOADING AUTOMATION					
Working area 3650 x 1600	mm	2900	6000 ÷ 6230	7640	10500
Working area 3650 x 2120	mm	2900	6500 ÷ 6710	7640	10500
Working area 4970 x 2120	mm	2900	6500 ÷ 6710	9000	11840

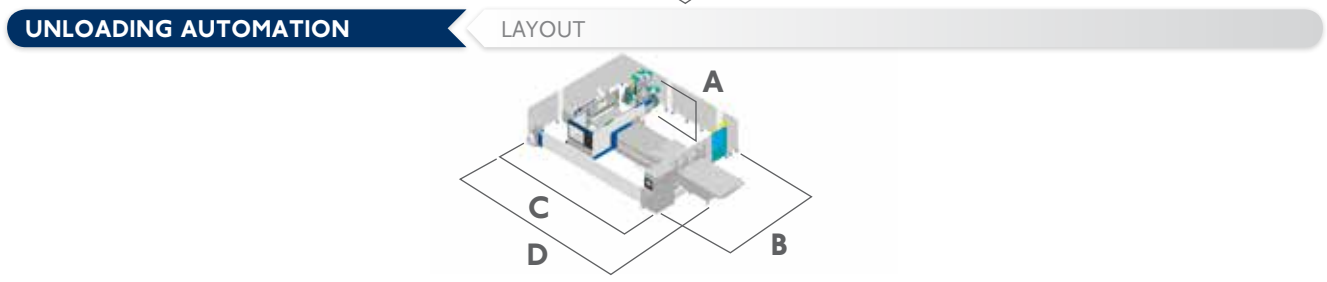
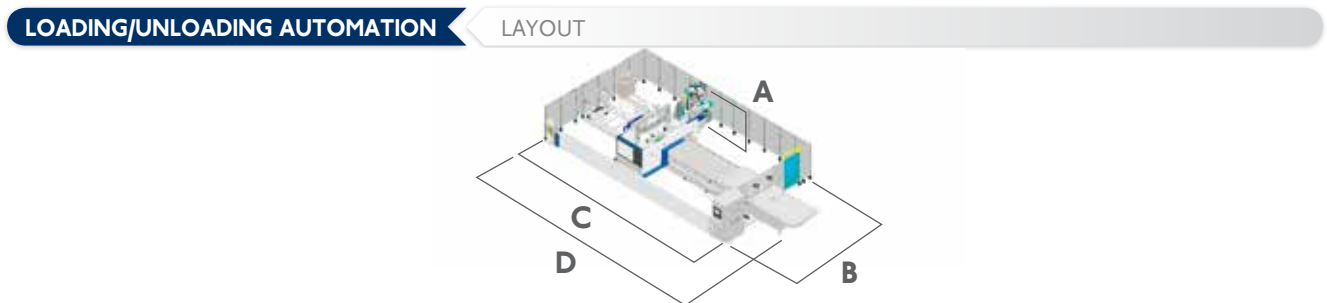

morbidelli m600/800

other devices

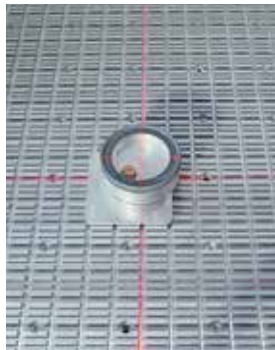
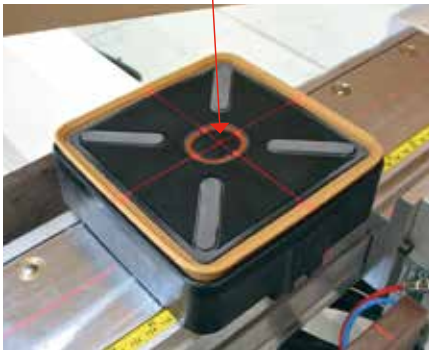

The precision of the suction cups positioning is ensured by the laser device which allows the visualisation of the precise locking point.

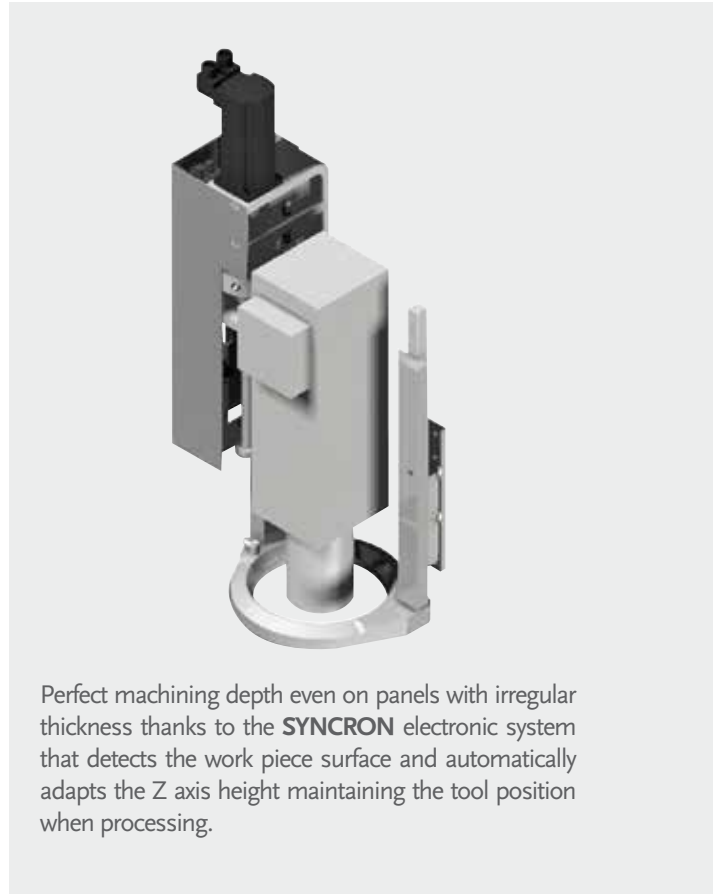

Perfect machining depth even on panels with irregular thickness thanks to the **SYNCRON** electronic system that detects the work piece surface and automatically adapts the Z axis height maintaining the tool position when processing.



Automatic centralised lubrication managed by the control.



Telesolve
Teleservice system to connect the machine's PC to the service department via internet.

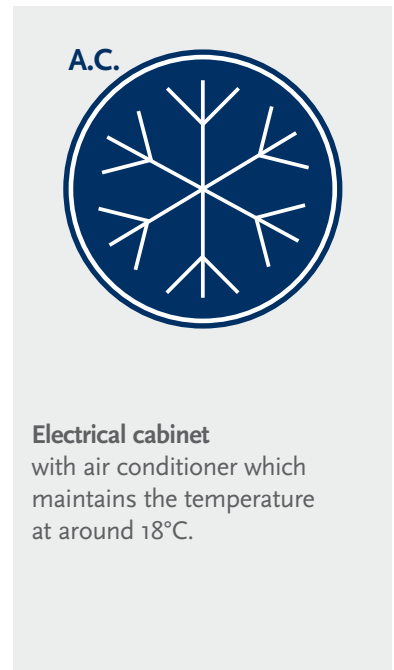

Electrical cabinet
with air conditioner which maintains the temperature at around 18°C.

DEVICES FOR PARTICULAR APPLICATIONS

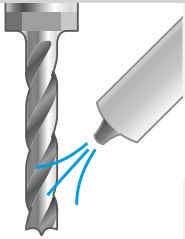

Air blower on electrospindle
For generic applications.

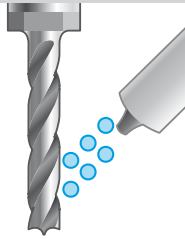

Ionized air blower on electrospindle
It is suitable to eliminate the electrostatic charges due to the cut material, making easier the shavings suction (advisable for plastic materials machining).



Air blower with microlubrication
Air blower with very little oil quantity for the tool lubrication and cooling when used on coated panels.



Guides protections, X-Y axes
By means of dedicated cleaning and protection system, it allows the machining also on abrasive materials (this device is compulsory for machining on plasterboard material).



morbidelli m600/800

software

Maestro

Unique creativity



**CAD/CAM programming software to design
all the production processes.**

Developed in Windows® environment it ensures easy programming with an advanced, simple and intuitive sketching environment that features all the tools necessary to design the parts, their layout on the work table, tools management and the relative machining operations. All the procedures are contained in a perfectly integrated and high performance software.

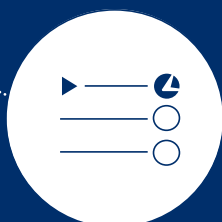

MaestroApps

Unique know-how

Maestro APPS is a library of programming functions that are always available and easy to use, developed by the Scm for the production of parts for doors, windows, stairs, furniture and furnishings.

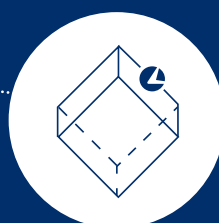

Maestro3D

Unique in the creation of 3D objects

The module integrated in the Xilog Maestro suite is designed to program three dimensional objects on 5-axis machining centres.



MaestroCabinet

Unique in the creation of furniture

This application is designed for the home and office furniture sector to design furniture and program cabinet production step by step.



MaestroNest

Unique nesting process

The module integrated in the Xilog Maestro suite provides all the functions necessary to manage the "nesting" process: from a simple "rectangular" piece to the most varied and complex "free form" geometrical shapes.

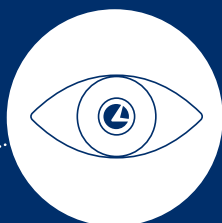

MaestroProView

Unique 3D display

3D Simulator that allows users access to a three dimensional model of their machine in their office and view the operations that will be carried out during the production in advance on their PC.

morbidelli m600/800

safety systems

TOTAL FREEDOM AND HIGH PRODUCTIVITY: PRO-SPEED PROTECTIONS

Protection system for the machine use to the maximum speed of 90 m/min.

When the operator enters into the loading area, which is delimited by the front photocell barrier, the machine automatically reduces the speed to 25 m/min; when the operator leaves the loading area the system restore the maximum working speed.

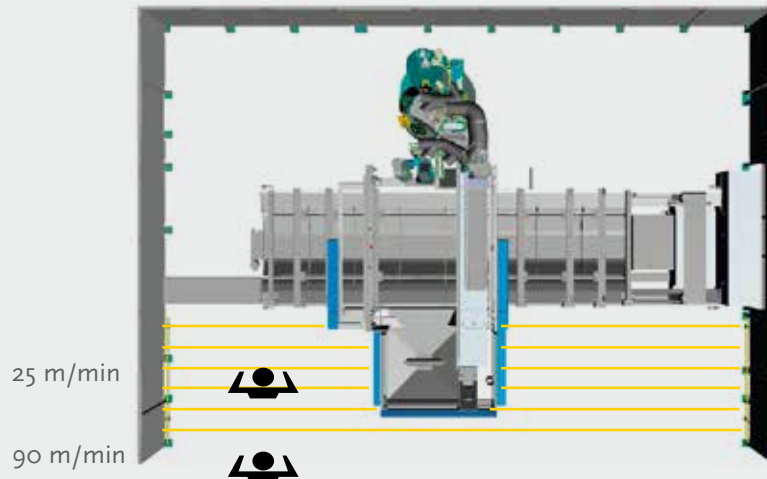

MINIMUM OVERALL DIMENSIONS AND MAXIMUM SAFETY: PRO-SPACE PROTECTIONS

Loading zone completely free to reduce the space occupied to the minimum.

The protections allow the machine to be used with a feed speed up to 25 m/min.



GUARANTEED SAFETY: BUMPERS PROTECTIONS

Fully safe machining with the bumpers safety system with lock the machine in case of accidental contact with the operator.

MORBIDELLI M600 / M800

OVERALL DIMENSIONS

		A	B		C
			PRO-SPEED	PRO-SPACE	
MORBIDELLI M600 / M800 BARS WORK TABLE					
Working area 3680 x 1680	mm	2900	5330 ÷ 6310	4730 ÷ 5600	7560
Working area 3680 x 1905	mm	2900	5440 ÷ 6355	4730 ÷ 5600	7560
Working area 5020 x 1680	mm	2900	5330 ÷ 6310	4730 ÷ 5600	8900
Working area 5020 x 1905	mm	2900	5440 ÷ 6355	4730 ÷ 5600	8900
Working area 6360 x 1680	mm	2900	5330 ÷ 6310	4730 ÷ 5600	10260
Working area 6360 x 1905	mm	2900	5440 ÷ 6355	4730 ÷ 5600	10260
MORBIDELLI M600F / M800F MULTI-FUNCTION WORK TABLE					
Working area 3650 x 1600	mm	2900	5330 ÷ 6310	4730 ÷ 5600	7560
Working area 3650 x 1840	mm	2900	5440 ÷ 6355	4730 ÷ 5600	7560
Working area 3650 x 2120	mm	2900	5730 ÷ 6500	5030 ÷ 5780	7560
Working area 4970 x 1600	mm	2900	5330 ÷ 6310	4730 ÷ 5600	8900
Working area 4970 x 1840	mm	2900	5440 ÷ 6355	4730 ÷ 5600	8900
Working area 4970 x 2120	mm	2900	5730 ÷ 6500	5030 ÷ 5780	8900
Working area 6170 x 1600	mm	2900	5330 ÷ 6310	4730 ÷ 5600	10260
Working area 6170 x 1840	mm	2900	5440 ÷ 6355	4730 ÷ 5600	10260
Working area 6170 x 2120	mm	2900	5730 ÷ 6500	5030 ÷ 5780	10260

PRO-SPEED

LAYOUT

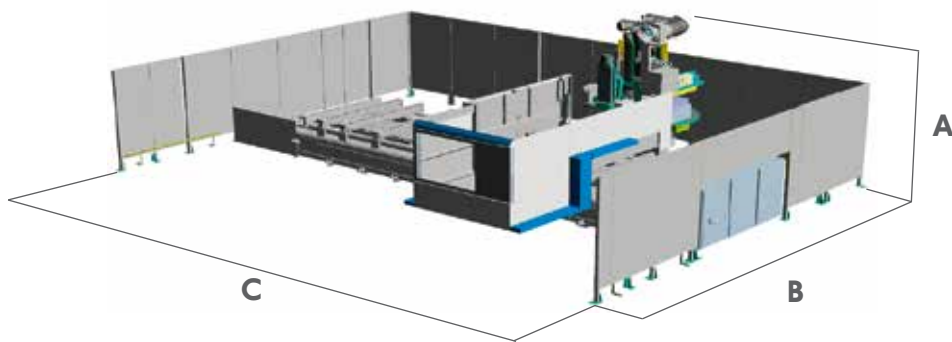

PRO-SPACE

LAYOUT

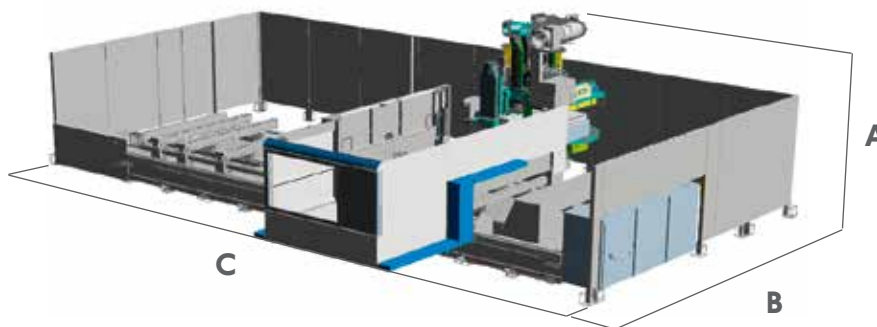

morbidelli m600/800

MORBIDELLI M600 / M800

TECHNICAL DATA

MORBIDELLI		M600	M800
AXES			
Vectorial speed X-Y axes	m/min	127	127
Z axis speed	m/min	30	30
Z axis panel passage	mm	250	350
ROUTING UNIT			
Motor power (max.)	kW (hp)	17 (23)	17 (23)
Rotation speed (max.)	rpm	24000	24000
Available tools on tool changer (max.)	places	54	54
DRILLING UNIT			
Independent vertical spindles (max.)	n.	38	38
Independent horizontal spindles (max.)	n.	12	12
Rotation speed (max.)	rpm	8000	8000
Integrated blade in X, diameter	mm	125	125
0-90° integrated blade, diameter	mm	160	160
INSTALLATION			
Exhaust air consumption	m ³ /h	5140	5140
Exhaust air speed	m/sec	25	25
Exhaust outlet diameter	mm	250+100	250+100



LOWER CONSUMPTION = LOWER COSTS

SavEnergy allows the use of power only when it is required, making things operate only when they are really necessary. It means the machine automatically enters "stand-by" mode when there are no panels to be machined.

Maximum noise levels measured according to the operating conditions established by EN 848-3:2012:

Acoustic pressure in process (routing) 81 dbA (measured according to EN ISO 11202:2010, uncertainty K = 4 dB)

Acoustic power in process (routing) 98 dbA measured according to EN ISO 3746:2010, uncertainty K = 4 dB)

Even if there is a correlation between above mentioned "conventional" noise emission values and average levels of personal exposure over eight hours of operators, these last also depend on the real operating conditions, duration of exposure, acoustic conditions of the working environment and presence of further noise sources, this means the number of machines and other adjacent processes.

THE STRONGEST WOOD TECHNOLOGIES ARE IN OUR DNA

SCM. A HERITAGE OF SKILLS IN A UNIQUE BRAND

Over 65 years of success gives SCM the centre stage in woodworking technology. This heritage results from bringing together the best know-how in machining and systems for wood-based manufacturing. SCM is present all over the world, brought to you by the widest distribution network in the industry.

65 years history

3 main production sites in Italy

300.000 square metres of production space

17.000 machines manufactured per year

90% export

20 foreign branches

350 agents and dealers

500 support technicians

500 registered patents

In SCM's DNA also strength and solidity of a great Group. The SCM Group is a world leader, manufacturing industrial equipment and components for machining the widest range of materials.

SCM GROUP, A HIGHLY SKILLED TEAM EXPERT IN INDUSTRIAL MACHINES AND COMPONENTS

INDUSTRIAL MACHINERY

Stand-alone machines, integrated systems and services dedicated to processing a wide range of materials.



WOODWORKING TECHNOLOGIES



TECHNOLOGIES FOR PROCESSING COMPOSITE MATERIALS, ALUMINIUM, PLASTIC, GLASS, STONE, METAL

INDUSTRIAL COMPONENTS

Technological components for the Group's machines and systems, for those of third-parties and the machinery industry.

HITECO

SPINDLES AND TECHNOLOGICAL COMPONENTS

Ees

ELECTRIC PANELS

steelmec

METALWORK

scmfonderie

CAST IRON



The technical data can vary according to the requested machine composition. In this catalogue, machines are shown with options. The company reserves the right to modify technical specifications without prior notice; the modifications do not influence the safety foreseen by the CE Norms.



is more



SCM GROUP SPA

via Casale 450 - 47826 Villa Verucchio, Rimini - Italy
tel. +39 0541 674111 - fax +39 0541 674274
morbidelli@scmgroup.com
www.scmwood.com



00L0367198D