

# Powerful and economic

Schuko Residual Wood Shredder  
Series ZM 800-K / 900-K / 1000-K



**Schuko**

Dust extraction and filter technology



## \*EFFICIENTLY REDUCING FUEL COSTS THROUGH RESIDUAL WOOD SHREDDING\*

Shredders from Schuko were developed for chopping residual, coarse wood. They are ideal for carpenters and small to medium businesses which accumulate residual wood, solid wood, MDF, chipboard, pallets or anything similar.

Depending on the intended use of the shredded material, different mesh sizes can be supplied.

Thus, the shredded goods can save costs. Alternatively, a direct compression of the loose material, available in briquette form is also possible via a connection to a Compacto briquetting system. These are space-saving to store and can possibly sell for a profit. With a very high volume of shredding, a connection to an extraction system or to a chip bin is recommended. This creates an automatic disposal system that is completely worth it!

### Control system:

- ✓ A space-saving external control cabinet (also appropriate for wall mounting)
- ✓ Schuko's quality components provide maximum operational safety
- ✓ Automatic functional running through a PLC system
- ✓ Easy to adjust the machine's operating time
- ✓ Indication of operating hours
- ✓ Text display in case of machine malfunctions
- ✓ An energy-saving switch is available



**The motor:**

Costs can be saved through two different versions of high efficiency motors belonging to energy efficiency classes IE3. Due to the direct drive, Schuko shredders can achieve around 10% more power at the shaft compared to belt-driven models and therefore work much more efficient. They are very easy to maintain and they do not require further adjustments during operation.

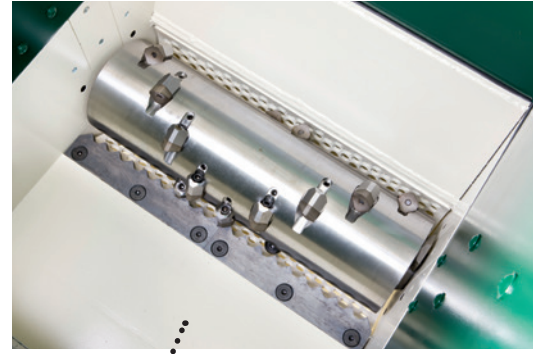
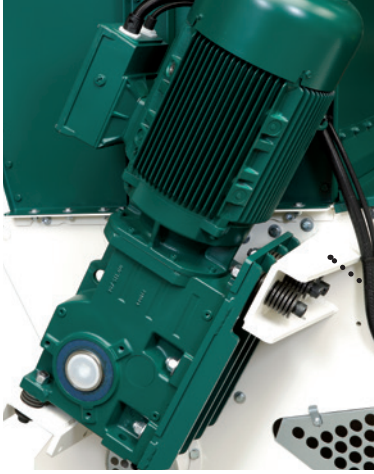

**The Cutter:**

Specific Schuko cutters with clearance and cutting angles help you save approximately 2kW of motor output. Their quadrangular shape with 4 cutting points does not only ensure results with permanently improved cutting results, but also reduces operating costs due to their repeated applicability. Additionally, the cutters and cutter holders are replaceable which means that the parts can be replaced individually. Lateral rakers inserted into the cutter shaft prevents wrapping of the material at the end of the rotor shaft. The counter blades can be turned around and therefore can be used twice.

**The casing:**

The appliance's solid construction and additional reinforcements on the engine intake and torque support enables a long lifetime and a trouble-free operation.

Material performance is supported through a slanted material. Therefore, the shredded material is pressed more effectively.

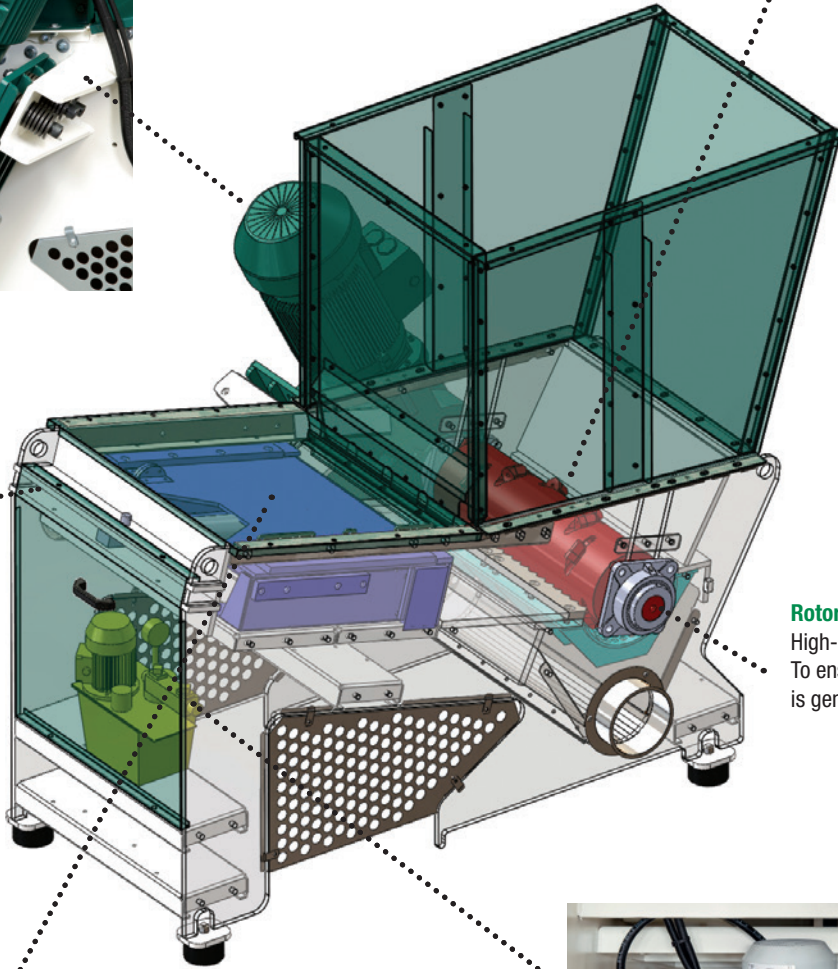

**Rotor storage:**

High-quality flange bearings. To ensure long durability, the rotor storage is generously dimensioned.



**Hydraulic unit:**

The space-saving hydraulic unit is situated within the machine's body and provides a powerful propulsion of the drawer. A visual indicator allows you to see the oil level.

**Slide:**

The special construction enables a low-wear guidance of the slide. The end-position control of the slide is implemented by a maintenance-free limit switch.



## Powerful and economic

### Convincing arguments:

#### ✔ Solid

Extremely durable due to a solid, steel frame construction made of 15-mm of steel with accurate laser cutting.

#### ✔ Resilient

The cutter is made of solid steel which guarantees high-torque cutting operations. The machine layout ensures pressure-optimised material feed to the cutting rotor.

#### ✔ Low-wear

Drive of the rotor shaft via a high-performance gear unit. This reduces belt slippage in order to reduce wear to a minimum.

#### ✔ Flexible

Easy replacement of the sieves with different mesh sizes. This ensures chips sizes according to requirements concerning further processing.

#### ✔ Long-living and failure-free

Drawer guidance of highly wear-resistant polyamide (PA6) guarantees long lifetime.

The driving unit (motor and gearbox) is connected to a torque support via disk springs. Thanks to this design, different pressures or impacts on the rotor shaft are absorbed. This ensures smooth running and durability.

Motor-protecting, failure-free wood off-cut shredding by electronic monitoring of power consumption and consequential alteration to sense of rotation of the rotor shaft.

#### ✔ Easy to maintain

The modular hydraulic drive and easy accessible lubrication points makes maintenance easy.

### The advantages at a glance:

- ✔ Energy saving due the slow running and automatic idle shutdown
- ✔ Always ready for use with reusable cutters
- ✔ Low noise level in operation
- ✔ Powerful with high throughput
- ✔ A solid and durable appliance thanks to precisely fitting and extremely strong construction
- ✔ Modern Logic Control (PLC)
- ✔ User-friendly by well arranged control elements
- ✔ ...

**Dimensions:  
ZM 800-K / ZM 900-K / ZM 1000-K**

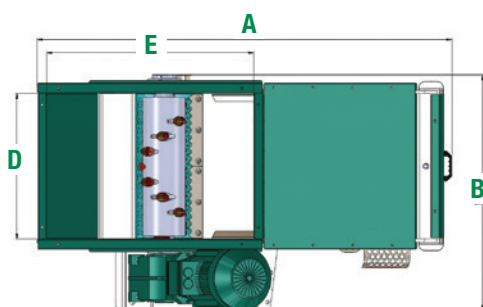
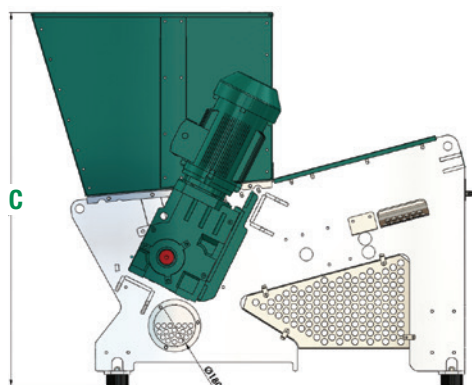
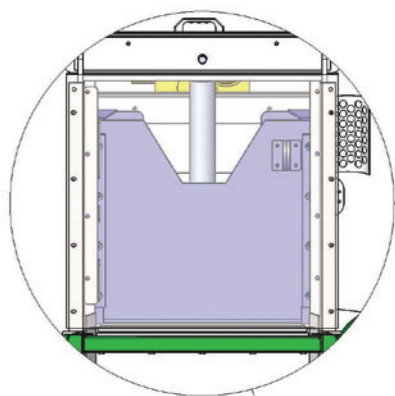
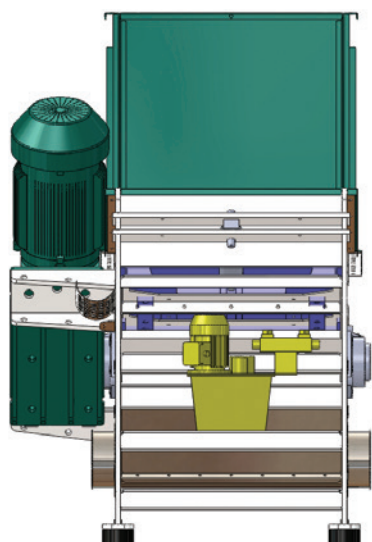

**Technical data**

Type	ZM 800-K	ZM 900-K	ZM 1000-K
Order no.:	975300	975400	975500
Material performance depending on the type of material and mesh size (kg/h)	220 to 300	250 to 350	350 to 650
Funnel opening (mm) <b>D x E</b>	710 x 990	710 x 990	990 x 990
Funnel capacity (m <sup>3</sup> )	0,5	0,5	0,7
Rotor diameter (mm)	220	220	220
Length of rotor (mm)	680	680	960
Rotor speed (U/min)	106	106	106
Motor power (kW)	15	18,5	18,5
Standard mesh aperture* (mm)	18	18	18 - 30
Cutter/pc	19	19	27
Rakers	2	2	2
Hydraulic feed	yes	yes	yes
Extraction port Ø (mm)	180	180	250
Air rate (m/s) required	28	28	28
Machine resistance (Pa.)	450	450	430
Weight (kg)	1.400	1.450	1.700
Length mm	<b>A</b> 2.050	2.050	2.050
Width (mm)	<b>B</b> 1.270	1.220	1.800
Height (mm)	<b>C</b> 1.710	1.710	1.710
Operating time is easily adjustable	yes	yes	yes
Control	SPS	SPS	SPS

\* Depending on application the following mesh sizes can be delivered:  
14, 16, 18, 20, 22, 24, 30 mm

Dimensions of the control cabinet 600 x 600 x 200 mm (w x h x d)  
Set-up area of the control cabinet 840 x 440 mm (w x d)



**Shredded items:**  
From square timber to wooden panel - everything can be shredded without problems thanks to the Schuko ZM shredder series.



## At home in Germany - move in Europe

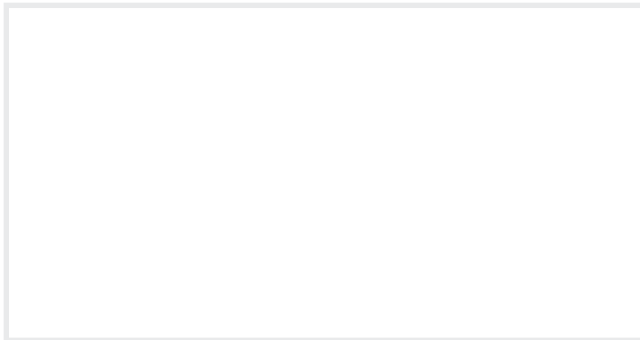

# Schuko

Dust extraction and filter technology

**Schuko International GmbH & Co. KG**  
Heinrich-Schulte-Südhoff Str. 1  
14959 Trebbin, Germany

☎ +49 (0) 33731 / 77 77 94 or 95

☎ +49 (0) 33731 / 77 77 96

[international@schuko.com](mailto:international@schuko.com)

[www.schuko.com](http://www.schuko.com)