



One machine for one or several different window or door types

The Pentho Control is produced with one or more vertical spindles and a noise reduced cut off saw. With the tool splitting technology tools from all the spindles can be combined with each other. The solid table can turn in two directions up to 45° to make angled windows. The Pentho Control can be entirely automated and be combined with a "Profil Control" in order to come to a complete window line.



The table can be swivelled 45° in two directions. The working surface of the table changes not in shape.



Each module is equipped with pneumatic aluminium protection plates.



Tools on the different spindles can be combined to make one profile.

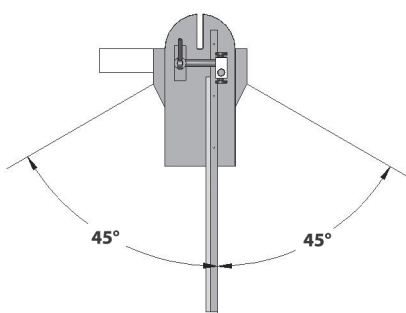

7" touch panel for the full operation of the machine.



PENTHO CONTROL



TECHNICAL DETAILS

FRAME

7" touch panel:	For the operation of the machine Selecting of all motors by the panel
Construction:	Combined self supporting frame with a cage construction
Safety screen:	Pneumatic aluminium protection plates
Security:	Conform CE.

TABLE

Table mounting:	Horizontal on rails, extra solid
Movement:	Manual; automatic movement option
Table:	Swivelling +/- 45°, fixed in height Blowing system on table for cleaning
Backing wood:	Round backing wood with 4 manual positions, clamp for straight backing wood; pneumatic backing wood option
Clamps:	2 vertical pneumatic clamps
Length fence:	2.4 m; 3.4 m automatic length-fence option
Dimensions:	160 mm x 1000 mm (usefull)

CUT OFF SAW

Motor:	2,2 kW - 3000 tpm
Adjustment:	Hor. 150 mm, cut-off capacity up to 200 mm
Tool:	Noise reduced saw included, diam. 450
Extraction:	Ø 80 mm
Positioning:	Manual; digital read-out or CNC option

VERTICAL SPINDLE (S)

Motor	7,5 kW; 11 kW option
RPM:	4000 tpm
Suspension:	Dove tail
Movement:	Vertical 0 - 500 mm
Positioning:	Vertical CNC-positioned with ball circulating screw Horizontal fix; on/off or CNC-positioned option
Spindle length:	300 mm with Prolock or 545 mm with top bearing
Spindle Ø:	Ø 50 mm
Tool Ø:	Max. Ø 350 mm
Extraction:	Ø 180 mm

STANDARD



Digital read-out and one large swiveling back stop

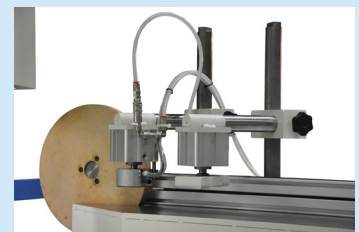

Pneumatic clams

OPTIONS



15" touch panel with separate control console



Automatic length-fence