

**PROGRAMM  
KURZÜBERSICHT**

**GENERAL  
OVERVIEW**

**APERÇU DE NOTRE  
PROGRAMME**

**MASCHINEN FÜR DEN  
FENSTERBAU**

**MACHINES FOR  
WINDOW CONSTRUCTION**

**MACHINES POUR LA  
FABRICATION DE FENÊTRES**

### AKS 1



Auslinksäge AKS 1  
End Notching AKS 1  
Fraiseuse en bout AKS1

### SK 250 TS



Tischkreissäge SK 250 TS  
Circular Table Saw SK 250 TS  
Scie déligneuse SK 250 TS

### DS 120

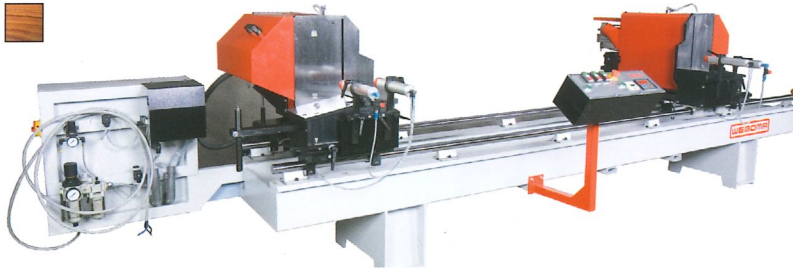

Doppelgehrungssäge DS 120  
Double Mitre Saw DS 120  
Tronçonneuse double DS 120

### MS 550



Tischkreissäge MS 550  
Circular Table saw MS 550  
Tronçonneuse à lame ascendante MS 550

### DS 130



Doppelgehrungssäge DS 130  
Double Mitre Saw DS 130  
Tronçonneuse double DS 130

### TKS 400



Tischkreissäge TKS 400  
Circular Table saw TKS 400  
Tronçonneuse à lame ascendante MS 400

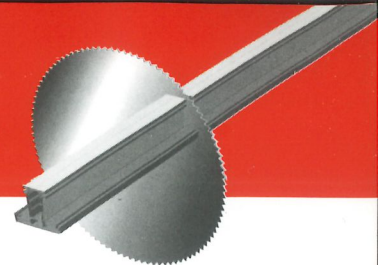

**KF 300**



Kopierfräse Einspindel KF 300  
Copy Router One Spindle KF 300  
Fraiseuse à Copier I axe KF 300

**TS 73 C**



Gehrungssäge TS 73 C  
Mite Saw TS 73 C  
Scie à Onglet TS 73 C

**GL 142 M/P**



Glasleistensägen GL 142 M/P  
Glazing Bead Saw GL 142 M/P  
Scies à Parcloses GL 142 M/P

**BG 10 D**



Metallkreissäge BG 10 D  
Steel Saw BG 10 D  
Scie circulaire à métaux BG 10 D

**Längenanschläge / Rollenbahnen**

**Length Stops / Roller conveyor**

**Butées de longueur / Convoyeurs à rouleaux**

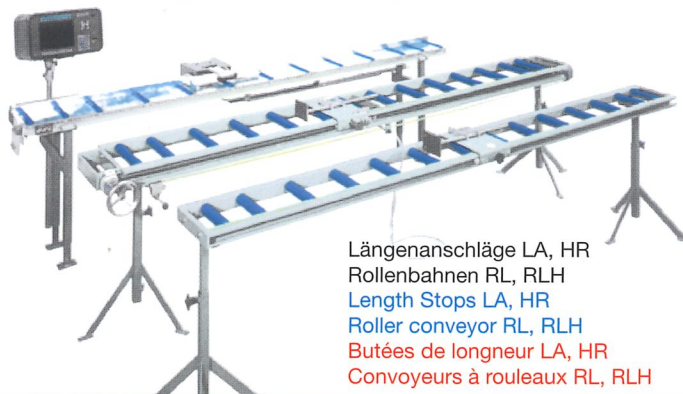

Längenanschläge LA, HR  
Rollenbahnen RL, RLH  
Length Stops LA, HR  
Roller conveyor RL, RLH  
Butées de longueur LA, HR  
Convoyeurs à rouleaux RL, RLH

**Beschlagsmontage**

**Fitting Stations**

**Montage Ferrures**

**FA 1000**



Flügelanschlagplatz FA 1000  
Fitting and Mounting Station FA 1000  
Table de montage ferrures FA 1000

**FA 2000**

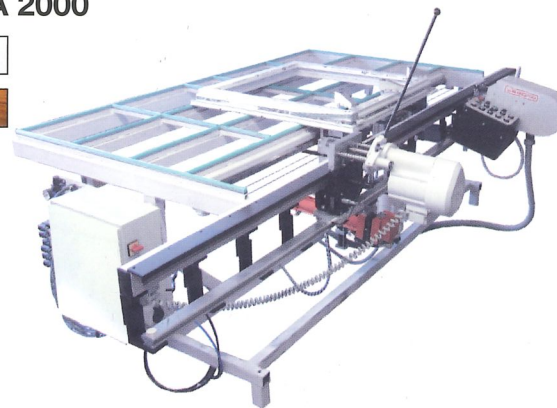

Flügelanschlagplatz FA 2000  
Fitting and Mounting Station FA 2000  
Table de montage ferrures FA 2000

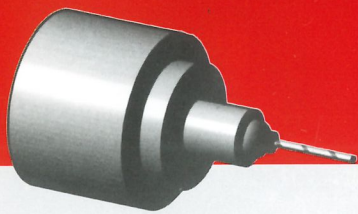

**Bohren / Fräsen / Verbinden / Schrauben / Biegen**  
**Drilling / Routing / Crimping / Screwing / Bending**  
**Percer / Fraiser / Assembler / Visser / Cintrer**

**KF 225**



Kopierfräse KF 225  
 Copy Router KF 225  
 Fraiseuse à Copier KF 225

**AKF 125**



Ausklankfräsen AKF 125, AKF 126, AK 255, AK 255/3, AK 500  
 End Millers AKF 125, AKF 126, AK 255, AK 255/3, AK 500  
 Fraiseuses en bout AKF 125, AKF 126, AK 255, AK 255/3, AK 500

**SE1S/SE3S**



Schraubanlagen SE1S/SE3S  
 Drilling Machines SE1S/SE3S  
 Unités de vissage SE1S/SE3S

**KF 130**



Kopierfräse KF 130  
 Copy Router KF 130  
 Fraiseuse à Copier KF 130

**KF 228**



Kopierfräse KF 228  
 Copy Router KF 228  
 Fraiseuse à Copier KF 228

**KF 227**



Kopierfräse KF 227  
 Copy Router KF 227  
 Fraiseuse à Copier KF 227

**SK 7**



Bohr- & Fräsmaschine SK 7  
 Handl Prep Machine SK 7  
 Perceuse-Fraiseuse SK 7

**WSK 8-3**



Wasserschutzfräse WSK 8-3  
 Water Slot Router WSK 8-3  
 Fraiseuse à écoulement d'eau WSK 8-3

**TSA 450**



Taktsägeautomat TSA 450  
 Automatic Feed and Cut off Saw TSA 450  
 Tronçonneuse automatique TSA 450

**WS 211**



Wasserschutzfräse WS 211  
 Water Slot Router WS 211  
 Fraiseuse à écoulement d'eau WS 211

**EV 175**



Eckverbindungsmaschine EV 175  
 Corner Crimping Machine EV 175  
 Sertisseuse EV 175

**BA 400**



Universal Rundbiegemaschine BA 400  
 Universal bending Machine BA 400  
 Cintreuse universelle BA 400

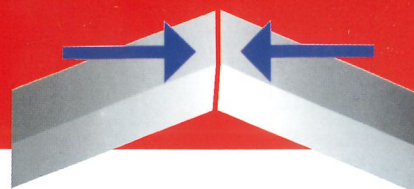

**WSA 1**



Einkopfschweißmaschinen  
 WSA 1E, WSA 1, WSA 1K, WSA 1UNI  
 Single-Head Welding Machines  
 Soudeuses à une tête

**WSA 2**



Zweikopfschweißmaschinen WSA 2, WSA 2UNI  
 Double-Head Welding Machine WSA 2, WSA 2UNI  
 Soudeuses à deux têtes WSA 2, WSA 2UNI

**WSA 4V**

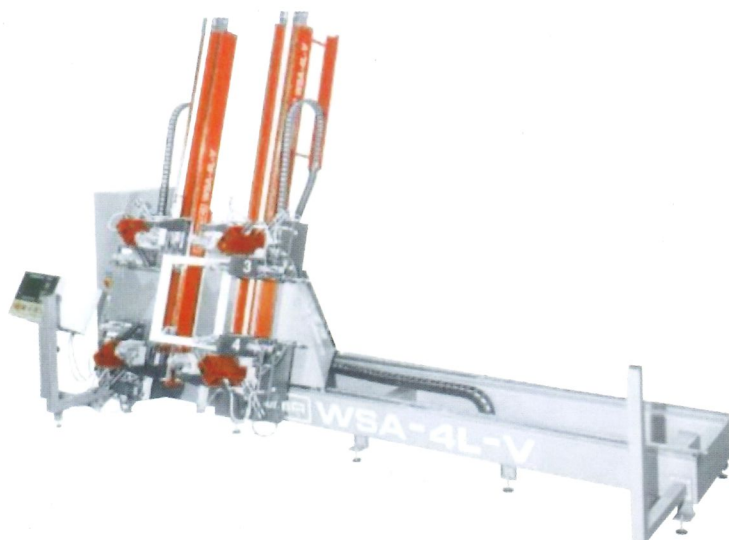

Vertikale Vierkopf-Schweißmaschine WSA 4V  
 Vertical Four-Head Welding Machine WSA 4V  
 Soudeuses à quatre têtes verticale WSA 4V

**WPA 1  
 WPA 4**



Eckenputzautomaten  
 WPA 1, WPA 1B, WPA 4  
 Corner Cleaning Machines  
 Ébavureuses

**K 111**



Kämpfer-Abstechmaschine K 111  
 Transon Groover  
 Ébavureuse (soudure en V) des impostes

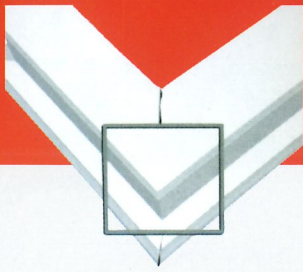

**Horizontale Schweiß- Putz- Linie**  
**Horizontal Welding / Cleaning Line**  
**Ligne de soudage - ébavurage horizontale**



Eckenputzautomat WPA-CNC-2 mit frequenzgesteuerter Wendestation im Verbund mit Schweißautomat WSA 4H  
 Corner Cleaner WPA-CNC-2 with frequency controlled turning station, connected to the Welding Automat WSA 4H  
 Ébavureuse WPA-CNC-2 avec table de retournement, et soudeuse WSA 4H

Horizontal Vierkopf-Schweißmaschine WSA 4H  
 Horizontal Four-Head Welding Machine WSA 4H  
 Soudeuse à quatre têtes horizontable WSA 4H

**WSA 3UNI**



**WSA 4UNI**



Mehrkopf-Schweißmaschinen WSA 3UNI, WSA 4UNI  
 Multit-Head Welding Machines WSA 3UNI, WSA 4UNI  
 Soudeuses à trois et quatre têtes WSA 3UNI, WSA 4UNI

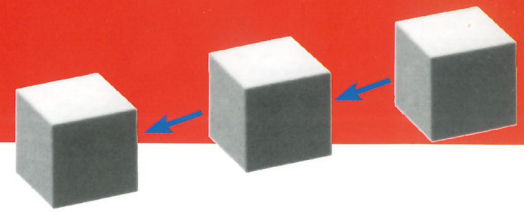

### Super Cut 1100

Ohne mechanisches Umrsten fr alle  
 Profilsysteme einsetzbar  
 Without any additional mechanical set-up's  
 suitable for profile systems  
 Sans rglage mcanique utile pour tous  
 les systmes de profils

Vorteile in einer Anlage vereint SC 1100  
 Advantages integrated in one unit SC 1100  
 Avantages intgrs en une seule unit SC 1100

Doppelbahnausfhrung  
 In double track design  
 Opration en double voies



Im Takt: Sgen + Bearbeiten am Beispiel Super Center 1000  
 In Cycle: Cutting + Processing for example Cutting Center 1000  
 En cadence: Scier + usiner par exemple Super Center 1000

Sgen 45°/90°/45°-Schnitte, Klinkenschnitte einseitig, beidseitig, Kmpferspitzenschnitte  
 Cutting 45°/90°/45°-cutting, V-cut one side, V-Cut both side, transon arrow head cut  
 Scier 45°/90°/45°-coupes, Coupe V sur 1 ct, coupe sur 2 cts, coupe des traverses en pointes

Bearbeiten Armierung, Ecklagerbohrungen, Scherenlagerbohrungen, Dbellochbohrungen, Kmpferlochbohrungen, Olivenbohrungen  
 Processing reinforcements, Corner hinge bores, hinges storage bores, anchor hole bores, transon connection bores, handle hole bores (espagnolettes)  
 Travaux de renforcement, Trous pivot d'angle, perage OB, trous de chevilles, trous de traverses, trous de crmones

Bearbeiten Kunststoff, Wasserschlitzfrsung, Belftungsbohrungen, Schlieteilmarkierung, Eckbandbohrungen, Schlokastenfrsung, Dichtungsnutfrsung  
 Processing in PVC, Water drainage slots, ventilation bores, closer plate markings, corner hinge bores, gear box routing, gasket hole routing  
 Usinage dans PVC, Fraisage coulement d'eau, trous d'aration, marquage de gaches, perage des pivots d'angle, fraisage boitier crmones, fraisage rainures de joints

	Einzelstahl / Single Cut (E) Doppelstahl / double Cut (D) Double-barres (D)	Sgen Saw Scier	Bearbeitung im PC Machining in PC Usinage de PC	Bearbeitung mit Armierung Machining in Reinforcing Usinage avec le reinfort	Einheiten pro 8 Std. (ca.) Units in 8 hours (approx) Menuiserie en 8H00 de travail
<b>Super center 1000</b>	<b>E</b>	✓	-	-	<b>200</b>
<b>Super center 1100</b>	<b>E</b>	✓	✓	✓	<b>120</b>
<b>Super center 3000</b>	<b>D</b>	✓	✓	-	<b>240</b>
Stabbearbeitungszentrum Processing station Centre d'usinage DGS BAZ	<b>D</b>	-	✓	✓	<b>120</b> Basierend fr Deutsche Fenster Based on German windows Bas sur fentres allemandes

### Super center 1000



Profilunabhngiges, vollautomatisches Sgezentrum Super Center 1000  
 Profil independent, fully automatic Cutting Center 1000  
 Automate de dbit multi-gammes Super Center 1000

**WEGOMA GERMANY**  
**WEGOMA Fensterbau-Maschinen GmbH**  
Kaulbachstr. 48 · D-75175 Pforzheim/Germany  
Telefon +49-7231-77 884 20  
Telefax +49-7231-77 884 29  
e-mail: info@wegoma-d.de

WEGOMA Germany/Nord  
Untere Straße 27 · D-42499 Hückeswagen / Germany  
Telefon +49-2192-85 99 22  
Telefax +49-2192-85 99 23  
e-mail: info@wegoma-d.de

**WEGOMA CHINA**  
NanYuan Lu Kou, South Taiping Road  
Taicang, 215400, P.R. China  
Phone +86-512-5353 7598  
Fax +86-512-5353 3845  
e-mail: wegomachina@yahoo.com.cn

**WEGOMA FRANCE**  
26, Rue de l'Église · F-67390 OHNENHEIM/ France  
Tel. +33-3-88920008 · Mobil +33-616 580 560  
e-mail: wegoma@neuf.fr

**WEGOMA (GB) Ltd.**  
Unit 10 Dunscair Industrial Estate  
Blackburn Road · GB-Bolton, Lancashire BL7 9PQ  
Phone +44-1204-303-777  
Fax +44-1204-303-888  
e-mail: wegoma@btconnect.com

**WEGOMA S.R.L. ITALY**  
Via Del Pino, 7 · I-47822 Santarcangelo di R./Italia  
Phone +39-0541-620 944  
Fax +39-0541-620 956  
e-mail: wegoma@libero.it

**WEGOMA POLAND**  
WEGOMA Technika Okiena  
Ul. Armii Krajowej 46 · PL-64-000 Koscian/Polska  
Phone +48-65 512 31 34  
Fax +48-65 512 53 62  
e-mail: biuro@wegoma.com.pl

**WEGOMA UKRAINE**  
UA-01004 Kiev/Ukraine  
Phone/Fax +380-44-287 35 64  
e-mail: wegoma@gmail.com

**WEGOMA ROMANIA**  
SOS. Alexandriei Nr 480  
Bragadiru · Judet ILfov · Bucuresti  
Phone/Fax +40-21-4480919  
Mobile 0720 946240  
e-mail: masini-termopane@wegoma.ro

**WEGOMA SOUTH AMERICA**  
Parana 834 · (1636) La Lucila  
Prov. Buenos Aires/Argentina  
Phone/Fax +54-11-4790 6150  
e-mail: wegomagmbh@yahoo.com.ar

**WEGOMA IRAN**  
Azadi Ave. - Metro Station - Heidari  
Alle Nr. 124 - Teheran 14566-83373  
Phone/Fax +98-21-605 3280  
Mobile +98-(0)912 286 0063  
e-mail: s.adibi@wegoma-d.de

**WEGOMA MIDDLE EAST FZC**  
Sharjah SAIF Zone - UAE - POBox 120847  
Phone + 97 16 57 48 011  
Fax + 97 16 57 48 018  
e-mail: firasdema@yahoo.com

**WEGOMA INDIA**  
C-1 / 296, G.I.D.C.,  
POR ROAD N° : "H"  
Por Ramangamdi,  
Vadodara, Gujarat.  
INDIA - 391243  
Phone + 91-265-2831 808  
Mobile + 91-932 7471921 / 942 6712030  
Fax + 91-265-2831 808  
e-mail: wegomaindia@gmail.com

**WEGOMA BALTICUM**  
Kirtimu 59a · LT 02244 Vilnius  
Litauen (Lithuania)  
Phone + 370 526 03200  
Fax + 370 526 85482  
e-mail: wegoma@wegoma.lt

### **Anspruchsvolle Technik für den Fensterbau**

Von der kompakten Einzelmaschine über die computergesteuerte Fertigungsstraße bis hin zur ganzheitlichen Werkskonzeption.....

WEGOMA bietet alles, was der moderne Fensterbau braucht. Unsere weltweit anerkannte Stärke ist die Realisierung kundenspezifischer Lösungen. Ob Handwerksbetrieb oder computergesteuertes Großfertigungsunternehmen- wir entwickeln und produzieren für jeden Kundenbedarf die optimale Betriebseinrichtung.

Unsere Fachberater als Ihre Partner analysieren Ihre Bedürfnisse, erstellen Wirtschaftlichkeitsberechnungen und unterbreiten maßgeschneiderte Lösungsvorschläge. Umfassendes Know-how, Ausrichtung auf die Probleme des Fensterherstellers, ständige, zukunftsorientierte Entwicklungsarbeit und profunde Kenntnisse der internationalen Märkte sind die stabilen Grundlagen unserer erfolgreichen Unternehmenspolitik.

Rationelle und wirtschaftliche Fertigungsprozesse, computergesteuerte Produktionsplanung und eine leistungsfähige Materialwirtschaft sichern die zuverlässige Auftragsabwicklung. Für die Qualität unserer Produkte steht die anwendungsgerechte Planung, die sorgfältige Fertigung und ein reibungslos funktionierender Kundendienst.

Unser Ziel ist, in allen Bereichen Bestleistungen zu bieten. In der Beratung, in der Projektierung, in der Technik, im Service.

**WEGOMA Fensterbau-Maschinen GmbH**

### **Sophisticated technology for Window Construction**

From a compact single machine to a computer-controlled production line to the overall of a multi-faceted production facility - WEGOMA has everything modern window construction needs.

Our strength to find efficient solutions for specific customers requirements is accepted worldwide. Small work shop or computer controlled mass production- we design and produce the optimized equipment for each individual customer.

Our representatives are your partners to analyse your needs, calculate feasibility studies and offer custom made solutions. Comprehensive know how, focusing on the problems in the window manufacturing process, continued development of future technologies and profound knowledge of international markets are the solid ground of the company's policy.

Efficient manufacturing methods, CAD/CAM production control and quick logistics guarantee the reliable processing of your orders.

The quality of your products is based on practical engineering, careful production and reliable after sales service. Our target is to be the best in all fields: Planning, consulting, engineering and service.

**WEGOMA Fensterbau-Maschinen GmbH**

### **Technique de pointe pour la fabrication de fenêtres**

Depuis la machine spécialisée compacte, en passant par la ligne de production pilotée par ordinateur, jusqu'au concept d'équipement clés-en-main d'une unité de production - WEGOMA vous offre toute une gamme de solutions professionnelles et modernes.

L'un de nos atouts mondialement reconnu consiste à réaliser des solutions spécifiques sur mesures pour nos clients. Qu'il s'agisse d'une structure artisanale ou d'un gros constructeur, équipé d'un système de pilotage sophistiqué, les équipements que nous développons et que nous produisons répondent de façon optimale aux besoins de la clientèle.

En partenariat avec nous, nos conseillers spécialisés analysent vos besoins, établissent des analyses de rentabilité et vous proposent des solutions sur mesure. La réussite de notre politique commerciale repose sur : un savoir-faire étendu, une écoute des problèmes rencontrés par les professionnels de notre branche, un travail de recherche et de développement résolument tourné vers une technologie de pointe et notre connaissance approfondie des marchés internationaux.

La fiabilité que caractérise le traitement de nos commandes reposent sur: la rationalisation et la rentabilisation de nos processus de fabrication, une politique d'approvisionnement performante et notre système de planification de la production assisté par ordinateur.

La qualité de nos produits est assurée par une conception en fonction des besoins de l'utilisateur, par une production soignée et par un Service Après-Vente très efficace. Notre but consiste à vous offrir des performances optimales sur tous les plans: conseil, conception, technique et services.

**WEGOMA Fensterbau-Maschinen GmbH**