

PRO VER K SMART

NC PROCESSING CENTRE



 **BIESSE**

YEARS

 **BIESSEGROUP**

POWERFUL AND COMPACT



THE MARKET DEMANDS

a change in manufacturing processes, enabling companies to **accept the largest possible number of orders**. This is coupled with the need to maintain high quality standards and customisation of products with **quick and defined delivery times**, as well as responding to the needs of highly creative designers.

BIESSE RESPONDS

with **technological solutions** that enhance and support technical expertise as well as process and material knowledge. **Rover K Smart** is a numerical control machining centre for artisan and small to medium sized businesses looking for simple solutions at affordable prices.



ROVER K SMART

- ✔ FOR MACHINING PANELS AND SOLID WOOD PIECES WITH A SINGLE, INNOVATIVE MACHINE
- ✔ EASY TOOLING AND OPTIMAL PANEL HOLD
- ✔ PANEL AND WORK AREA CLEANING
- ✔ MAXIMUM OPERATOR SAFETY
- ✔ CUTTING-EDGE TECHNOLOGY IS RENDERED ACCESSIBLE AND INTUITIVE.

FOR MACHINING PANELS AND SOLID WOOD PIECES WITH A SINGLE, INNOVATIVE MACHINE

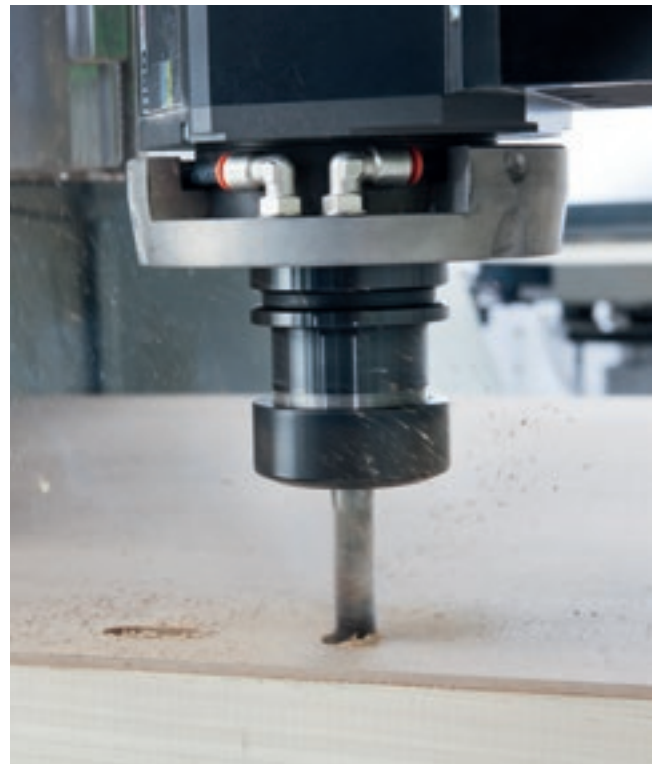

The Rover K Smart is equipped with 3 or 4 independent interpolating axes, and can be fitted with aggregates capable of handling any type of machining operation, both on panels and on solid wood workpieces.



The components of Rover K Smart configurations are the same as those used across Biesse's high-end solutions. The electro-spindle, boring head and aggregates are designed and manufactured for Biesse by HSD, the global leader in this sector.

**C AXIS TORQUE:
QUICKER, MORE
PRECISE, MORE RIGID.**

EASY TOOLING AND OPTIMAL PANEL HOLD

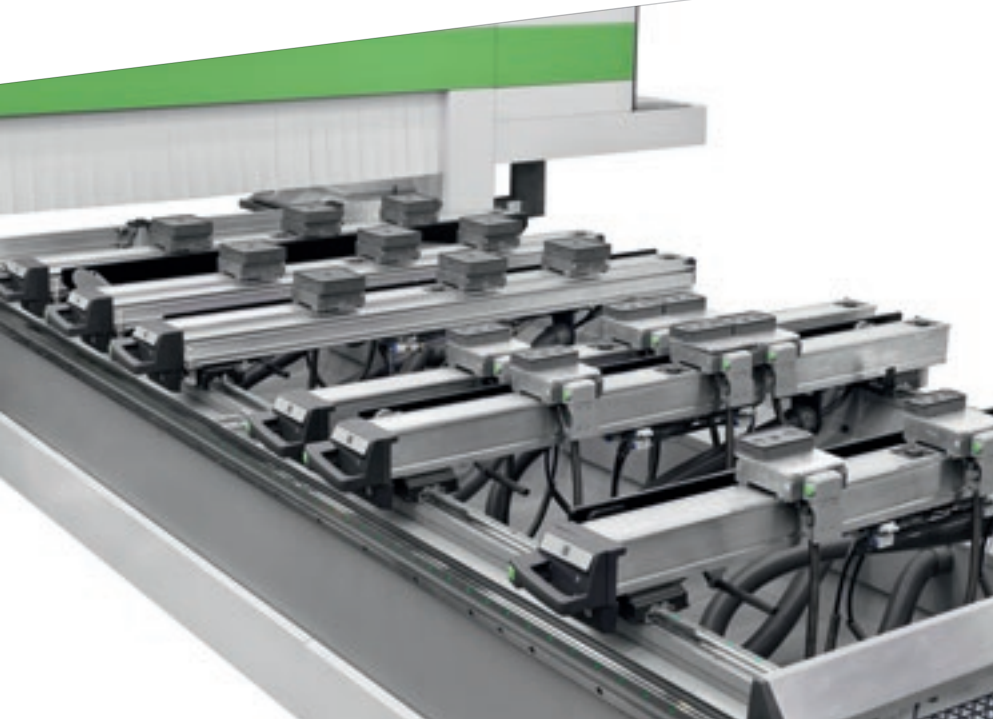

The **Biesse work table** guarantees optimum hold on the workpiece as well as quick tooling.



The innovative **ATS work table** boasts a universal design for superb flexibility and easy configuration.



The quick-coupling system ensures fast and easy replacement of the vacuum modules and the Uniclamps, used to lock narrow and particularly thick pieces in position.



Uniclamp clamps with pneumatic system.



Different references for the machining of multiple components.



The **Pick Up** station supports automatic tool-holder rack tooling.



Thanks to the **16 position tool-holder rack**, tools and aggregates are always available, without the need for operator intervention when moving from one machining process to the next.

SMART LINE

TECHNOLOGY TO NOT MISS OUT ON

High-level technical solutions offering superb results with maximum ease and user safety.

The Smart range for Rover has been created to meet the needs of customers looking for high performance with a limited investment. With high-level, quality components and prismatic linear guides, the work surfaces on these machines can be configured with a variety of working units and are the ideal fit for manufacturers requiring a Y 1500 mm working field and powerful 13 kW electrospindle. These features make Rover Smart machines some of the most compelling and unique solutions in their category, guaranteeing reliability and safety, with CE compliance as standard. Rover K Smart is a competitive solution for machining large panels.

over K Smart

LONG TERM QUALITY AND RELIABILITY

The double X-axis motorisation supports high speeds and accelerations whilst ensuring high quality finish and precision.

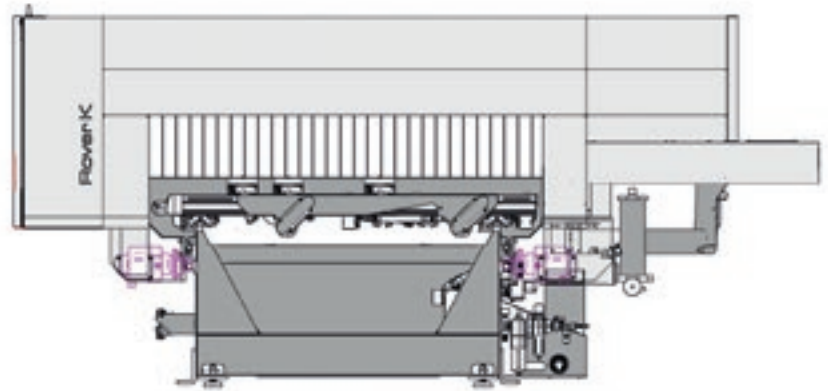

The Gantry structure has been designed to improve the precision and reliability of machining operations. Rigidity and lack of vibration ensures consistent and reliable quality of machined panels.

OPTIMAL PANEL AND WORK AREA CLEANING

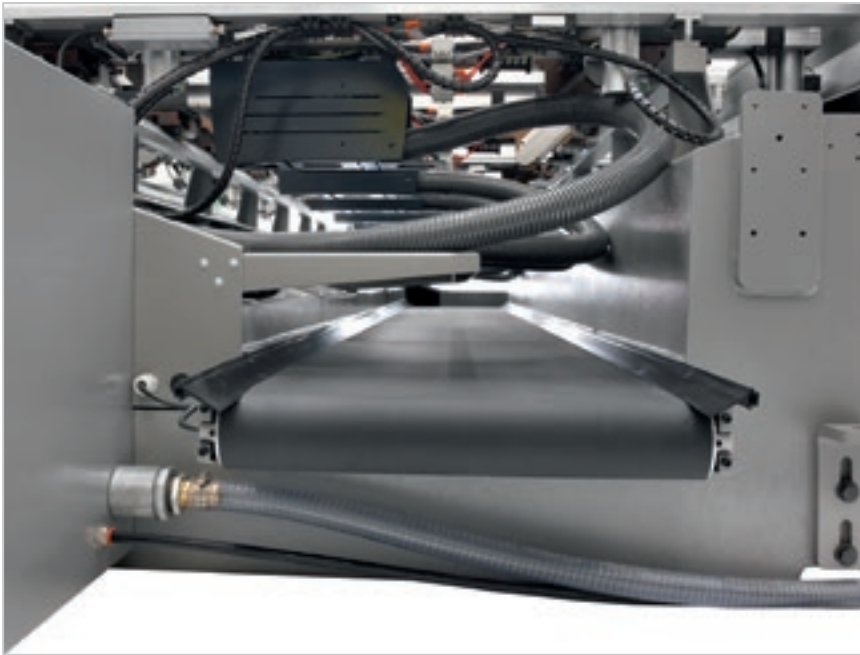

Motorised conveyor belt for the removal of chips and waste.



Adjustable suction hood with 6 settings.

MAXIMUM OPERATOR SAFETY

The fully-enclosed working units with perspex window ensures total safety and maximum visibility.



Pressure-sensitive floor mats for active safety: the machine continues to work consistently at maximum speed, even when the operator is present.





PC with Windows real-time operating system and bSolid software interface, including anti-collision system.



Remote control panel for direct and immediate operator control.



LED bar with 5 colours, indicating the machine status in real time.

IDENTITY

PRACTICAL DESIGN

An innovative yet simple design is the hallmark of Biesse's distinctive identity.

The transparent polycarbonate reinforced protection door is designed to guarantee maximum visibility for the operator. Fitted with 5-colour LEDs indicating machine status, it ensures that processing phases can be easily and safely monitored.

ROVER

THE MOST ADVANCED TECHNOLOGY CLOSE AT HAND



BPAD

Wi-Fi control console for performing the key functions required during the preparation of the working area and the tooling of the working units and tool holder warehouses.

The bPad is a valuable tool for supporting teleservicing, courtesy of the camera and bar code reader functions.



BTOUCH

The new 21.5" touch screen which enables you to carry out all of the functions previously performed using the mouse and the keyboard, enhancing the direct interaction between the user and the device. Perfectly integrated with the bSuite 3.0 interface (and with later versions) and optimised for touch, this solution is incredibly simple, and makes the best possible use of the Biesse software functions installed on the machine.

BPAD AND BTOUCH ARE AN OPTIONAL FEATURE WHICH CAN ALSO BE BOUGHT AFTER PURCHASING THE MACHINE, IN ORDER TO IMPROVE THE FUNCTIONALITY AND APPLICATION OF THE TECHNOLOGY AVAILABLE.

INDUSTRY 4.0 READY



Industry 4.0 is the new industry frontier, based on digital technologies and on machines that speak to companies. The products driving this revolution can communicate and interact independently within production processes, which in turn are connected via intelligent networks.



Biesse is dedicated to transforming the factories owned by our customers into real-time factories that are ready to provide digital manufacturing opportunities. Intelligent machines and software become indispensable tools that facilitate the daily work of those who machine wood and other materials on a daily basis.

INDUSTRY 4.0 READY

CONFIGURATION

Powerful and compact, for superb performance both on panels and on solid wood.

Complete and compact working unit configuration, capable of handling any machining operation with the smallest possible footprint.

13.2 kW electrospindle.
BH17L boring head.
1 or 2 outlet horizontal milling units.

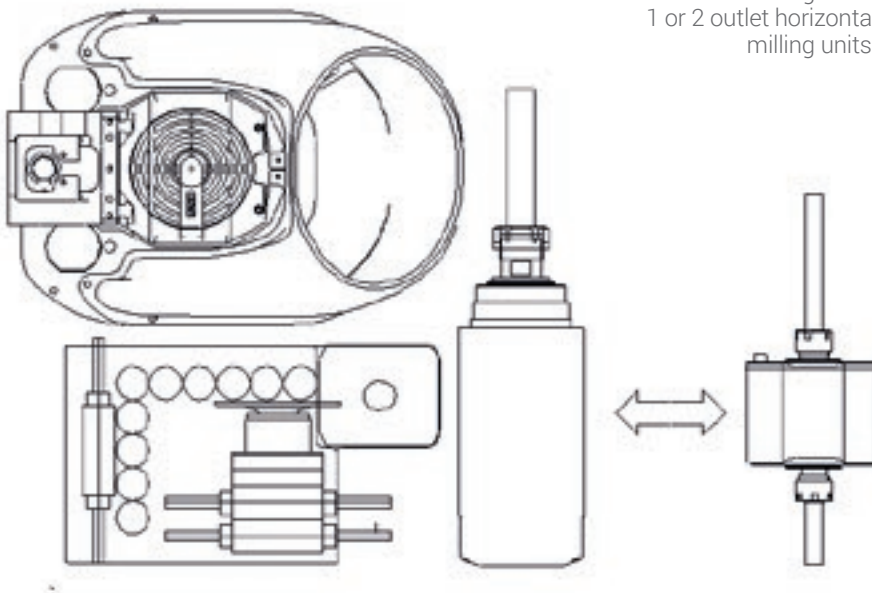

WORKING FIELDS

ROVER K SMART 1532

X	mm/inch	3260/128,3
Y	mm/inch	1560/61,4
Z	mm/inch	165/6,5

The technical specifications and drawings are non-binding. Some photos may show machines equipped with optional features. Biesse Spa reserves the right to carry out modifications without prior notice.

A weighted sound pressure level (LpA) during machining for operator workstation on vane-pump machine LpA=79dB(A) Lwa=96dB(A) A-weighted sound-pressure level (LpA) for operator workstation and sound power level (LwA) during machining on cam-pump machine Lwa=83dB(A) Lwa=100dB(A) K measurement uncertainty dB(A) 4.

The measurement was carried out in compliance with UNI EN 848-3:2007, UNI EN ISO 3746: 2009 (sound power) and UNI EN ISO 11202: 2009 (sound pressure levels at workstation) during panel machining. The noise levels shown are emission levels and do not necessarily correspond to safe operation levels. Despite the fact that there is a relationship between emission and exposure levels, this may not be used in a reliable manner to establish whether further measures need to be taken. The factors determining the exposure level for the workforce include length of exposure, work environment characteristics, other sources of dust and noise, etc. i.e. the number of other adjoining machines and processes. At any rate, the above information will enable the operator to better evaluate dangers and risks.

TECHNICAL DATA

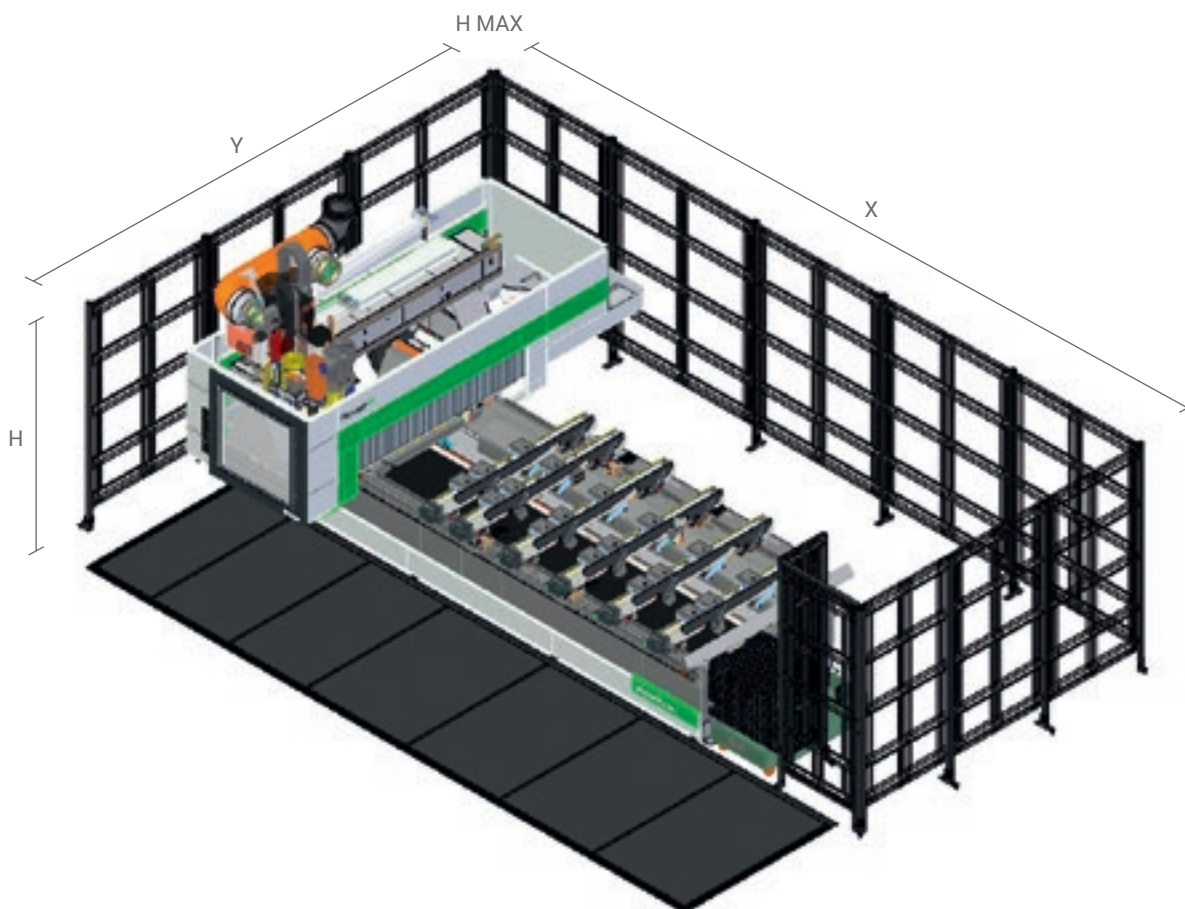

ROVER K SMART 1532

CE Mats

X	mm/inch	6745 / 265,6
Y	mm/inch	4517 / 177,8
H	mm/inch	2000 / 78,7
H MAX	mm/inch	2400 / 94,5
X/Y/Z axis speed	m/min ft/min	85 / 60 / 20 278,8/196,8/65,6
Vector speed	m/min ft/min	104 341,2

HIGH-TECH BECOMES ACCESSIBLE AND INTUITIVE

BSOLID IS A 3D CAD CAM SOFTWARE PROGRAM THAT SUPPORTS THE PERFORMANCE OF ANY MACHINING OPERATION THANKS TO VERTICAL MODULES DESIGNED FOR SPECIFIC MANUFACTURING PROCESSES.

- Planning in just a few clicks, with endless possibilities.
- Simulating machining operations to visualise the piece ahead of manufacturing and have some guidance for the planning phase.
- Virtual prototyping of the piece to avoid collisions and ensure optimal machine equipment.





IDEAS TAKE FORM AND SHAPE

BCABINET IS THE BSUITE PLUGIN FOR FURNITURE DESIGN. IT ALLOWS USERS TO DEVELOP DESIGNS FOR A GIVEN SPACE, AND TO QUICKLY IDENTIFY THE INDIVIDUAL ELEMENTS THAT MAKE IT UP.

- With the new plugin, it is easy to draw both individual items of furniture and complete furnishings for a range of spaces.
- Offering optimal integration with bSuite, users can move from design to manufacturing in just a few clicks.
- Total control and maximum optimisation of the furniture design and creation process, to achieve the highest levels of efficiency.

BCABINET



SOPHIA

GREATER VALUE FROM MACHINES



SOPHIA is the IoT platform created by Biesse in collaboration with Accenture which enables its customers to access a wide range of services to streamline and rationalise their work management processes.

It allows alerts and indicators to be sent to the customer in real time, in relation to production, the machines used and the type of process carried out. These are detailed instructions for more efficient use of the machine.

□ **10% CUT IN COSTS**

□ **50% REDUCTION
IN MACHINE DOWNTIME**

□ **10% INCREASE
IN PRODUCTIVITY**

□ **80% REDUCTION IN PROBLEM
DIAGNOSTICS TIME**

**SOPHIA TAKES THE INTERACTION BETWEEN
CUSTOMER AND SERVICE TO A HIGHER LEVEL.**

iOT
SOPHIA

IoT - SOPHIA provides a comprehensive overview of the specific machine performance features, with remote diagnostics, machine stoppage analysis and fault prevention. The service includes a continuous connection with the control centre, the option of calling for assistance from within the customer app (such calls are managed as priorities), and an inspection visit for diagnostic and performance testing within the warranty period. Through SOPHIA, the customer receives priority technical assistance.

PARTS
SOPHIA

PARTS SOPHIA is the easy new, user-friendly and personalised tool for ordering Biesse spare parts. The portal offers customers, dealers and branches the chance to navigate within a personalised account, consult the constantly updated documentation of the machines purchased, and create a spare parts purchase basket indicating the real time availability in the warehouse and the relative price list. In addition, the progress of the order can be monitored at all times.

 **BIESSE**

in collaboration with  **accenture**

SERV ICE & PARTS

Direct, seamless co-ordination of service requests between Service and Parts. Support for Key Customers by dedicated Biesse personnel, either in-house and/or at the customer's site.

BIESSE SERVICE

- ✔ Machine and system installation and commissioning.
- ✔ Training centre dedicated to Biesse Field engineers, subsidiary and dealer personnel; client training directly at client's site.
- ✔ Overhaul, upgrade, repair and maintenance.
- ✔ Remote troubleshooting and diagnostics.
- ✔ Software upgrade.

500

Biesse Field engineers in Italy and worldwide.

50

Biesse engineers manning a Teleservice Centre.

550

certified Dealer engineers.

120

training courses in a variety of languages every year.

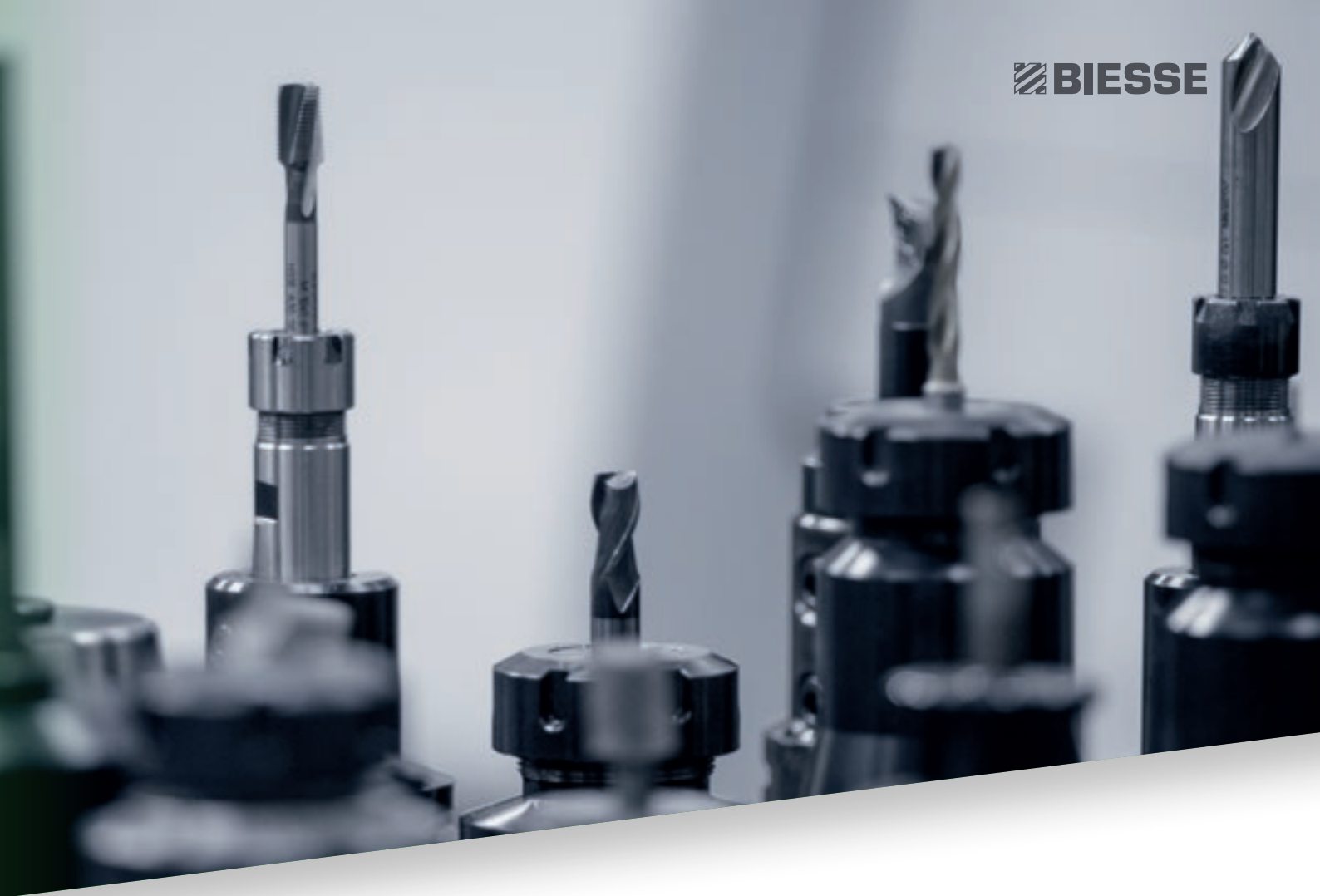
A close-up photograph of several metal drill bits and tool components, arranged in a row. The bits are of different sizes and designs, some with black coatings. The background is a soft, out-of-focus grey.

The Biesse Group promotes, nurtures and develops close and constructive relationships with customers in order to better understand their needs and improve its products and after-sales service through two dedicated areas: Biesse Service and Biesse Parts. With its global network and highly specialized team, it offers technical service and machine/component spares anywhere in the world on-site and 24/7 on-line.

BIESSE PARTS

- ✔ Original Biesse spares and spare kits customized for different machine models.
- ✔ Spare part identification support.
- ✔ Offices of DHL, UPS and GLS logistics partners located within the Biesse spare part warehouse, with multiple daily pick-ups.
- ✔ Order fulfillment time optimized thanks to a global distribution network with de-localized, automated warehouses.

92%
of downtime machine orders fulfilled
within 24 hours.

96%
of orders delivered in full on time.

100
spare part staff in Italy and worldwide.

500
orders processed every day.

MADE WITH BIESSE

BIESSE GROUP TECHNOLOGIES JOIN FORCES WITH LAGO'S INNOVATION AND TOTAL QUALITY MANAGEMENT PROCESSES

In the crowded world of domestic design, Lago takes its place as an emerging brand, thanks to a collection of stimulating products and a corporate philosophy that embraces the interaction between business and art, coupled with on-going research into sustainable development. "We created a number of projects, or rather, concepts - states Daniele Lago - that have shaped Lago as we see it today: we saw design as a cultural vision that applies not only to individual products, but rather to the entire business chain".

"Flexibility is the key word here at Lago" says Carlo Bertacco, Manufacturing

Manager. "We started to introduce the concept of processing only outstanding orders, which enabled us to reduce our footprint and empty the site from the very beginning".

"The machinery that we purchased - states Bertacco - is great, it entailed a limited investment versus the capabilities it offers and is linked to a specific manufacturing approach. What I am talking about is a given manufacturing volume with Lago-standard quality levels and the possibility of customising as late as possible, at the customer's request: in short, the very basic principles of lean manufacturing".

Source:

IDM Industria del Mobile

Lago, our customer since 1999, is one of most prestigious Italian furniture brands in the world.



MACHINING CENTRES RANGE

CNC - ROUTING



Rover Gold G
NCE



Rover Gold
NCE



Rover K Smart



Rover A Smart



Rover A

CNC - ROUTING



Rover A



Rover M5



Rover B



Rover C



Excel

CNC - EDGEBANDING



Rover A Edge



Rover B Edge



Rover C Edge



Rover Edge Line

CNC - NESTING



Rover K FT



Rover S FT



Rover A FT



Rover B FT



Rover C FT

CNC - NESTING



Excel

CNC - WINDOWS AND DOORS



Winline 16

CNC - BORING



Skipper 100



Skipper 130

LIVE THE EXPERIENC

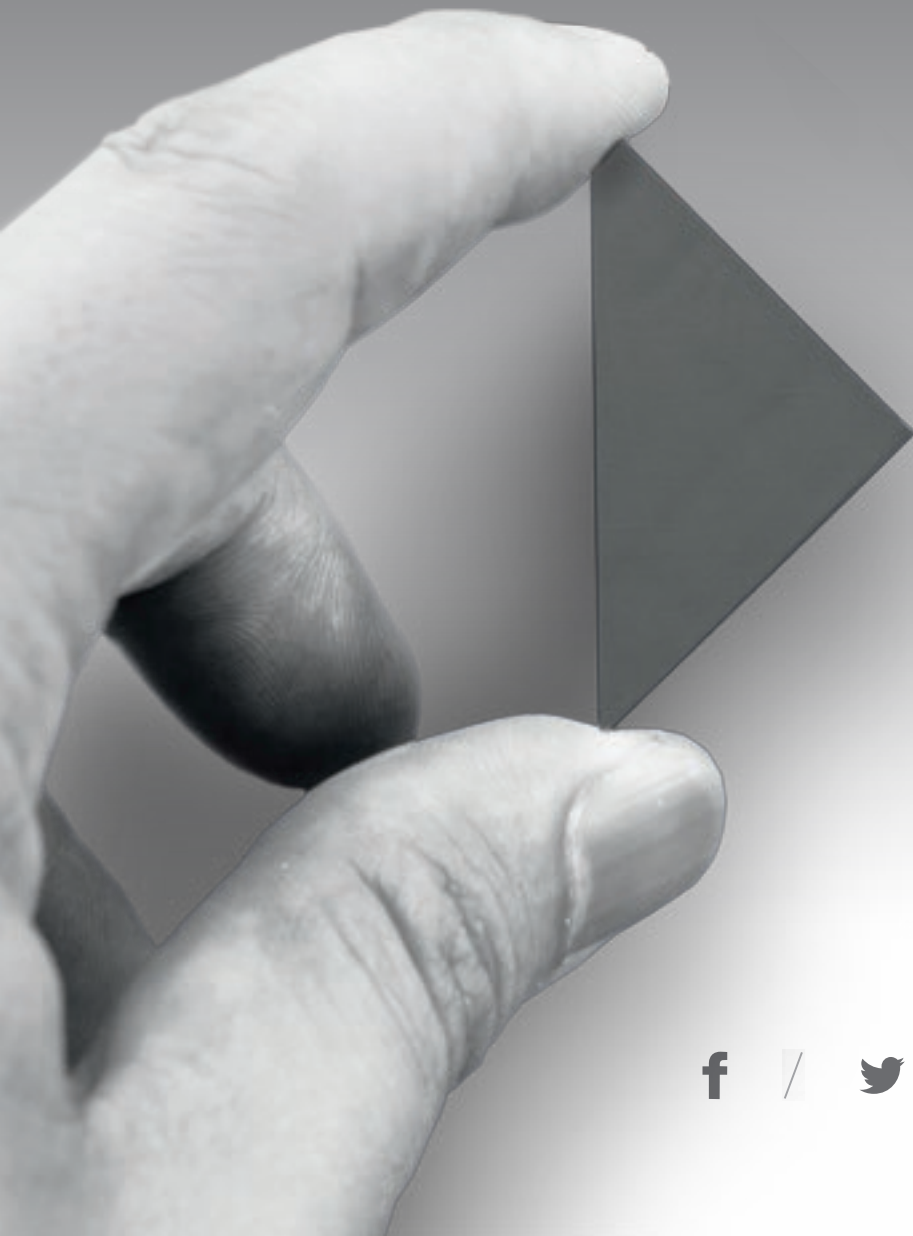

BIESSEGROUP.COM

E



Interconnected technologies and advanced services that maximise efficiency and productivity, generating new skills to serve better our customer.

LIVE THE BIESSE GROUP EXPERIENCE AT OUR CAMPUSES ACROSS THE WORLD.

 **BIESSEGROUP**

