

Perfect edging taken to the point

STREAMER 1053 | 1054



PRODUCTIVITY AND PRECISION





Your compact
entry to
HOLZ-HER edging
technology



STREAMER 1053 | 1054

Superior appearance for all materials

Starting with the state-of-the-art, high gloss edging right up to solid wood edging with cross section of 6 x 65 mm, HOLZ-HER remains unequalled for variety.

HOLZ-HER sets the trends for tomorrow today.



Illustrations may contain
optional features.



- **Processing dimensions just like a big one**
 Compact, simple and powerful up to 6 mm edge thickness and 60 mm of workpiece thickness.
- **Premilling for perfect results**
 Includes two diamond cutters for a perfect preparation of your panel before edgebanding.
- **Clear and powerful**
 Compact control for easiest operation.
- **Perfect finish**
 With two freely selectable post-processing units (radius scraper, surface glue scraper, buffing unit).
- **Always a good connection**
 Highly flexible adhesive application with the classical HOLZ-HER nozzle system.
- **For a water-resistant connection**
 Process PUR glue as easy as EVA glue.
- **Multi-function cutter unit**
 Including diamond tipped cutter.

HOLZ-HER NOZZLE SYSTEM

Hybrid technology – two perfectly combined systems

The edgebander is decisive for furniture with a high quality appearance. You can also profit from 45 years of HOLZ-HER technological leadership in edgebanding.

- Change over from colored to neutral glue at the flick of the wrist.
- Change over from EVA to PUR glue is also possible within the shortest time.
- And the entire system can also be completely cleaned in just minutes.



Unchallenged fast heat-up time only 3 minutes



TECHNICAL DATA

Product brochures and many videos are available at www.holzher.com

Machine	STREAMER 1053	STREAMER 1054
Control	Compact control – rotating and swiveling control panel	Compact control – rotating and swiveling control panel
Workpiece support		
Premilling	x	2 cutter motors incl. 2 diamond cutters, working height 45 mm
Edge feeder	For coils and strips with single infeed	For coils and strips with single infeed
Glue application	Classical HOLZ-HER nozzle system (one glue cartridge) for EVA and PUR glue	Classical HOLZ-HER nozzle system (one glue cartridge) for EVA and PUR glue
Pressure unit	3 pressure rollers, first roller with motor drive	3 pressure rollers, first roller with motor drive
End trimming	1 x 0,22 kW, 200 Hz, 9000 min ⁻¹ , with manual adjustment for chamfering (0/10°)	1 x 0,22 kW, 200 Hz, 9000 min ⁻¹ , with manual adjustment for chamfering (0/10°)
Cutting	Multifunctional flush trimming, radius and radius outlet, incl. diamond cutters	Multifunctional flush trimming, radius and radius outlet, incl. diamond cutters
Scraper		
Glue scraper		
Buffing		

Options
Extendible up to 600 mm
2 premilling cutters with working height 60 mm
Edge magazine with edge separation for strips
Tracing nozzle
Pneumatic pressure unit, plunge controlled
End trimming unit with two motors pneumatic tiltable, working height 60 mm
Smoothing of radii and chamfer on plastic edges
Plunge controlled at top and bottom
Buffing unit

	STREAMER 1053	STREAMER 1054
Machine dimensions		
Overall length (mm)	3917	3917
Weight (kg)	930	1055
Feed speed		
Feed speed (m/min)	10	10
Working dimensions		
Workpiece thickness (mm)	6–45 (60)	6–45 (60)
Edge thickness (mm)	0,4–3 (6)	0,4–3 (6)

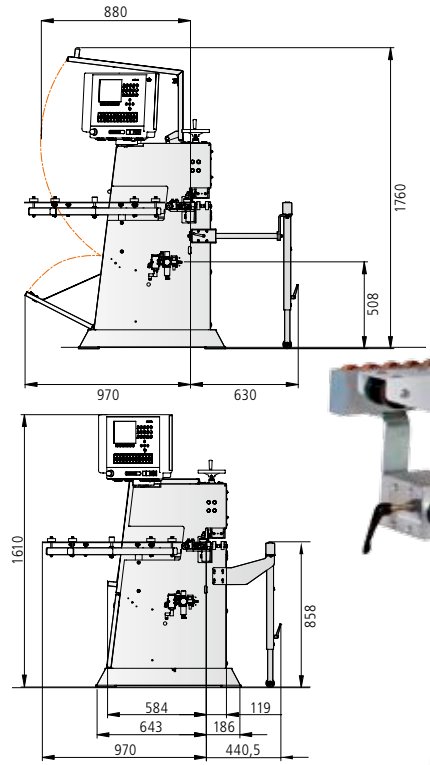

Optional Standard x Not possible Free space

The technical data specified is intended for reference only. HOLZ-HER wood-working machines are subject to constant development and are therefore subject to modification without prior notice. The illustrations are therefore not binding. Some of the machines shown also contain special equipment not included as a standard feature. For clarity, some of the machines are shown without protective hood.

Picture credits: © istock | lisegagne, © fotolia | Alexander Rochau

UK – HOLZ-HER 3143 30 – Printed in Germany/Imprimé en Allemagne
Printed on: 22.06.2012 – First edition: 22.06.2012

Your authorized HOLZ-HER dealer

HOLZ-HER GmbH
Plochinger Straße 65
72622 Nürtingen
Germany
T +49 (0) 70 22 702-0
kontakt@holzher.com
www.holzher.com

